

**MASSACHUSETTS
COMPREHENSIVE
ASSESSMENT
SYSTEM**

*Release of
Spring 2007
MCAS Test Items*

**June 2007
Massachusetts Department of Education**



This document was prepared by the
Massachusetts Department of Education
Dr. David P. Driscoll
Commissioner of Education

The Massachusetts Department of Education, an affirmative action employer, is committed to ensuring that all of its programs and facilities are accessible to all members of the public. We do not discriminate on the basis of age, color, disability, national origin, race, religion, sex or sexual orientation. Inquiries regarding the Department's compliance with Title IX and other civil rights laws may be directed to the Human Resources Director, 350 Main St., Malden, MA 02148 781-338-6105.

© 2007 Massachusetts Department of Education

Permission is hereby granted to copy for non-commercial educational purposes any or all parts of this document, with the exception of English Language Arts passages that are not designated as in the public domain. Permission to copy all other passages must be obtained from the copyright holder. Please credit the "Massachusetts Department of Education."

Massachusetts Department of Education
350 Main Street, Malden, MA 02148-5023
Phone 781-338-3000 TTY: N.E.T. Relay 800-439-2370
www.doe.mass.edu



Table of Contents

Commissioner's Foreword

I. Document Purpose and Structure	1
II. English Language Arts, Reading Comprehension, Grade 3	5
III. English Language Arts, Grade 4	39
A. Composition	40
B. Reading Comprehension	43
IV. English Language Arts, Reading Comprehension, Grade 5	77
V. English Language Arts, Reading Comprehension, Grade 6	109
VI. English Language Arts, Grade 7	139
A. Composition	140
B. Reading Comprehension	142
VII. English Language Arts, Reading Comprehension, Grade 8	169
VIII. English Language Arts, Grade 10	197
A. Composition	198
B. Reading Comprehension	200
IX. Mathematics, Grade 3	227
X. Mathematics, Grade 4	253
XI. Mathematics, Grade 5	277
XII. Mathematics, Grade 6	301
XIII. Mathematics, Grade 7	327
XIV. Mathematics, Grade 8	353
XV. Mathematics, Grade 10	379
XVI. Science and Technology/Engineering, Grade 5	407
XVII. Science and Technology/Engineering, Grade 8	435
XVIII. Biology, High School	457
XIX. Chemistry, High School	485
XX. Introductory Physics, High School	511
XXI. Technology/Engineering, High School	535
XXII. History and Social Science, Grade 5	563
XXIII. History and Social Science, Grade 7	577
XXIV. U.S. History, High School	589

Commissioner's Foreword

Dear Colleagues:

One of the goals of the Department of Education is to help schools acquire the capacity to plan for and meet the accountability requirements of both state and federal law. To assist schools and districts in achieving this goal, the Department regularly releases MCAS test items to provide information regarding the kinds of knowledge and skills that students are expected to demonstrate. In keeping with our past practice of releasing all of the test items on which student results are based, I am pleased to announce that all common items on which student scores are based from most spring 2007 tests are included in *Release of Spring 2007 MCAS Test Items*. Also included is a limited release of items from the grades 5 and 7 History and Social Science tests, and the high school U.S. History test.

Due to its length of approximately 600 pages, this publication is available only on the Department Web site at www.doe.mass.edu/mcas/testitems.html. The test items for individual subjects at each grade level can be easily printed from this site. I encourage local educators to use the relevant sections of this document together with their *Test Item Analysis Report Summaries* and *Test Item Analysis Rosters* as guides for planning changes in curriculum and instruction that may be needed to ensure that schools and districts make regular progress in improving student performance.

Thank you for your support as we work together to strengthen education for our students in Massachusetts.

Sincerely,

David P. Driscoll
Commissioner of Education

I. Document Purpose and Structure

Document Purpose and Structure

Purpose

The purpose of this document is to share with educators and the public all of the test items on which the spring 2007 MCAS student results are based. Local educators will be able to use this information to identify strengths and weaknesses in their curriculum and instruction, and to guide the changes necessary to more effectively meet their students' needs.

This document is also intended to be used by school and district personnel as a companion document to the test item analysis reports. Each school receives in the fall a 2007 *School Test Item Analysis Report Summary* and a *Test Item Analysis Roster* for each content area at each grade level tested (e.g., grade 10 Mathematics). These reports provide data generated from student responses. Each report lists, for the school receiving the report, the names of all enrolled students in the grade covered by the report and shows how each student answered each common item in that report's content area. The report labels each item as multiple-choice, open-response, short-answer, or writing prompt and identifies the item's MCAS reporting category. Item numbers in this document correlate directly to the "Item Numbers" in the test item analysis reports.

Structure

Each subsequent chapter of this document contains information and materials for one MCAS test (one grade level and one content area). For example, chapter II contains information for the grade 3 ELA Reading Comprehension test; chapter XV contains information for the grade 10 Mathematics test. Note that chapters III, VI, and VIII contain information for both the ELA Composition (Part A) and the ELA Reading Comprehension (Part B) tests for the relevant grade.

Beginning with chapter II, each chapter has three main sections. The **first section** introduces the chapter by listing the Massachusetts *Curriculum Framework* content strands assessed by MCAS in that chapter's content area. These content strands are identical to the MCAS reporting categories under which test results are reported to schools and districts. The first section also provides the Web address for the relevant *Framework* and the page numbers on which the learning standards assessed by the test items in the chapter can be found. In addition, there is a brief overview of the test (number of test sessions, types of items, reference materials allowed, and cross-referencing information).

The **second section** contains the common test items used to generate spring 2007 MCAS student results for that chapter's grade level and content area. With the exception of the ELA Composition writing prompt, the test questions in this document are shown in the same order and basic format in which they were presented in the test booklets. The Mathematics reference tools used by students during MCAS Mathematics test sessions (Mathematics Tool Kits for grades 3 and 4; Mathematics Reference Sheets for grades 5, 6, 7, 8, and 10) are inserted immediately following the last question in the second section of each Mathematics chapter. Students in all the tested grades were also provided with plastic rulers. Images of these rulers are not presented in this document. The reference tools used by students during the high school Science and Technology/Engineering tests (Chemistry Formula and Constants Sheet/

Periodic Table of the Elements for the Chemistry test; formula sheets for the Introductory Physics and Technology/Engineering tests) are inserted immediately following the last question in the second section of the associated chapter. A plastic ruler is also provided to students taking the high school Technology/Engineering test.

Due to copyright restrictions, certain English Language Arts reading passages are not available on the Department's Web site. Copyright information for all common reading passages is provided in the document. Note that the Department of Education has obtained permission to post all English Language Arts reading passages that appear on its Web site. While the Department grants permission to use the posted test items for educational purposes, it cannot grant or transfer permission to use the passages that accompany the items. Such permission must be obtained directly from the holder of the copyright. For further information, contact Student Assessment Services at 781-338-3625.

The **final section** of each chapter is a table that cross-references each common item with its MCAS reporting category and with the *Framework* standard it assesses. Correct answers to multiple-choice questions and, for the Mathematics tests, short-answer questions are also listed in the table.

Responses to open-response items and compositions written in response to writing prompts are scored individually. An overview of procedures for scoring these responses and compositions is presented in the MCAS fact sheet, "Scoring Student Answers to Open-Response Questions and Writing Prompts," which is available on the Department's Web site at www.doe.mass.edu/mcas. Scoring procedures will also be explained further in the MCAS document, *Guide to Interpreting the Spring 2007 MCAS Reports for Schools and Districts*, due for release in fall 2007. Similar guides are currently available on the Department's Web site for previous years' MCAS *School Reports* and *District Reports*. Sample student responses and compositions from previous MCAS administrations may also be viewed on the Department's Web site.

Materials presented in this document are **not** formatted **exactly** as they appeared in student test booklets. For example, in order to present items most efficiently in this document, the following modifications have been made:

- Some fonts and/or font sizes may have been changed and/or reduced.
- Some graphics may have been reduced in size from their appearance in student test booklets; however, they maintain the same proportions in each case.
- For grades 7 and 10, the English Language Arts Composition writing prompt is presented on the same page as the make-up writing prompt, and the four lined pages provided for students' initial drafts are omitted.
- All references to page numbers in answer booklets have been deleted from the directions that accompany test items.

A partial release of common items from the grades 5 and 7 History and Social Science tests, and the high school U.S. History test is included in this publication.

II. English Language Arts, Reading Comprehension, Grade 3

Grade 3 English Language Arts Reading Comprehension Test

The spring 2007 grade 3 MCAS English Language Arts Reading Comprehension test was based on learning standards in the two content strands of the Massachusetts *English Language Arts Curriculum Framework* (2001) listed below. Specific learning standards for grade 3 are found in the *Supplement to the Massachusetts English Language Arts Curriculum Framework* (2004). Page numbers for the learning standards appear in parentheses.

- Language (*Framework*, pages 19–26; *Supplement*, pages 6–7)
- Reading and Literature (*Framework*, pages 35–64; *Supplement*, pages 7–9)

The *English Language Arts Curriculum Framework* and *Supplement* are available on the Department Web site at www.doe.mass.edu/frameworks/current.html.

In *Test Item Analysis Reports* and on the Subject Area Subscore pages of the *MCAS School Reports* and *District Reports*, ELA Reading Comprehension test results are reported under two MCAS reporting categories: **Language** and **Reading and Literature**, which are identical to the two *Framework* content strands listed above.

Test Sessions and Content Overview

The MCAS grade 3 ELA Reading Comprehension test included three separate test sessions. Each session included selected readings, followed by multiple-choice and open-response questions. Common reading passages and test items are shown on the following pages as they appeared in grade 3 test & answer booklets. Due to copyright restrictions, certain reading passages cannot be released to the public on the Web site. For further information, contact Student Assessment Services at 781-338-3625.

Reference Materials and Tools

The use of bilingual word-to-word dictionaries was allowed for current and former limited English proficient students only, during all three ELA Reading Comprehension test sessions. No other reference materials were allowed during any ELA Reading Comprehension test session.

Cross-Reference Information

The table at the conclusion of this chapter indicates each item’s reporting category and the *Framework* general standard it assesses. The correct answers for multiple-choice questions are also displayed in the table.

English Language Arts

Reading Comprehension

SESSION 1

DIRECTIONS

This session contains one reading selection with eight multiple-choice questions. Mark your answers by filling in the circle next to the best answer.

Laura Ingalls Wilder wrote about living in America in the late 1800s, when much of our country was still wilderness. In this story, Laura is five years old; Pa has gone into town and has not yet returned. Read the story and answer the questions that follow.

from *Little House in the Big Woods*

by Laura Ingalls Wilder

Students read a selection titled *Little House in the Big Woods* and then answered questions 1 through 8 that follow on pages 11 and 12 of this document.

Due to copyright restrictions, the selection cannot be released to the public over the Internet. For more information, see the copyright citation below.

Text copyright 1932, 1960 Little House Heritage Trust. Used by permission of HarperCollins Publishers. Little House® is a registered trademark of HarperCollins Publishers.

Due to copyright restrictions, the selection that appeared on this page cannot be released to the public over the Internet. For more information, see the citation on the previous page.

Due to copyright restrictions, the selection that appeared on this page cannot be released to the public over the Internet. For more information, see the citation on page 7.

Due to copyright restrictions, the selection that appeared on this page cannot be released to the public over the Internet. For more information, see the citation on page 7.

Mark your choices for multiple-choice questions 1 through 8 by filling in the circle next to the best answer.

- 1 Read the sentence from paragraph 5 in the box below.

The woods were dark, but there was a gray light on the snowy path, and in the sky there were a few faint stars.

What is **true** about the sentence?

- (A) It explains the problem in the story.
- (B) It explains the lesson that the story teaches.
- (C) It describes the setting for part of the story.
- (D) It describes the solution to the problem in the story.

- 2 According to paragraph 17, what is the **main** reason the barn door is so solid and heavy?

- (A) to keep the farm animals quiet
- (B) to keep the farm animals safe
- (C) to keep the barn warm
- (D) to keep the barn dry

- 3 According to paragraph 19, why is Ma pleased with Laura?

- (A) Laura went to bed early.
- (B) Laura worried about Sukey.
- (C) Laura obeyed her mother right away.
- (D) Laura carried the lantern while Ma milked.

- 4 In paragraph 20, what makes Ma laugh?

- (A) She is happy to be safe inside.
- (B) She is happy that Pa has come home safely.
- (C) She thinks it is amazing that she hit a bear.
- (D) She thinks it is silly that Laura is so worried.

5 According to the story, why does Ma latch the door before going to bed?

- (A) so nothing can get inside
- (B) so the girls can go to sleep
- (C) to block the sound of the wind
- (D) to keep the wind from blowing the door open

6 In the story, what proves that a bear had been in the yard?

- (A) Pa saw the bear on his way home.
- (B) Sukey and the horses had bear claw marks on them.
- (C) Ma and Laura heard the bear growl as they ran inside.
- (D) There were bear tracks near the barn the next morning.

7 Read paragraph 16 in the box below.

Laura began to cry. She hung on to Ma and sobbed, “Oh, will he eat Sukey?”

Which word in the paragraph helps the reader understand the word *sobbed*?

- (A) began
- (B) cry
- (C) hung
- (D) eat

8 Read the sentence from paragraph 7 in the box below.

It was too early in the spring for Sukey to be let out in the Big Woods to eat grass.

Which sentence uses the word *spring* in the same way as the sentence in the box?

- (A) The cat will spring toward the rabbit.
- (B) The campers drink water from a spring.
- (C) The families plant gardens in the spring.
- (D) The pink flowers will spring from the tiny buds.

English Language Arts

Reading Comprehension

SESSION 2

DIRECTIONS

This session contains three reading selections with sixteen multiple-choice questions and one open-response question. For multiple-choice questions, mark your answers by filling in the circle next to the best answer. For the open-response question, write your answer in the space provided below the question.

In this poem, the poet describes what it is like to gather leaves on a windy day. Read the poem and then answer the questions that follow.

Gathering Leaves

In autumn the falling leaves
Run races on the paths,
Tumble head over heels
And catch against the tufts of grass.

5 I gather them in a heap
With a stiff brush and a rake,
Though they are light as feathers
And do their best to escape.

Then I splash right into the heap
10 And the leaves wash over me
With a long swishing sound
Like a wave of the sea.

—*Stanley Cook*

“Gathering Leaves” by Stanley Cook. Reprinted by permission of Sarah Matthews.

Mark your choices for multiple-choice questions 9 through 12 by filling in the circle next to the best answer.

9 In line 7, what are “light as feathers”?

- (A) tufts
- (B) paths
- (C) leaves
- (D) waves

10 In lines 9–12, what is the speaker doing?

- (A) playing in the ocean
- (B) raking leaves in the yard
- (C) running through the woods
- (D) jumping in a pile of leaves

11 Which of the following lines in the poem rhyme?

- (A) lines 1 and 3
- (B) lines 5 and 8
- (C) lines 6 and 7
- (D) lines 10 and 12

12 Read line 9 from the poem in the box below.

Then I splash right into the heap

In the line, the word *splash* is an example of a

- (A) verb.
- (B) noun.
- (C) contraction.
- (D) compound word.

Pilgrims lived in Massachusetts in colonial times. Read this selection about the eating habits and table manners of the Pilgrims. Then answer the questions that follow.

Don't Throw Your Bones on the Floor

by Lucille Recht Penner

1 Pilgrim parents were strict with their children. Some of the rules sound familiar, like this one (from a book called *The School of Manners*) about speaking with your mouth full:

2 When your meat is in your mouth,
do not drink or speak or laugh—
Dame Courtesy forbids.

3 But Pilgrim manners weren't always the same as ours. In their first years in America, they were often too busy for regular meals. People just helped themselves right out of the cooking pot. They ate standing—in front of the fire, if the day was cold—and then hurried off to work again.

4 When the family did eat together, the dinner table was often just some old boards laid on top of barrels. The cooking pot was placed in the middle, and the family gathered around.

5 Later, when the Pilgrims had more time—and more dishes—food was brought to the table on large, round platters called **chargers**.

6 No one had his or her own plate. Instead, two people would share a **trencher**—a bowl carved or burned out of a block of wood.

7 A mother and father shared a trencher. Children shared, too. The Pilgrims thought that people who had their own trenchers were show-offs.

8 Some poor people didn't have wooden trenchers. Instead, they used pieces of stale bread as plates. They put the food on top. Then, after they had eaten the food, they ate the bread plates!

9 Almost nobody used a fork. . . .

10 They thought forks were silly. Why bother, they said. “Fingers were made before forks.”

11 But everyone needed a spoon, because the Pilgrims ate so many soups and stews. The first spoons made in Plymouth were clamshells attached to sticks.

12 Buffalo horns made good spoons, too. You scooped up the food with the open end. Later, when they had more time, people carved spoons out of wood. Some lucky folks had brought pewter or silver spoons from England.

13 And everyone had his or her own knife. If you were a grown-up, it was okay to stick your knife right into the pot and pull out a piece of food. But children weren’t supposed to take any food for themselves. They were supposed to eat whatever their parents handed to them.

14 It was always fine to eat with your fingers. The only rule was that you were supposed to wash them—or at least wipe them—before you stuck them in the pot.

15 Naturally, this meant that everyone needed a napkin. A big napkin! The Pilgrims threw it over one shoulder or tied it around their necks. It hung down almost to their knees. And your napkin wasn’t just for wiping your hands. You could use it to grab pieces of hot food.

16 Often, a Pilgrim family had only one chair, and the father was the one who sat in it. The other family members sat on stools, sections of tree trunk, or wooden benches without backs.

17 Children sometimes had to stand at the table. In some families, this was because there was nothing for them to sit on. Other families made children stand just because they thought it was good manners. They thought it was rude for a child to sit down when a grown-up was in the room.

18 Sometimes children had to stand at a separate little table. They came to the main table to have their trenchers filled.

. . .

19 Men and boys were allowed to keep their hats on while they were eating. They needed to take them off only to drink a toast.

- 20 A polite person did not scratch at the table. Most people had lice and fleas living in their hair and clothes. But it was good manners to wait until you were done eating to scratch. It wasn't pleasant to see your neighbor mash a flea and then reach into the trencher you were sharing.
- 21 A big bowl of salt was placed in the center of the table. Important guests sat near the father, toward the head of the table—"above the salt." Children and other less important people were near the foot of the table—"below the salt."
- 22 It was very bad manners to dip your food right into the salt bowl. The salt would get sticky. You were supposed to take salt only with a clean knife.
- 23 If you wanted bread, you broke a piece off the loaf with your hands. You could use it to mop up your plate.
- 24 When you were eating meat, what did you do with the bones? Throwing them on the ground was considered poor manners. And you weren't supposed to put them back in the pot. The correct thing was to pile them neatly on the table.

Reprinted with the permission of Simon & Schuster Books for Young Readers, an imprint of Simon & Schuster Children's Publishing Division from *EATING THE PLATES* by Lucille Recht Penner. Copyright © 1991 by Lucille Recht Penner.

Mark your choices for multiple-choice questions 13 through 20 by filling in the circle next to the best answer.

- 13 According to the selection, what was the reason the Pilgrims did **not** have regular meals when they first came to America?

(A) There was not enough food.
(B) They had a lot of work to do.
(C) They were too cold to sit and eat.
(D) Tables had not been invented yet.

- 14 What is the **main** idea in paragraphs 11 and 12?

(A) Buffalo horns made the best spoons.
(B) Spoons were first made from clamshells.
(C) Pewter and silver spoons were very valuable.
(D) Spoons were made from many different materials.

- 15 In the selection, if a Pilgrim family had only one chair, who would sit in it at mealtime?

(A) the father
(B) the mother
(C) the oldest son
(D) the youngest child

- 16 Which of the following sentences **best** describes the main idea of paragraph 20?

(A) Scratching fleas was common.
(B) It was rude to have lice or fleas.
(C) Scratching at the table was bad manners.
(D) It was impolite to share food if you had fleas.

17 According to the selection, who was **most likely** to sit “below the salt”?

- Ⓐ a father
- Ⓑ a mother
- Ⓒ a young child
- Ⓓ a special guest

18 Based on the selection, how did Pilgrims put salt on their food?

- Ⓐ with a knife
- Ⓑ with a salt shaker
- Ⓒ by dipping food into the salt
- Ⓓ by dipping their fingers into the salt

19 According to the selection, which of the following was **most** necessary for eating in colonial days?

- Ⓐ a fork
- Ⓑ a chair
- Ⓒ a barrel
- Ⓓ a spoon

20 According to the selection, what were Pilgrims supposed to do with leftover bones?

- Ⓐ wrap them in a napkin
- Ⓑ stack them on the table
- Ⓒ throw them onto the floor
- Ⓓ put them into the cooking pot

Question 21 is an open-response question.

- Read the question carefully.
- Explain your answer.
- Add supporting details.
- Double-check your work.

Write your answer to question 21 in the lined space provided below.

<p>21 Based on the selection, describe three eating habits of the Pilgrims and give a reason for each one. Look at the examples in the boxes below, but use different examples in your answer.</p>	
Way the Pilgrims Ate	Reason
Example: People used bread as a plate.	Example: They did not have bowls.
<p>1. _____</p> <p>_____</p> <p>_____</p>	<p>1. _____</p> <p>_____</p> <p>_____</p>
<p>2. _____</p> <p>_____</p> <p>_____</p>	<p>2. _____</p> <p>_____</p> <p>_____</p>
<p>3. _____</p> <p>_____</p> <p>_____</p>	<p>3. _____</p> <p>_____</p> <p>_____</p>

Watching wriggly worms can be very interesting. Read this article about creating a worm farm and then answer the questions that follow.

Watching Worms

by Cassie Brenn

- 1 **W**orms help our gardens grow. They wriggle through the soil, breaking up chunks of dirt and making it loose. It's easier for plant roots to push through loose soil and grow deeper into the ground. The worm tunnels also leave spaces in the soil for water and air to reach the plant roots.
- 2 That's not all. Worms help feed the plants, too. They add important nutrients to the soil by eating dead plants and leaves that fall on the ground. The plants use the nutrients to make the food they need to grow big and strong.
- 3 **Follow these steps to create your own worm farm.**

Step 1: Wash and dry a clear plastic two-liter bottle. Ask an adult to cut off the top of the bottle, then poke a small hole in the bottom.

Step 2: Prepare some food for your worms. They eat things like fruit and vegetable peels, wilted lettuce leaves, and fallen leaves. With adult help, cut the food into tiny pieces.

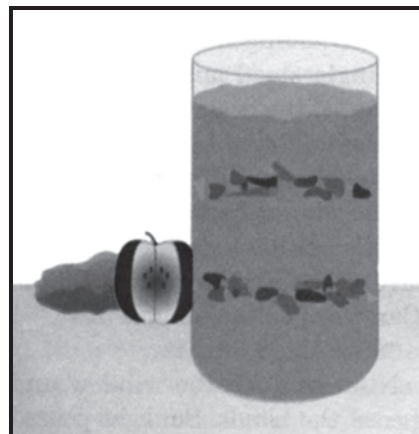

Step 3: Fill the bottom of the bottle with one or two inches of damp peat moss or soil. Next, add a layer of food. Keep layering until you fill the bottle three-quarters full. End with a layer of peat moss or soil on top.

Step 4: Put about ten worms on top of your worm farm. You can find worms under leaf piles, in compost bins, or at a store that sells fishing bait. Be sure to get the small, skinny red worms (also called *red wigglers* or *composting worms*). Worms don't like light, so they will quickly move underground.

Step 5: Tape a few sheets of newspaper or dark construction paper around the bottom three-fourths of the bottle to block out light. This will let the worms come to the sides of the bottle, where you can see them.

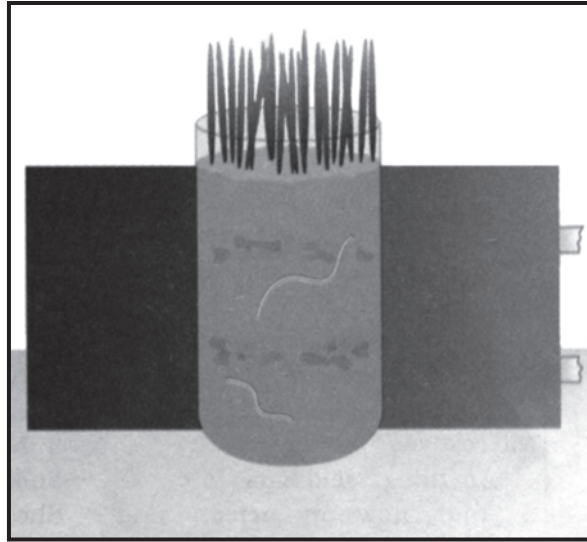

Step 6: For fun, scatter fast-growing seeds (such as grass seeds) across the top of the soil. Place your worm farm in a sunny location, and add water when needed to keep it moist.

- 4 To watch the worms at work, remove the paper covering. Replace the covering when you're not watching. When you're done with your worm farm, add the worms and soil to a garden.

Mark your choices for multiple-choice questions 22 through 25 by filling in the circle next to the best answer.

22 According to paragraph 1, how do worms help plants?

- (A) They eat the dead roots.
- (B) They loosen the soil.
- (C) They carry water deep into the soil.
- (D) They cut plant food into tiny pieces.

23 According to the article, which statement is **true**?

- (A) Worms like bright sunlight.
- (B) Worms must be near grass.
- (C) Worms eat vegetable peels.
- (D) Worms need very dry soil.

24 Based on the article, what is the purpose of creating a worm farm?

- (A) to sell worms
- (B) to study worms
- (C) to collect worms
- (D) to protect worms

25 What makes the article nonfiction?

- (A) It solves a problem.
- (B) It gives information.
- (C) It includes drawings.
- (D) It has many paragraphs.

English Language Arts

Reading Comprehension

SESSION 3

DIRECTIONS

This session contains three reading selections with sixteen multiple-choice questions and one open-response question. For multiple-choice questions, mark your answers by filling in the circle next to the best answer. For the open-response question, write your answer in the space provided below the question.

Here is a story about one lucky cat. Read the story to see what makes Moe McTooth so lucky. Then answer the questions that follow.



- 1 **M**oe McTooth was an outdoor cat.
- 2 By day he prowled Dumpsters and doorways.
- 3 By day he napped under the fruit stand.
- 4 By day he chased after dockside trucks for sardines that spilled like silver into his mouth.
- 5 By night Moe McTooth danced down alleys in the moonlight.
- 6 By night on back fences he wailed “The Fishmarket Blues.”
- 7 By night he stargazed from the tarry roof of the funnel factory.
- 8 And life was good.
- 9 Then came winter.
- 10 By day big wet flakes of snow fell.
- 11 By night the wind was so cold that the moonlight creaked.
- 12 Slowly, Moe McTooth turned into a hungry fur sack of a cat.
Shivering in doorways. Shuddering on back fences.

13 **O**ne morning, as Moe lay huddled in the stuffing of a junked sofa,
a young woman came by.

14 She stopped. She looked at Moe McTooth. She lifted him into her
arms. She took him to her apartment three blocks away.

15 There Moe McTooth became an indoor cat.

16 By day he lapped cream from a blue saucer.

17 By day he scampered after catnip toys.

18 By day he napped among geraniums on the windowsill.



19 By night Moe McTooth curled up in the young woman's lap.

20 By night he purred in the glow of the fire.

21 By night he whiskered around the cozy rooms.

22 And life was good.

23 And yet . . .

24 There were times when the tree branches scraped against the window
in the dappled light.
25 When the late-night rattle of trucks promised surprises.
26 When the cold perfume of the outdoors seeped under the locked
apartment door.
27 And Moe McTooth's heart stirred.

28 **S**pring came.
29 The air was soft and sweet.
30 The neighborhood turned willowy green.
31 Red tulips bloomed.
32 The young woman opened windows to the new breeze.
33 She opened the door. Just a crack.
34 Heart pounding, Moe McTooth slipped out. He scooted up the street.
35 Half-dressed and barefooted, the young woman tried to catch him.
36 But Moe McTooth was gone.

37 All day the woman waited at the window.
38 All night she kept a small light burning.
39 But Moe McTooth did not return.
40 Not that day.
41 Not the next.
42 Sadly, the young woman washed the blue saucer.
43 Sadly, she put the catnip toys away.

44 And life was lonely.

45 Out on the streets Moe McTooth prowled the fruit market. The banana
man swatted him with a broom. "Shoo!"
46 Moe leaped onto a ladder. Purple paint spattered.
47 He fell asleep in an empty orange crate. Someone dumped him out.
"Sorry, kitty."

48 After several days Moe McTooth became lonely, too.
He missed the young woman. He missed the cozy apartment.
He missed his own blue saucer and catnip toys.

49 Finally, ear torn, fur matted, Moe McTooth found his way
back to the young woman's doorstep.

50 She squealed with delight. She lifted him into her arms.
She danced him around the apartment.

51 Once again, by day Moe McTooth was an indoor cat.
52 By day he lapped cream from his saucer.
53 By day he scampered after his catnip toys.
54 By day he napped among geraniums.
55 By night, however, Moe McTooth padded out the door into the cool,
starry air.

56 The young woman waved goodbye. "See you in the morning, Moe," she
called after him.

57 **O**ne night the young woman felt a stirring of her own. The sweet darkness
of Moe's outdoor world seemed to seep into her heart.

58 And so, when Moe stepped into the moonlight, the young woman followed.
59 Together they prowled the shadowy streets.
60 Together they listened to the silvery music of the outdoor café.

61 And when the city grew still and quiet, they climbed to the
roof of the apartment building.

62 Lazily, Moe McTooth gazed up at the stars. The young woman
made dreamy wishes.

63 Somewhere a distant train whistle sounded.

64 And life was good.
65 Together.

From MOE MCTOOTH, *An Alley Cat's Tale* by Eileen Spinelli, illustrated by Linda Bronson. Text copyright © 2003 by Eileen Spinelli. Illustrations copyright © 2003 by Linda Bronson. Reprinted by permission of Clarion Books, an imprint of Houghton Mifflin Company. All rights reserved.

Mark your choices for multiple-choice questions 26 through 32 by filling in the circle next to the best answer.

- 26 Where does the **beginning** of the story take place?

(A) outside in a city
(B) near a train station
(C) inside a cozy room
(D) in an apartment building

- 27 Reread paragraph 4. The author compares sardines to

(A) silver.
(B) trucks.
(C) the day.
(D) a mouth.

- 28 Read paragraphs 25–27 in the box below.

When the late-night rattle of trucks promised surprises.
When the cold perfume of the outdoors seeped under the locked apartment door.
And Moe McTooth’s heart stirred.

The paragraphs show that

(A) Moe wants to find a friend.
(B) Moe misses being outdoors.
(C) Moe is grateful to the young woman.
(D) Moe is frightened by the sound of the trucks.

- 29 Based on the story, why does the young woman put Moe’s saucer and toys away?

(A) She thinks Moe has left forever.
(B) She knows his things are broken.
(C) She feels Moe is too old for them.
(D) She wants to keep the apartment neat.

- 30 Which of the following words **best** describe Moe a few days after he leaves the apartment?

(A) purring and fat
(B) dirty and lonely
(C) angry and mean
(D) dancing and cheerful

- 31 In the story, how does Moe's life change when he returns to the apartment?

(A) He takes longer naps.
(B) He only goes out at night.
(C) The young woman shares Moe with the banana man.
(D) The young woman makes Moe a bed from an old crate.

- 32 Read the sentence from paragraph 11 in the box below.

By night the wind was so cold that the moonlight creaked.

What kind of word is *moonlight*?

(A) adjective
(B) contraction
(C) proper noun
(D) compound word

Question 33 is an open-response question.

- Read the question carefully.
- Explain your answer.
- Add supporting details.
- Double-check your work.

Write your answer to question 33 in the lined space provided below.

33 Based on the story, describe how Moe’s life on the street is different from Moe’s life in the apartment. Support your answer with important details from the story.

In the Middle Ages, boys from important families were trained to be brave knights. Read this article to learn how they were prepared for knighthood. Then answer the questions that follow.

A Knight's Training

by Patricia Werner

Students read a selection titled "A Knight's Training" and then answered questions 34 through 37 that follow on page 33 of this document.

Due to copyright restrictions, the selection cannot be released to the public over the Internet. For more information, see the copyright citation below.

From APPLESEEDS' December 2001 issue: Children of the Middle Ages, © 2001, Cobblestone Publishing, 30 Grove Street, Suite C, Peterborough, NH 03458. All Rights Reserved. Used by permission of Carus Publishing Company.

Due to copyright restrictions, the selection that appeared on this page cannot be released to the public over the Internet. For more information, see the citation on the previous page.

Mark your choices for multiple-choice questions 34 through 37 by filling in the circle next to the best answer.

34 According to the article, how was Sir Godfrey different from some other knights?

- (A) He only cared about hunting.
- (B) He had many pages and squires.
- (C) He thought reading and writing were important.
- (D) He had a quintain for squires to practice jousting.

35 According to paragraph 4, a code of honor tells

- (A) how to prepare for battles.
- (B) how a knight must behave.
- (C) how to take care of a horse.
- (D) how a squire is different from a page.

36 According to the article, how did Nicholas's duties change when he became a squire?

- (A) He took care of the horses.
- (B) He worked for Sir Godfrey.
- (C) He learned to read and write.
- (D) He served Lady Catherine daily.

37 In paragraph 11, what does the word *unhorse* mean?

- (A) to climb down from a horse
- (B) to take the saddle off a horse
- (C) to knock someone off a horse
- (D) to take a horse away from someone

This is a story about John Henry, who was bigger, stronger, and faster than most men. Read the story and then answer the questions that follow.

JOHN HENRY

by
Julius Lester

Students read a selection titled “John Henry” and then answered questions 38 through 42 that follow on pages 36 and 37 of this document.

Due to copyright restrictions, the selection cannot be released to the public over the Internet. For more information, see the copyright citation below.

From JOHN HENRY by Julius Lester, copyright © 1994 by Julius Lester, text. Used by permission of Dial Books for Young Readers, A Division of Penguin Young Readers Group, A Member of Penguin Group (USA) Inc., 345 Hudson Street, New York, NY 10014. All rights reserved.

Due to copyright restrictions, the selection that appeared on this page cannot be released to the public over the Internet. For more information, see the citation on the previous page.

Mark your choices for multiple-choice questions 38 through 42 by filling in the circle next to the best answer.

- 38 In paragraph 1, the narrator uses the word “you” three times. In the paragraph, the narrator is speaking to

- (A) the reader.
- (B) the author.
- (C) John Henry.
- (D) Ferret-Faced Freddy.

- 39 In the story, what is the **first** clue that John Henry is an unusual person?

- (A) He chops down many trees.
- (B) He grows very large very quickly.
- (C) He chases the moon out of the sky.
- (D) He makes a deal with Ferret-Faced Freddy.

40 In paragraph 10, what does John Henry mean when he says, “Me on my legs”?

- Ⓐ He will run in the race.
- Ⓑ He will work hard all year.
- Ⓒ He thinks the race is unfair.
- Ⓓ He is walking straight and tall.

41 In paragraph 11, why does the author describe Freddy’s voice as “bat wings on tombstones”?

- Ⓐ to show that Freddy is sad
- Ⓑ to show that Freddy is scary
- Ⓒ to show that Freddy is funny
- Ⓓ to show that Freddy is brave

42 According to the story, what happens to Ferret-Faced Freddy after the race?

- Ⓐ He loses his horse.
- Ⓑ He grows even meaner.
- Ⓒ He wants to race again.
- Ⓓ He becomes a pleasant person.

Grade 3 English Language Arts
Reading Comprehension
Spring 2007 Released Items:
Reporting Categories, Standards, and Correct Answers

Item No.	Page No.	Reporting Category	Standard	Correct Answer (MC)*
1	11	<i>Reading and Literature</i>	12	C
2	11	<i>Reading and Literature</i>	8	B
3	11	<i>Reading and Literature</i>	8	C
4	11	<i>Reading and Literature</i>	8	C
5	12	<i>Reading and Literature</i>	12	A
6	12	<i>Reading and Literature</i>	8	D
7	12	<i>Language</i>	4	B
8	12	<i>Language</i>	4	C
9	14	<i>Reading and Literature</i>	14	C
10	14	<i>Reading and Literature</i>	14	D
11	14	<i>Reading and Literature</i>	14	D
12	14	<i>Language</i>	5	A
13	18	<i>Reading and Literature</i>	8	B
14	18	<i>Reading and Literature</i>	13	D
15	18	<i>Reading and Literature</i>	13	A
16	18	<i>Reading and Literature</i>	13	C
17	19	<i>Reading and Literature</i>	13	C
18	19	<i>Reading and Literature</i>	13	A
19	19	<i>Reading and Literature</i>	13	D
20	19	<i>Reading and Literature</i>	8	B
21	20	<i>Reading and Literature</i>	13	
22	23	<i>Reading and Literature</i>	13	B
23	23	<i>Reading and Literature</i>	13	C
24	23	<i>Reading and Literature</i>	13	B
25	23	<i>Reading and Literature</i>	10	B
26	28	<i>Reading and Literature</i>	8	A
27	28	<i>Reading and Literature</i>	15	A
28	28	<i>Reading and Literature</i>	15	B
29	28	<i>Reading and Literature</i>	12	A
30	29	<i>Reading and Literature</i>	12	B
31	29	<i>Reading and Literature</i>	12	B
32	29	<i>Language</i>	4	D
33	30	<i>Reading and Literature</i>	12	
34	33	<i>Reading and Literature</i>	13	C
35	33	<i>Reading and Literature</i>	13	B
36	33	<i>Reading and Literature</i>	13	B
37	33	<i>Language</i>	4	C
38	36	<i>Reading and Literature</i>	16	A
39	36	<i>Reading and Literature</i>	16	B
40	37	<i>Language</i>	6	A
41	37	<i>Reading and Literature</i>	15	B
42	37	<i>Reading and Literature</i>	16	D

* Answers are provided here for multiple-choice items only. Sample responses and scoring guidelines for open-response items, which are indicated by shaded cells, will be posted to the Department's Web site later this year.

III. English Language Arts, Grade 4

A. Composition

B. Reading Comprehension

Grade 4 English Language Arts Test

Test Structure

The grade 4 MCAS English Language Arts test was presented in the following two parts:

- the ELA Composition test, which used a writing prompt to assess learning standards from the Massachusetts *English Language Arts Curriculum Framework's* **Composition** strand
- the ELA Reading Comprehension test, which used multiple-choice and open-response questions (items) to assess learning standards from the *Curriculum Framework's* **Language** and **Reading and Literature** strands

A. Composition

The spring 2007 grade 4 MCAS English Language Arts Composition test and Composition Make-Up test were based on learning standards in the **Composition** strand of the Massachusetts *English Language Arts Curriculum Framework* (2001). The learning standards for the Composition strand appear on pages 72–83 of the *Framework*, which is available on the Department Web site at www.doe.mass.edu/frameworks/current.html.

In *Test Item Analysis Reports* and on the Subject Area Subscore pages of the MCAS *School Reports* and *District Reports*, ELA Composition test results are reported under the reporting categories **Composition: Topic Development** and **Composition: Standard English Conventions**.

Test Sessions and Content Overview

The MCAS ELA Composition test included two separate test sessions, administered on the same day with a short break between sessions. During the first session, each student wrote an initial draft of a composition in response to the appropriate writing prompt on the next two pages. During the second session, each student revised his or her draft and submitted a final composition, which was scored in the areas of Topic Development and Standard English Conventions. The MCAS Writing Score Guide (Composition Grade 4) is available at www.doe.mass.edu/mcas/student/scoring4.doc.

Reference Materials and Tools

At least one English-language dictionary per classroom was provided for student use during ELA Composition test sessions. The use of bilingual dictionaries was allowed for current and former limited English proficient students only. No other reference materials or tools were allowed during either ELA Composition test session.

Cross-Reference Information

Framework general standards 19–22 are assessed by the ELA Composition.

English Language Arts Composition, Grade 4

Grade 4 Writing Prompt

WRITING PROMPT

Think about the best time that you have ever had. Maybe you played all day with friends outside, went on a special trip, participated in a game, or spent some time at camp.

Write a story about this best time. What were you doing? Who was with you? Where were you? Why was this the best time ever? Give enough details in the story to show the reader what happened.

You may use the space below to plan what you are going to write (notes, outlines, other pre-writing activities).

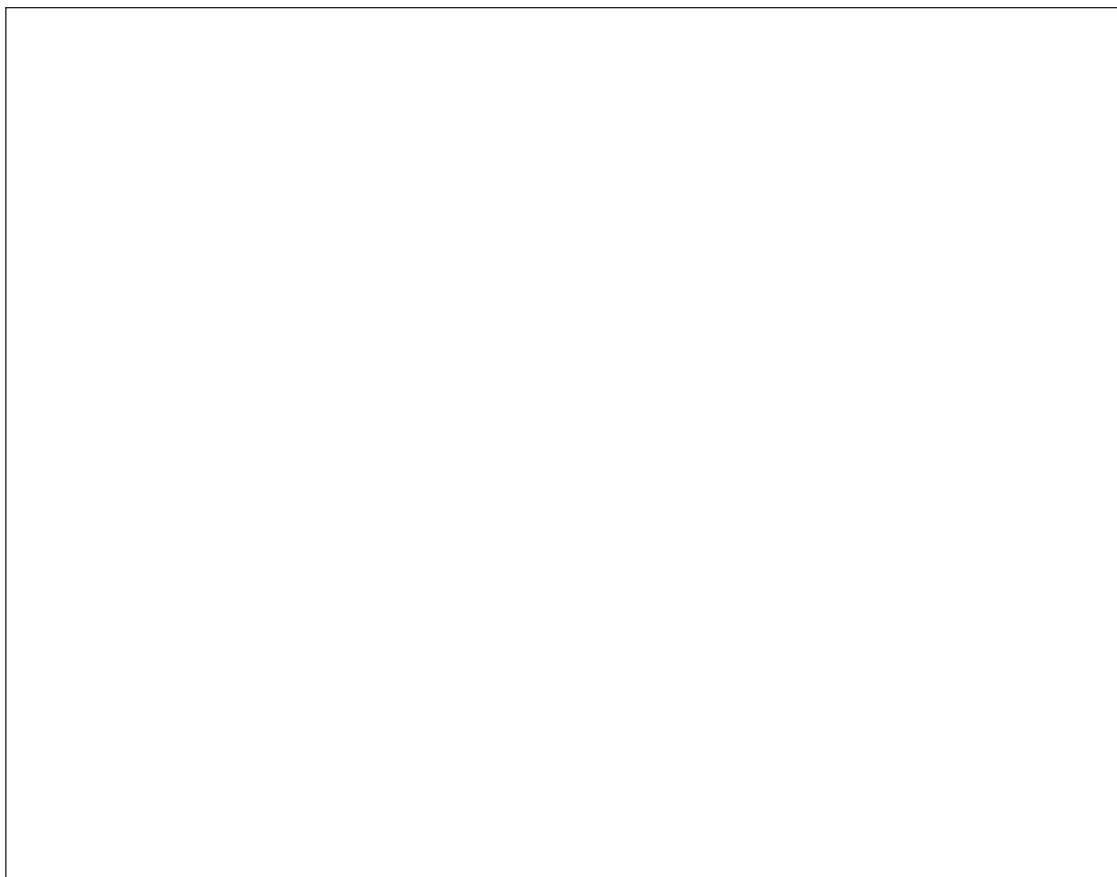

English Language Arts Composition, Grade 4

Grade 4 Make-Up Writing Prompt

WRITING PROMPT

Think about a time when you had a great adventure. It could have happened while on a school field trip, going to a relative's home, going on vacation, going to the movies, going to the library, or something totally different.

Write a story about this great adventure. Where did you go? What did you do? Who was with you? Give enough details to show the reader what happened and why the adventure was so great.

You may use the space below to plan what you are going to write (notes, outlines, other pre-writing activities).

B. Reading Comprehension

The spring 2007 grade 4 MCAS English Language Arts Reading Comprehension test was based on learning standards in the two content strands of the Massachusetts *English Language Arts Curriculum Framework* (2001) listed below. Page numbers for the learning standards appear in parentheses.

- Language (*Framework*, pages 19–26)
- Reading and Literature (*Framework*, pages 35–64)

The *English Language Arts Curriculum Framework* is available on the Department Web site at www.doe.mass.edu/frameworks/current.html.

In *Test Item Analysis Reports* and on the Subject Area Subscore pages of the *MCAS School Reports* and *District Reports*, ELA Reading Comprehension test results are reported under two MCAS reporting categories: **Language** and **Reading and Literature**, which are identical to the two *Framework* content strands listed above.

Test Sessions and Content Overview

The MCAS grade 4 ELA Reading Comprehension test included three separate test sessions. Each session included selected readings, followed by multiple-choice and open-response questions. Common reading passages and test items are shown on the following pages as they appeared in test booklets. Due to copyright restrictions, certain reading passages cannot be released to the public on the Web site. For further information, contact Student Assessment Services at 781-338-3625.

Reference Materials and Tools

The use of bilingual word-to-word dictionaries was allowed for current and former limited English proficient students only, during all three ELA Reading Comprehension test sessions. No other reference materials were allowed during any ELA Reading Comprehension test session.

Cross-Reference Information

The table at the conclusion of this chapter indicates each item's reporting category and the *Framework* general standard it assesses. The correct answers for multiple-choice questions are also displayed in the table.

English Language Arts

READING COMPREHENSION: SESSION 1

DIRECTIONS

This session contains three reading selections with fifteen multiple-choice questions and two open-response questions. Mark your answers to these questions in the spaces provided in your Student Answer Booklet.

Sitting at a restaurant in Mojave, California, in 1981, brothers Burt and Dick Rutan and their friend Jeana Yeager came up with an idea. They wanted to design an airplane that could fly nonstop all the way around the world. Would it be possible? Read the article to find out if they were able to make their dream happen. Answer the questions that follow.

Voyager's Amazing Journey

by Steve Osborn

- 1 Ever since the Wright brothers built the first airplane in 1903, planes had been getting bigger and faster. By the time Burt designed *Voyager*, some planes could carry hundreds of passengers, while others could go more than 2,000 miles an hour. Almost all these planes were built of a lightweight metal called aluminum. Yet, despite their size and speed, no plane had ever been able to fly nonstop around the world.
- 2 *Voyager* was neither big nor fast. In fact, its top speed was only 120 miles an hour. But *Voyager* could carry fuel—lots of fuel. It could carry so much fuel that Dick once called it a “flying gas tank.”
- 3 *Voyager* was made of a material called Hexcel honeycomb. This material is lighter than aluminum and seven times as strong. Thanks to Hexcel honeycomb, *Voyager*'s body weighed only 2,000 pounds, yet it could carry 7,000 pounds of fuel. If *Voyager* had been made of aluminum, it would have been able to carry only 1,000 pounds of fuel.
- 4 *Voyager* had two very long wings, a cockpit, and two propellers. It also had two smaller wings near the front propeller and two body parts called *booms*. The fuel was stored in the wings and the booms. Small pipes carried the fuel to the engines, which used the fuel to make the propellers move.
- 5 In the cockpit, Dick and Jeana used simple controls to steer the airplane and start the engines. The cockpit itself was very small—only three-and-a-half feet wide and seven-and-a-half feet long. It was also very loud

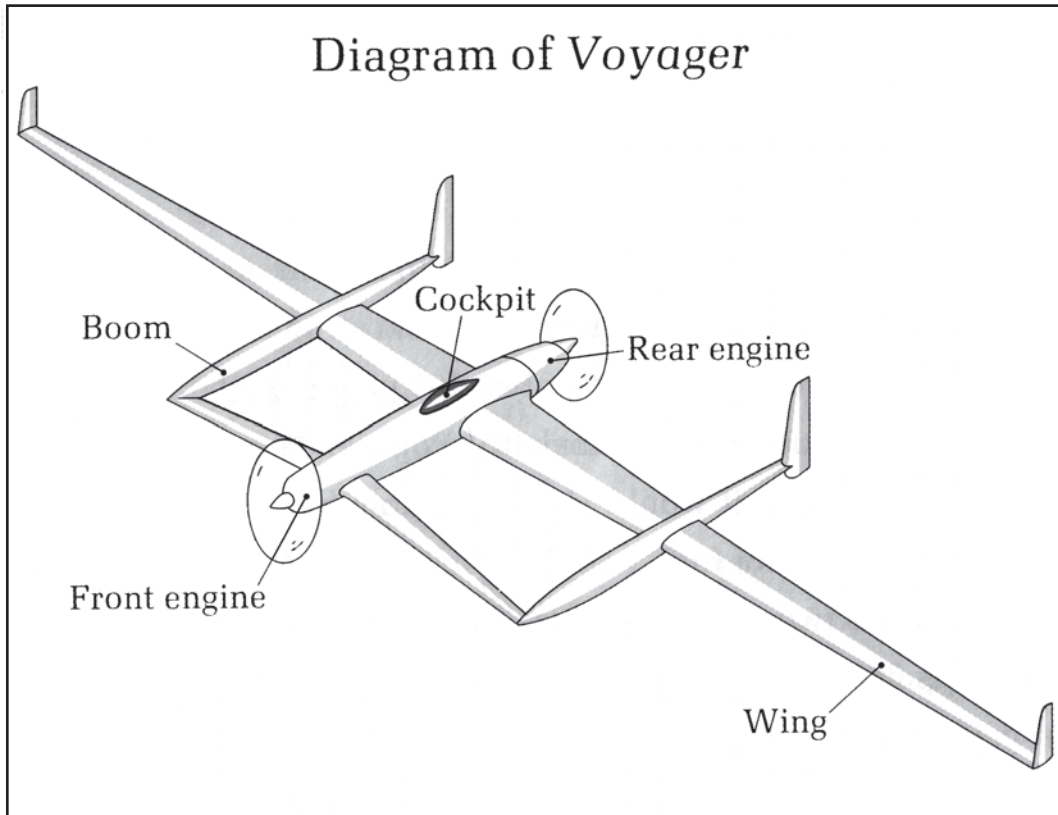

because it was so close to the engines. Dick and Jeana had to wear special headphones so they wouldn't become deaf from all the noise.

6 Soon after Burt designed the plane in 1981, the three of them started trying to raise enough money to build the plane. But no one was interested in their project. Some people said it wouldn't work, while others thought it was just a waste of money. Finally, a few airplane companies started donating materials. For example, one company donated lots of Hexcel honeycomb.

7 The free materials were nice, but they didn't pay all the bills. It took five years to build *Voyager*, and it cost almost two million dollars. Some of this money came from Burt, Dick, and Jeana; the rest came from sales of *Voyager* T-shirts and other souvenirs, as well as a few donations.

8 While they were building *Voyager*, Dick and Jeana prepared for their long flight. They did exercises to improve their muscles. They ate special foods to make their bodies stronger. And, most of all, they learned how to stay up for long periods of time. Dick and Jeana figured that their flight would last for at least nine days and nights. They would have to be wide awake during most of that time.

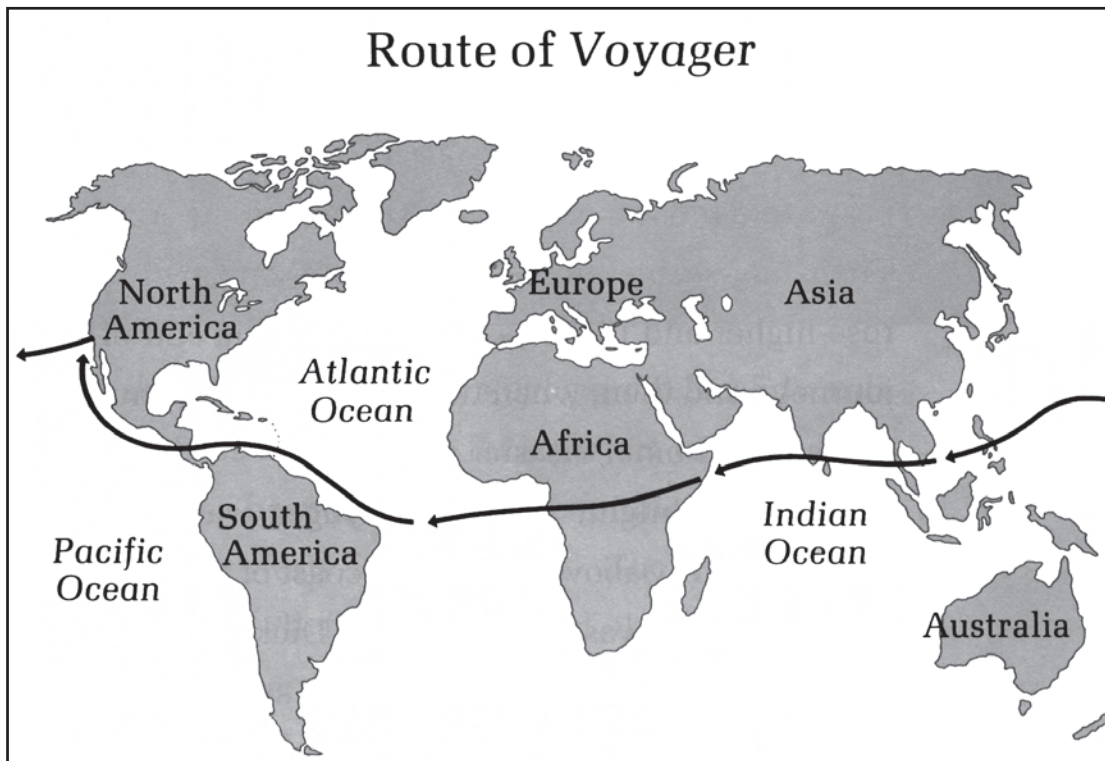

9 On December 14, 1986, *Voyager* was finally ready for its flight around the world. The plane sat at one end of a long runway at Edwards Air Force Base, just a few miles from the restaurant where it was created. Dick and Jeana walked around the plane one last time and then crawled into the small cockpit. Dick steered the plane, while Jeana worked the radio. They planned to switch back and forth throughout the long flight.

10 “Okay, you are cleared for takeoff,” said a voice from the control tower. Dick started the engines and moved the plane slowly down the runway. . . .

11 The map shows the route the *Voyager* took around the world. On the map, the route looks simple and direct, but the real story was quite different.

12 At the end of the second day of its flight, *Voyager* ran into a gigantic storm called a typhoon. The typhoon had winds of up to seventy-five miles an hour.

13 Dick and Jeana held on for dear life as the typhoon bounced their tiny plane back and forth like a boxer hitting a punching bag. Jeana was hurled around the cockpit and was soon covered with bruises. Somehow, Dick and Jeana managed to go on. They passed the storm and got back on course—but not for long.

14 A few short hours later, *Voyager* neared another storm. Dick and Jeana quickly decided to steer the plane in a giant circle and wait for the storm to

pass. Their plan worked, but it used up a lot of fuel. They began to wonder if they would have enough fuel left to make it home.

15 Everything went well for the next six days. Dick and Jeana gazed in wonder as they passed over the beautiful landscapes of Asia, Africa, and the Americas. Their fuel seemed to be holding out, and their spirits rose higher and higher as they neared the end of their journey. And then, when they were just a few hundred miles from home, disaster struck.

16 It was midnight, and the *Voyager* was humming along smoothly above the Pacific coast of Mexico. Only the rear engine was going, because Dick and Jeana had turned off the front engine in order to save fuel. All of a sudden, the rear engine stopped working. With both engines off, *Voyager* had nowhere to go but down.

17 Dick frantically tried to start the front engine as *Voyager* plunged lower and lower in the pitch-black sky. It fell a thousand feet, then two thousand, then three thousand. Finally, after a 3,500 foot drop, the front engine roared to life. If it hadn't, *Voyager* would have crashed into a watery grave.

18 The skies were cloudy as *Voyager* circled Edwards Air Force Base and came in for a perfect landing. Dick and Jeana had been flying nonstop for nine days, three minutes, and forty-four seconds. They had flown 25,012 miles—all the way around the world. What began as a conversation in a restaurant had ended as a triumph beyond Burt, Dick, and Jeana's wildest dreams.

19 They had set out to do the impossible and they had done it.

"*Voyager's* Amazing Journey" by Steve Osborn, from *Signposts*. Copyright © 1989 by Holt, Rinehart and Winston. Reprinted by permission of the author.

- 1 Based on paragraph 3, how did Hexcel honeycomb improve *Voyager's* chances of flying nonstop around the world?
- A. It allowed the airplane to travel faster.
 - B. It allowed the airplane to carry more fuel.
 - C. It allowed the airplane to have two engines.
 - D. It allowed the airplane to glide more smoothly.
- 2 Based on paragraph 5, how would the cockpit of *Voyager* **best** be described?
- A. warm and dark
 - B. noisy and crowded
 - C. bright and colorful
 - D. safe and comfortable

- 3 Read the sentence from paragraph 13 in the box below.

Dick and Jeana held on for dear life as the typhoon bounced their tiny plane back and forth like a boxer hitting a punching bag.

- Why does the author **most likely** use the simile, or comparison, in the sentence?
- A. to show that boxing is dangerous
 - B. to show how the pilots were injured
 - C. to show that flying a plane is an exciting sport
 - D. to show how the plane was affected by the storm

- 4 Read the sentence from paragraph 17 in the box below.

Dick frantically tried to start the front engine as *Voyager* plunged lower and lower in the pitch-black sky.

- What does the sentence tell about Dick?
- A. He was not familiar with the area.
 - B. He was not sure how to fly a plane.
 - C. He was worried about another storm.
 - D. He was scared that the plane would crash.

- 5 Read the sentence from paragraph 18 in the box below.

What began as a conversation in a restaurant had ended as a triumph beyond Burt, Dick, and Jeana's wildest dreams.

What is the main purpose of the sentence?

- A. to show that the team reached its goal
- B. to describe the team's work on the project
- C. to describe the plans for building *Voyager*
- D. to show that *Voyager's* flight was imagined

- 6 Which of the following facts does the map of *Voyager's* flight **best** show?

- A. The flight was mostly over water.
- B. The flight took nine days to complete.
- C. The flight began at Edwards Air Force Base.
- D. The flight ran into a typhoon in the Pacific Ocean.

- 7 Read the words from the article in the box below.

runway
headphones
honeycomb
takeoff

Which of the following statements is true about the words in the box?

- A. They are adjectives.
- B. They are contractions.
- C. They are proper nouns.
- D. They are compound words.

Question 8 is an open-response question.

- Read the question carefully.
- Explain your answer.
- Add supporting details.
- Double-check your work.

Write your answer to question 8 in the space provided in your Student Answer Booklet.

- 8 Based on the article, describe the problems that *Voyager's* team faced, both before **and** during the flight. Support your answer with important details from the article.

In this folktale, two young wives must agree to a difficult request before they can visit their friends in the old village. Will they be able to honor the request and return home? Read "The Lantern and the Fan" to find out, and answer the questions that follow.

THE LANTERN AND THE FAN

by Florence Holbrook

- 1 In a Japanese village there once lived a man who had two sons. When the sons were grown up, each brought home a wife from another village a long distance away. The father was greatly pleased with his two daughters-in-law, and for many months they all lived very happily together.
- 2 At last the two young wives asked to go home to visit their friends. Among the Japanese the sons and the sons' wives must always obey the father, so the two wives said, "Father-in-law, it is a long, long time since we have seen our friends. May we go to our old home and visit them?" The father-in-law answered, "No." After many months they asked again, and again he answered, "No." Once more they asked. The father-in-law thought, "They care nothing for me, or they would not wish to leave me, but I have a plan, and I can soon know whether they love their father-in-law or not." Then he said to the older of the two wives, "You may go if you wish, but you must never come back unless you bring me fire wrapped in paper." To the younger he said, "You may go if you wish, but you must never come back unless you bring me wind wrapped in paper." The father-in-law thought, "Now I shall find out. If they care for me, they will search the country through till they find paper that will hold fire and wind."
- 3 The two young wives were so glad to visit their old friends that for almost a month they forgot all about the gifts that they were to carry to their father-in-law. At last, when it was time to go home, they were greatly troubled about what they must carry with them, and they asked a wise man where to find the strange things. "Paper that will hold fire and wind!" he cried. "There is no such paper in Japan." The two women asked one wise man after another, and every one declared, "There is no such paper in Japan." What should they do? They feared they would never see their home again. They were so sad that they left their friends and wandered a long distance into the forest. Great tears fell from their eyes.
- 4 "I do not let people cry in my woods," said a voice. "My trees do not grow well in salt water."

5 The poor wives were so sorrowful that they forgot to be afraid, and the older one said, “Can we help crying? Unless I can carry to my father-in-law fire wrapped in paper, I can never go home.” “And I,” wailed the younger, “unless I can carry wind wrapped in paper, I can never go home. None of the wise men ever heard of such things. What shall we do?”

6 “It is easy enough to wrap fire in paper,” answered the voice. “Here is a piece of paper. Now watch.” They watched, and the strangest thing in all the world happened right before their eyes. There was no one to be seen, but a piece of paper appeared on the ground and folded itself into a Japanese lantern. “Now put a candle inside,” said the voice, “and you have paper holding fire. What more could you ask?”



7 Then the older woman was happy, but the younger was still sad. She saw now that fire could be carried in paper, but surely no one could carry wind. “O dear voice,” she cried, “can any one carry wind in paper?”

8 “That is much easier than to carry fire,” replied the voice, “for wind does not burn holes. Watch.”

9 They watched eagerly. Another piece of paper came all by itself and lay on the ground between them. There was a picture on it of a tree covered with white blossoms. Two women stood under the tree, gathering the blossoms.

10 “The two women are yourselves,” said the voice, “and the blossoms are the gifts that the father-in-law will give you when you go home.”

11 “But I cannot go home,” the younger wailed, “for I cannot carry wind wrapped in paper.”

12 “Here is the paper, and there is always plenty of wind. Why not take them?”

13 “Indeed, I do not know how,” the younger woman answered sorrowfully.

14 “This way, of course,” said the voice. Some long, light twigs flew to the paper. It folded itself, over, under, together. It opened and closed, and

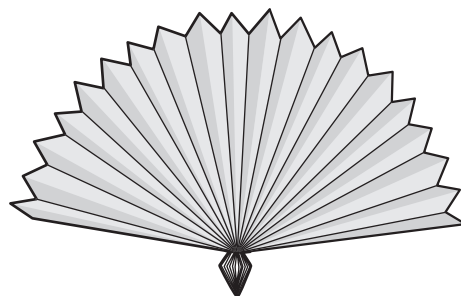

it waved itself before the tearful face of the younger woman. “Does not the wind come to your face?” asked the voice, “and is it not the fan that has brought it? The lantern carries fire wrapped in paper, and the fan carries wind wrapped in paper.”

- 15 Then, indeed, the two young women were happy, and when they came to the home of their father-in-law, he was as glad as they. He gave them beautiful gifts of gold and silver, and he said, “No one ever had such marvels before as the lantern and the fan, but in my home there are two more precious things than these, and they are my two dear daughters.”

In the public domain.

- 9 In paragraph 2, why does the father-in-law **most likely** tell the wives that they cannot leave?
- A. He does not like their friends.
 - B. He thinks that they will be lonely.
 - C. He is afraid that they will get lost.
 - D. He is worried that they do not love him.
- 10 According to paragraph 3, what problem do the wives have?
- A. They get lost in the woods at night.
 - B. They do not want to come home again.
 - C. They cannot find the gifts that they need.
 - D. They fight with their friends about the gifts.
- 11 Which event from the folktale allows the wives to return home?
- A. The wives receive gifts of gold and silver.
 - B. The wives visit their friends in their old village.
 - C. The voice begins to speak and guides them to the village.
 - D. The voice tells them how to make gifts for their father-in-law.
- 12 Read the sentence from paragraph 11 in the box below.
- “But I cannot go home,” the younger wailed, “for I cannot carry wind wrapped in paper.”
- What does the use of the word *wailed* tell readers about the younger wife?
- A. She is hurt.
 - B. She is upset.
 - C. She is angry.
 - D. She is confused.

Have you ever had a special pet? Read the poem about getting a puppy and answer the questions that follow.

BUYING A PUPPY

Students read a selection titled “Buying a Puppy” and then answered questions 13 through 17 that follow on pages 57 and 58 of this document.

Due to copyright restrictions, the selection cannot be released to the public over the Internet. For more information, see the copyright citation below.

“Buying a Puppy” from MERLIN AND THE SNAKE’S EGG by Leslie Norris. The Viking. Copyright © 1978 by Leslie Norris. Used by permission of Brandt & Hochman Literary Agents, Inc.

Due to copyright restrictions, the selection that appeared on this page cannot be released to the public over the Internet. For more information, see the citation on the previous page.

13 Look at the chart below.

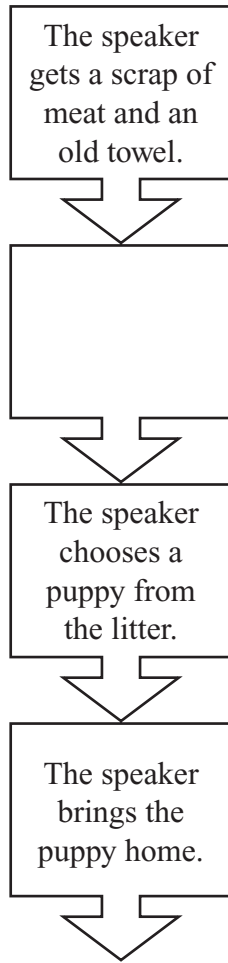

Which of the following events from the poem **best** belongs in the second box?

- A. The speaker lets the puppy sleep.
- B. The speaker turns eight years old.
- C. The speaker goes to see the puppies.
- D. The speaker comes home from school.

14 Based on the poem, which word **best** describes the puppy on the ride home?

- A. brave
- B. hungry
- C. excited
- D. peaceful

15 How are the last two stanzas different from the rest of the poem?

- A. They describe a different pet.
- B. They describe a different time.
- C. They describe a different town.
- D. They describe a different house.

16 Why is “Silk” capitalized in line 20?

- A. It is a type of dog.
- B. It is a proper noun.
- C. It is the name of a type of cloth.
- D. It is the first word of a sentence.

Question 17 is an open-response question.

- **Read the question carefully.**
- **Explain your answer.**
- **Add supporting details.**
- **Double-check your work.**

Write your answer to question 17 in the space provided in your Student Answer Booklet.

- 17** Describe the different feelings that the speaker has throughout the poem. Support your answer with important details from the poem.

English Language Arts

READING COMPREHENSION: SESSION 2

DIRECTIONS

This session contains one reading selection with eight multiple-choice questions and one open-response question. Mark your answers to these questions in the spaces provided in your Student Answer Booklet.

Jane and her brothers and sisters are not ordinary cats. They have wings! Read the chapter from Jane on Her Own to learn more about these interesting cats. Answer the questions that follow.

from **JANE ON**
HER OWN
by Ursula K. Le Guin

1 IT WAS A WARM AFTERNOON, and the six cats of Overhill Farm were lying about the barnyard, snoozing and talking, yawning at butterflies, purring in the sun.

2 Alexander Furby, who lived up at the farmhouse, came every day to visit Thelma and Roger, Harriet and James, and their little sister, Jane, who all lived in the barn loft.

3 It was Jane who sat up suddenly. “Thelma!” she said. “Why do we have wings?”

4 “We don’t know, Jane,” her big sister answered. “Our mother didn’t have wings. Alexander doesn’t. Most cats don’t. We don’t know why we do.”

5 “I know why!” said Jane.

6 “Why?” said Thelma.

7 “To fly with!” Jane shouted, and she flew straight up in the air, turned two somersaults and a loop-the-loop, stalled, and crashed right on top of Alexander Furby.

8 Alexander was a fine, sweet cat, but rather lazy.

When his dear friend Jane dived out of the air and squashed him, he just sighed and said, “Oh, Jane, don’t!” And he went back to sleep, a little flatter than before.



9 “If we can fly,” said Jane, “why do we always have to stay here in the same place and never fly anywhere and never see anything?”

10 Her big brother Roger said, “Oh, Jane, you know why.”

11 Her big sister Harriet said, “Because if human beings saw cats with wings, they’d put us in cages in zoos.”

12 Her big brother James said, “Or they’d put us in cages in laboratories.”

13 “Being different is difficult,” Thelma said. “And sometimes very dangerous.”

14 “I know, I know,” Jane said. She flew off and made faces at a woodpecker in one of the oak trees near the barn. To herself she said, “But I like difficult



things, and I like dangerous things, and everything here is boring!”

15 She saw Hank and Susan coming over the hill with a bag of fresh kibble.* She called down to the others, “Hank and Susan are human beans, and they didn’t put us in cages!”

16 “Hank and Susan are human be-ings,” James said carefully, “but they are special ones.”

17 Jane wasn’t listening. She was flying higher and higher all by herself and singing, “Me-me-me-me-me-me-meeee!”

18 That was a whisper-song she had sung to herself when she was a tiny kitten. Her mother had been chased away from her. Jane had hidden all alone in an attic full of hungry, angry rats. Here on the farm she didn’t think about that terrible time anymore. But when she was unhappy, she sang her old song, “Me-me-me-me-me-me-meeee!”

19 She was unhappy now because everything was always the same, and everybody was always the same, and she wanted to see new places and find new friends. If her brothers and sisters and Alexander were all content to stay here, well, they could stay here, but she was going to stretch her wings.

* *kibble* — a type of pet food made from grain

- 20 The next morning she did just that. She flew up over the barn roof, and the wind was so sweet and fresh that she knew it was time to go. Alexander was just coming over the hill. She swooped down and kissed his pink nose. “Good-bye. I’m going adventuring!” she called. And off she flew above the forest and the hills.
- 21 “Alexander will miss me,” she thought. But she knew that he would get over it, if he had plenty to eat. “And I will miss them all,” she thought. But she knew that she would get over it, because there were adventures waiting, and the wind was blowing, and she was on the wing.

From JANE ON HER OWN – A CATWINGS TALE by Ursula LeGuin. Text copyright © 1999 by Ursula K. LeGuin. Illustrations copyright © 1999 by S.D. Schindler. Reprinted by permission of Orchard Books, an imprint of Scholastic Inc.

- 18 Which of the following events happens **first** in the chapter?
- A. Jane starts singing to herself.
 - B. Jane asks why she has wings.
 - C. Jane flies away on an adventure.
 - D. Jane says that the farm is boring.
- 19 Where does **most** of the chapter take place?
- A. in the forest
 - B. in a large city
 - C. at Overhill Farm
 - D. at Alexander Furby’s house
- 20 According to the chapter, how are Jane and Alexander different from each other?
- A. Jane is a cat and Alexander is not.
 - B. Jane has wings and Alexander does not.
 - C. Alexander is new to the farm and Jane is not.
 - D. Alexander has a large family and Jane does not.
- 21 What does paragraph 7 suggest about Jane’s character?
- A. She is rude and selfish.
 - B. She is patient and calm.
 - C. She is nervous and fearful.
 - D. She is energetic and daring.

- 22 According to the chapter, why do the cats with wings think they have to stay at Overhill Farm?
- A. They would miss their mother if they left.
 - B. They would get lost if they left.
 - C. They might run out of food to eat if they left.
 - D. They might be captured if they left.
- 23 Based on the chapter, which of the following **most likely** describes what will happen next in the book?
- A. There will be a new setting.
 - B. There will be a different main character.
 - C. Jane will stay at Overhill Farm.
 - D. Jane will take Alexander with her on her travels.

- 24 Read the sentence from paragraph 8 in the box below.

When his dear friend Jane dived out of the air and squashed him, he just sighed and said, “Oh, Jane, don’t!”

Which of the following words in the sentence is a verb?

- A. dear
 - B. friend
 - C. air
 - D. squashed
- 25 Paragraph 21 states that Jane was “on the wing.” What does “on the wing” **most likely** mean?
- A. Jane is sad.
 - B. Jane is late.
 - C. Jane is flying.
 - D. Jane is hurrying.

Question 26 is an open-response question.

- **Read the question carefully.**
- **Explain your answer.**
- **Add supporting details.**
- **Double-check your work.**

Write your answer to question 26 in the space provided in your Student Answer Booklet.

- 26 Based on the chapter, explain why Jane decides to go on an adventure. Support your answer with important details from the chapter.

English Language Arts

READING COMPREHENSION: SESSION 3

DIRECTIONS

This session contains two reading selections with thirteen multiple-choice questions and one open-response question. Mark your answers to these questions in the spaces provided in your Student Answer Booklet.

Dirt is not only fun to play in, but it is also a very important part of nature. Read the article about dirt, using the box of science terms to help you. Answer the questions that follow.

Diggin' Dirt

by Ellen R. Braaf

Science Terms

organic — made from living things
stresses — pushes and pulls on
crevices — cracks or splits in something
primitive — very simple
complex — having a large number of parts

- 1 **Dirt's gotten a bad rap.** How many times have you been warned “Don't get dirty” or been scolded for tracking dirt into the house? No one wants to be called “as dull as dirt” or to be treated “like dirt.”

...

- 2 **B**ut if you've ever felt oozy mud squishing between your toes or planted seeds in soil and watched them bloom into beautiful flowers, you know that dirt is amazing stuff!

- 3 Most of the things you see around you can be traced back to dirt—from the pizza you ate for lunch to the microchips in your computer. Dirt holds the roots of plants and supplies them with nutrients

so the plants can grow. (And without green plants, we'd have no food to eat and no oxygen to breathe.) Dirt is the home for countless living organisms. Just a handful contains more living things than all the men, women, and children on the face of the earth. And dirt is nature's great recycler. When plants and animals die, organisms in the dirt feed on them, releasing their

chemicals and energy into the soil for use by future generations.

- 4 So dirt is really one of the most important things there is! We need dirt as much as we need water and air and sunshine.



Lots of animals dig dirt. A pig's tough, flexible snout is as sensitive to touch as a human hand. It makes a great tool for digging up food.

Endangered Dirt

- 5 But there isn't as much dirt around as it might seem. The layer of soil covering the earth is only a few feet deep. It's like the thin skin on an apple—except this skin doesn't cover the whole apple.
- 6 Remember that 75 percent of the earth's surface is water. And mountains and deserts and ice-covered polar regions take up their share of the remaining land. Scientists estimate that only about 10 percent of the earth is covered with soil that is useful for farming. People, however, use lots of that valuable land not for farms but for their homes, highways, schools, and shopping malls.
- 7 Far from being "as common as dirt," soil is precious. Some types are even so rare as to be listed as endangered.

A Rocky Start

- 8 There hasn't always been dirt on earth. Like plants and animals, dirt had to evolve.
- 9 Scientists believe that life on earth first appeared in the oceans about two billion years ago, but living things didn't begin to make their way to dry land for another billion and a half years or more. During all that time, most dry land was very rocky. There may have been windblown sand dunes in desert regions and some gravelly rock particles in mountain valleys, but no fine dirt and rich soil as we know it today. Why not?
- 10 Because fertile soil—soil in which plants can grow—is made up of two kinds of components: finely crumbled rocks, which are rich in minerals, and organic material from rotting plants and animals, which is rich in energy and nutrition. These components had to work together over millions and millions of years to make today's dirt.

Life Depends on Dirt and Dirt Depends on Life

- 11 How is dirt made? When rock is exposed to the forces of nature, it breaks down into smaller and smaller pieces in a process called "weathering." During the heat of the day, a rock expands. At night, when the temperature cools, the rock contracts. This cycle stresses the rock and eventually cracks it apart. Or water can get into rock crevices and freeze. As the

ice expands, the rock fractures. Wind and rushing water can wear down rocks, too. The growth of plants, which send their roots into the soil, helps complete this weathering process. Over time, the roots break up the rocks into fine particles of dirt.

12 When, millions of years ago, primitive plants and animals moved out of the oceans to the land nearby, soil that could support an abundance of life began to form. The first land plants were small and simple. They could survive on the minerals in rocks along with air, sunlight, and rain. When they died and rotted, they left behind organic material, called humus, that would help feed other plants. Over time, as plants began to spread further inland, they became larger and more complex. Their roots broke up more rocks to help create more soil. Slowly, the world was covered with plants and soil.

13 Animals also began to inhabit the land, living off the plants. When they died, their bodies added to the organic

components of the soil, making it richer and able to support a greater variety of life. Eventually, the land became as full of life as the oceans.

...

Playing in the Dirt

14 It takes an amazingly long time for the weathering of rocks and the activities of animals and plants to produce dirt—as much as 1,000 years to form just one



inch of fertile soil. So, give dirt some respect. Remember, the whole history of humanity is wrapped up in the history of dirt. But sometimes the best thing to know about dirt is just that it's so much fun to play in.

Text reprinted by permission of Cricket Magazine Group, Carus Publishing Company, from ASK magazine July/August 2004, Vol. 3, No. 6, text © 2004 by Ellen R. Braaf. "Pig," image courtesy of Lynn Stone/Bruce Coleman Inc. "Boy Covered with Mud," image courtesy of C. Lockwood/Bruce Coleman Inc.

- 27 Read the sentences from paragraph 3 in the box below.

Dirt is the home for countless living organisms. Just a handful contains more living things than all the men, women, and children on the face of the earth.

The author **most likely** compares the number of organisms in a handful of dirt to the number of people on the earth to show that

- A. many things live in dirt.
- B. dirt and humans are the same.
- C. there are not many different types of people.
- D. people have not lived as long as there has been dirt.

- 28 According to the article, how is the layer of soil covering the earth different from the skin of an apple?

- A. Soil covers only part of the surface of the earth.
- B. Soil has more minerals than the skin of an apple.
- C. Soil is a different color than the skin of an apple.
- D. Soil forms a thick coating over the surface of the earth.

- 29 According to the article, fertile soil is made of

- A. water and plants.
- B. water and oxygen.
- C. crushed rocks and plants.
- D. crushed rocks and oxygen.

- 30 According to the article, what effect does weathering have on rock?

- A. It helps form humus.
- B. It makes organic material.
- C. It causes the rock to split apart.
- D. It allows the rock to become stronger.

- 31 Which of the following phrases is an opinion from the article?

- A. “. . . dirt had to evolve.”
- B. “. . . dirt is amazing stuff!”
- C. “. . . 75 percent of the earth’s surface is water.”
- D. “. . . roots broke up more rocks to help create more soil.”

- 32 In the article, how do headings like “Endangered Dirt” help the reader?
- A. They introduce a new topic in the article.
 - B. They show that the article presents opinions.
 - C. They use words that are defined in the article.
 - D. They explain information that is in the pictures.
- 33 What makes the article nonfiction?
- A. It takes place in the past.
 - B. It introduces facts about dirt.
 - C. It presents a problem and solution.
 - D. It describes dirt in an informal way.

- 34 Read the sentence from paragraph 11 in the box below.

As the ice expands, the rock fractures.

Which of the following words could replace the word *fractures*?

- A. cools
- B. grows
- C. breaks
- D. strengthens

Question 35 is an open-response question.

- Read the question carefully.
- Explain your answer.
- Add supporting details.
- Double-check your work.

Write your answer to question 35 in the space provided in your Student Answer Booklet.

- 35 The article states that “dirt is amazing stuff!” Based on the article, explain why dirt is so important. Support your answer with important information from the article.

Three traveling soldiers have a problem when they realize that they have no food. Will the villagers help them? Read *Stone Soup* to find out, and answer the questions that follow.

Stone Soup

A Russian folk tale

by James Buechler

Characters

SERGEANT

PETYA

SASHA

OLGA, *a seamstress*

VERA, *a baker*

DMITRI, *a carpenter*

ANNA

MARYA

OTHER VILLAGERS

TIME: *Two hundred years ago.*

SETTING: *A village street in old Russia. Three houses stand along the street, and through large windows we see the interior of each house—a carpenter's shop, a bakery, and a seamstress's shop. There is a stream with stones right.*

AT RISE: *DMITRI is at work in the carpenter's shop, VERA works in the bakery kitchen, and OLGA sits sewing in the seamstress's shop. Three soldiers enter, and walk down the street. SERGEANT carries an old-fashioned rifle; PETYA, a knapsack; SASHA, a large cooking pot.*

10 SERGEANT (*To soldiers*): Cheer up, you two! We've come through the forest safely. I'm sure the people of this village will share their dinner with us.

SASHA: I hope so. My stomach is empty. It feels like a cave. (SERGEANT *knocks at OLGA's door.*)

OLGA (*Calling out of her window*): Who is it?

15 SERGEANT: Only three loyal soldiers, tramping home across Russia, after fighting for the Czar.¹ Can you spare us some food, good woman?

OLGA: Food! No, I have nothing. Our harvest was bad. You will find nothing here. (*Turns from window*)

PETYA (*Knocking at VERA's door*): Hello in there!

¹ Czar — the ruler of Russia

- 20 VERA (*At window*): What is it you want?
PETYA: Some supper, if you have any. Here are three loyal soldiers tramping home across Russia.
VERA: I am sorry to see you so hungry, but you have come to the wrong shop. It is everyone for himself in these times! (*Turns away*)
- 25 SASHA (*Losing his patience*): Let's see if our luck is better here. (*Knocks at DMITRI's door.*)
DMITRI (*Angrily*): Who are you, anyway? Sensible men are inside their houses, working.
SASHA: Three soldiers, sir. It would be kind of you to share your dinner
30 with us.
DMITRI: I have just enough dinner for myself. If I share, I eat one quarter of a dinner, and so do you (*Pointing*), and you, and you. We shall all be hungry afterward. What good will that be? No, I do not believe in sharing. It is a very bad idea. (*Turns away*)
- 35 PETYA: What selfish people these are!
SASHA (*Decisively*): They do not know how to share.
SERGEANT: Let's teach this fellow a lesson!
PETYA: No, no! We won't rob anyone.
SERGEANT: Of course not, Petya. All I meant was to teach these peasants to
40 make stone soup.
SASHA (*Catching on*): Aha, stone soup!
PETYA (*Laughing*): Just the thing. (*The three huddle together, whispering. Meanwhile, DMITRI comes to window again.*)
DMITRI: Still here, you vagabonds?² If you have no food, it's your lookout.
45 Why aren't you on your way?
SERGEANT (*Pretending not to hear*): Firewood, Sasha! Prepare the kettle, Petya. We will build our fire here, on this spot. (*SASHA goes off left; PETYA finds two Y-shaped sticks on the ground.*)
PETYA: We can use these to hang the kettle, Sergeant. (*Sets sticks in place*)
50 SERGEANT: Perfect, Petya. Now for the stones. We must see if they have nourishing stones in this village. Go and find some in that stream over there. (*PETYA takes kettle to right and throws some stones noisily into it. OLGA and VERA turn to windows, watching him. SASHA enters with dead branch.*) Good! That will burn well and heat our soup quickly. (*SASHA lays
55 fire, pretends to light it.*)

² *vagabonds* — people who move from place to place without a fixed home

SASHA: What kind of stones will we use for our soup tonight?

SERGEANT: What kind do you want?

SASHA: Oh, something filling! Granite is a good stone, now. I always like a granite soup. It has body. It sticks to your ribs! (PETYA *brings kettle to center, rattling stones*. DMITRI, VERA, and OLGA *leave houses, come near fire*. ANNA and MARYA *enter, followed by OTHER VILLAGERS*.)

DMITRI (*Tugging SERGEANT'S sleeve*): Excuse me.

SERGEANT: Eh? Oh, it is you, my friend.

DMITRI: I do not understand. What did you say you are cooking here?

65 SERGEANT (*In an offhand manner*): Just a stone soup. (*With sudden friendliness*) Tell me, what kind of stone do you like yourself? You might help us choose.

DMITRI: I! Why, I never heard of making soup from stones!

SASHA: Never heard of Stone Soup?

70 PETYA: I don't believe it.

SERGEANT (*To DMITRI*): Come, sir. If you are not joking, you must dine with us. (*PETYA rattles kettle*.) Have you some good stones there, Petya? Let Sasha choose tonight.

SASHA (*Examining stones*): Hm-m! This chunky one—it will be good! Washed down from the mountains, it has a flavor of snow on it. Ugh! Throw that one away. A flat stone, a flat taste.

PETYA: How about the red one?

SERGEANT: No, no, that is only an old fireplace brick—it will have a smoky taste. Nothing but fresh stones tonight. We shall have a guest.

80 SASHA: Fill the kettle, Petya. My fire is ready. (*PETYA dips water from well into kettle and hangs kettle over fire*.)

SERGEANT (*To DMITRI*): Have you a spoon? We soldiers often make do with a stick. But for a guest, the soup will need proper stirring and tasting.

DMITRI: I have just the thing—it has a nice long handle. It is in perfect condition.

85 I have not had guests in five years.

SERGEANT (*Clapping him on back*): Splendid, you generous man! (*DMITRI goes inside for spoon*.)

ANNA (*To MARYA*): What's this? The soldiers are making a soup from stones?

MARYA (*Nodding*): Stones from our own brook. That soldier put them in. I saw him myself.

SASHA (*Sniffing*): Oh, it makes me hungry!

DMITRI (*Returning with spoon*): Here you are. Please be careful.

- SERGEANT: Sir, you shall be served first. (*Stirs, tastes.*)
- MARYA: I am more hungry than usual. It must be the smell of this soup they
95 are cooking.
- ANNA: I must have a cold, for I can smell nothing.
- MARYA (*Sniffing*): Yes, I am very hungry, indeed. I have worked in the fields
since morning, with no lunch, either. What good soup! (SERGEANT, SASHA,
and PETYA each taste by turns, and smack lips.)
- 100 OLGA: Is it good?
- PETYA: Good.
- DMITRI: Good? (*Reaches for spoon*)
- SASHA (*Keeping spoon away from him*): Oh, so good!
- SERGEANT: It might stand an onion, though. Onion is very good for pulling the
105 flavor from a stone.
- OLGA: You know, I might find an onion in my house.
- 1ST VILLAGER: Hurry then, Olga. Get some. (OLGA *exits.*)
- SASHA (*Tasting*): A whiff of carrot, Sergeant? (VILLAGERS *look at each other.*)
- VERA: Perhaps I could fetch some carrots for this soup.
- 110 SERGEANT: That is gracious of you. And will you bring a bowl for yourself,
as well? You must dine with us. (VERA *goes inside as OLGA returns with
onions.*)
- OLGA: Use what you like. I should like to learn to make this soup. (SERGEANT
adds onions, tastes. PETYA tastes also.)
- 115 PETYA: Just a bit of potato, perhaps? I cannot say that stone soup is ever quite
right without a potato or two.
- OLGA: That is true. A stone is certainly nothing without a potato! (VERA *returns
with carrots and bowl. SERGEANT adds carrots.*)
- MARYA (*To VILLAGERS*): Vera was invited, did you hear? How can we be invited
120 as well? (*They whisper together. ANNA goes off right. MARYA calls out*) If
you need some potatoes for that soup of yours, I have a sack in my cottage!
(ANNA *appears with sack. Both give it to SERGEANT.*)
- SERGEANT: Many thanks. Please stay for dinner. And now, Sasha, to business!
(*Tasting*) Add a potato. . . . another another. (SASHA *is already ahead
of SERGEANT'S count.*) No, stop, Sasha. Stop!
- 125 DMITRI: What is the matter, Sergeant?
- SERGEANT: Too many potatoes! The potatoes have absorbed the flavor of the
stones.
- VILLAGERS (*Ad lib*): Oh, too bad! What a shame! (*Etc.*)
- 130 MARYA: Is there nothing we can do?

- PETYA: I have a suggestion. Meat and potatoes go well together. Let's add some meat.
- DMITRI: I have a ham that will do the trick. Wait here. (*Goes inside*)
- SERGEANT: It might work, at that. (DMITRI *returns with ham.*)
- 135 2ND VILLAGER: Good for you, Dmitri!
- 1ST VILLAGER: Quick thinking!
- All (*Applauding*): Hurrah, hurrah! (SERGEANT *adds ham.*)
- MARYA: Can anyone make this stone soup?
- PETYA: Oh, yes. All you need are stones, fire, water—and hungry people.
- 140 ANNA (*Impatiently*): Well, how is it now, soldier? It smells delicious.
- SERGEANT (*Tasting*): Hm. Some stones, as you may know, contain salt in them. These from your brook do not seem to be that kind. (OLGA *goes inside.*)
- OLGA (*Returning*): Here is your salt. (SERGEANT *adds salt, with flourish.*)
- SERGEANT: Friends, I know this will be a very good soup. You have fine stones
- 145 in this village, no doubt of that! Stay and eat with us, one and all. (VILLAGERS *cheer and mill about. 1ST VILLAGER goes offstage, returns at once with bowls. SERGEANT fills them and all taste soup.*)
- DMITRI: Truly a delicious soup, soldiers!
- ANNA: A hearty flavor!
- 150 MARYA: It fills you up!
- DMITRI: And to think, neighbors, it's made only of stones! (SOLDIERS *now advance to stage front and hold out their bowls of soup.*)
- SOLDIERS (*To audience*): Yes, think! It's made only of stones! (*Curtain.*)

THE END

- 36 Read the sentences from line 12 of the play in the box below.

SASHA: I hope so. My stomach is empty. It feels like a cave.

What does Sasha mean in the sentences?

- A. He is very funny.
- B. He is very hungry.
- C. His stomach is large.
- D. His stomach is round.

- 37 Read the sentences from lines 23 and 24 of the play in the box below.

VERA: I am sorry to see you so hungry, but you have come to the wrong shop. It is everyone for himself in these times!

What does Vera mean when she says that it is “everyone for himself”?

- A. People do not like each other.
- B. People do not help each other.
- C. People do not know each other.
- D. People do not talk to each other.

- 38 In lines 31–34, what reason does Dmitri give for not wanting to share his food with Sergeant, Petya, and Sasha?
- A. He does not have anything to eat.
 - B. Everyone will get smaller helpings.
 - C. He does not know how to cook well.
 - D. Everyone will complain about his food.

- 39 Based on the play, what is the **main** reason that Sergeant, Petya, and Sasha make stone soup?

- A. They know the villagers are good cooks.
- B. They know the villagers enjoy stone soup.
- C. They want to make the villagers try stone soup.
- D. They want to trick the villagers into sharing food.

- 40 Read the sentences from lines 102 and 103 in the box below.

DMITRI: Good? (*Reaches for spoon*)
 SASHA (*Keeping spoon away from him*): Oh, so good!

What is the purpose of the phrases in parentheses?

- A. to describe the setting of the play
- B. to show the lines a narrator speaks
- C. to tell how the characters should act
- D. to give new information to the audience

**Grade 4 English Language Arts
Reading Comprehension
Spring 2007 Released Items:
Reporting Categories, Standards, and Correct Answers**

Item No.	Page No.	Reporting Category	Standard	Correct Answer (MC)*
1	48	<i>Reading and Literature</i>	13	B
2	48	<i>Reading and Literature</i>	13	B
3	48	<i>Reading and Literature</i>	15	D
4	48	<i>Reading and Literature</i>	13	D
5	49	<i>Reading and Literature</i>	13	A
6	49	<i>Reading and Literature</i>	13	A
7	49	<i>Language</i>	4	D
8	50	<i>Reading and Literature</i>	13	
9	54	<i>Reading and Literature</i>	16	D
10	54	<i>Reading and Literature</i>	16	C
11	54	<i>Reading and Literature</i>	16	D
12	54	<i>Language</i>	4	B
13	57	<i>Reading and Literature</i>	14	C
14	57	<i>Reading and Literature</i>	14	D
15	57	<i>Reading and Literature</i>	14	B
16	57	<i>Language</i>	5	B
17	58	<i>Reading and Literature</i>	14	
18	61	<i>Reading and Literature</i>	8	B
19	61	<i>Reading and Literature</i>	12	C
20	61	<i>Reading and Literature</i>	8	B
21	61	<i>Reading and Literature</i>	12	D
22	62	<i>Reading and Literature</i>	8	D
23	62	<i>Reading and Literature</i>	12	A
24	62	<i>Language</i>	5	D
25	62	<i>Language</i>	4	C
26	62	<i>Reading and Literature</i>	12	
27	66	<i>Reading and Literature</i>	13	A
28	66	<i>Reading and Literature</i>	8	A
29	66	<i>Reading and Literature</i>	8	C
30	66	<i>Reading and Literature</i>	8	C
31	66	<i>Reading and Literature</i>	13	B
32	67	<i>Reading and Literature</i>	13	A
33	67	<i>Reading and Literature</i>	10	B
34	67	<i>Language</i>	4	C
35	68	<i>Reading and Literature</i>	13	
36	74	<i>Reading and Literature</i>	17	B
37	74	<i>Language</i>	4	B
38	74	<i>Reading and Literature</i>	17	B
39	74	<i>Reading and Literature</i>	17	D
40	74	<i>Reading and Literature</i>	17	C

* Answers are provided here for multiple-choice items only. Sample responses and scoring guidelines for open-response items, which are indicated by shaded cells, will be posted to the Department's Web site later this year.

IV. English Language Arts, Reading Comprehension, Grade 5

Grade 5 English Language Arts Reading Comprehension Test

The spring 2007 grade 5 MCAS English Language Arts Reading Comprehension test was based on learning standards in the two content strands of the Massachusetts *English Language Arts Curriculum Framework* (2001) listed below. Specific learning standards for grade 5 are found in the *Supplement to the Massachusetts English Language Arts Curriculum Framework* (2004). Page numbers for the learning standards appear in parentheses.

- Language (*Framework*, pages 19–26; *Supplement*, page 10)
- Reading and Literature (*Framework*, pages 35–64; *Supplement*, pages 11–13)

The *English Language Arts Curriculum Framework* and *Supplement* are available on the Department Web site at www.doe.mass.edu/frameworks/current.html.

In *Test Item Analysis Reports* and on the Subject Area Subscore pages of the MCAS *School Reports* and *District Reports*, ELA Reading Comprehension test results are reported under two MCAS reporting categories: **Language** and **Reading and Literature**, which are identical to the two *Framework* content strands listed above.

Test Sessions and Content Overview

The MCAS grade 5 ELA Reading Comprehension test included three separate test sessions. Each session included selected readings, followed by multiple-choice and open-response questions. Common reading passages and test items are shown on the following pages as they appeared in test booklets. Due to copyright restrictions, certain reading passages cannot be released to the public on the Web site. For further information, contact Student Assessment Services at 781-338-3625.

Reference Materials and Tools

The use of bilingual word-to-word dictionaries was allowed for current and former limited English proficient students only, during all three ELA Reading Comprehension test sessions. No other reference materials were allowed during any ELA Reading Comprehension test session.

Cross-Reference Information

The table at the conclusion of this chapter indicates each item's reporting category and the *Framework* general standard it assesses. The correct answers for multiple-choice questions are also displayed in the table.

English Language Arts

READING COMPREHENSION: SESSION 1

DIRECTIONS

This session contains three reading selections with sixteen multiple-choice questions and two open-response questions. Mark your answers to these questions in the spaces provided in your Student Answer Booklet.

Dogs are not just “man’s best friend”; they also do valuable work for us. Read “Lights, Camera, Barking!” and answer the questions that follow.

LIGHTS, CAMERA, BARKING!

The World of Dog Actors

by Kathiann M. Kowalski

Students read two selections titled “Lights, Camera, Barking!” and “All in a Day’s Work” then answered questions 1 through 9 that follow on pages 82–84 of this document.

Due to copyright restrictions, the selections cannot be released to the public over the Internet. For more information, see the copyright citation below.

“Lights, Camera, Barking! The World of Dog Actors” and “All in a Day’s Work” by Kathiann M. Kowalski, from ODYSSEY’s January 2005 issue: Dogs Rule!, © 2005, Carus Publishing Company, published by Cobblestone Publishing, 30 Grove Street, Suite C, Peterborough, NH 03458. All Rights Reserved. Used by permission of the publisher.

Due to copyright restrictions, the selection that appeared on this page cannot be released to the public over the Internet. For more information, see the citation on the previous page.

Due to copyright restrictions, the selection that appeared on this page cannot be released to the public over the Internet. For more information, see the citation on page 79.

- 1 What is the **most likely** reason the author asks questions in paragraph 1?
- A. to express doubt that dogs should be actors
 - B. to show a problem and solution in the article
 - C. to show that there is much to learn about dogs
 - D. to interest the reader in the subject of the article
- 2 Based on “Wanted: Professional, People-Loving Pooches,” which ability is most important in a dog trainer?
- A. the ability to think of creative plots
 - B. the ability to greatly encourage people
 - C. the ability to carefully observe behavior
 - D. the ability to see humor in all situations
- 3 Based on paragraphs 4–9, how would trainer Mathilde de Cagny **most likely** respond to a dog actor that liked to bark?
- A. She would reward him when he stopped barking.
 - B. She would encourage other dogs to play with him.
 - C. She would scold him until he did not bark anymore.
 - D. She would decide that he could not be trained as an actor.
- 4 Based on paragraph 9, what is **most** important to a trainer when working with a dog?
- A. the dog’s breed
 - B. the dog’s history
 - C. the dog’s personality
 - D. the dog’s appearance

5 According to “All in a Day’s Work,” which kind of dog watches over other animals?

- A. a guide dog
- B. a guard dog
- C. a therapy dog
- D. a herding dog

6 What is the purpose of the bullets (•) in “All in a Day’s Work”?

- A. to show where each new topic begins
- B. to point out the most important words
- C. to direct readers to other sections of the article
- D. to identify words that are defined in the article

7 Which meaning of the word *set* is used in paragraph 1?

- A. posture or pose
- B. a radio or television receiver
- C. a group of objects that are used together
- D. background scenery in a movie or on a stage

8 Read the sentence from paragraph 9 in the box below.

That means first thinking like a dog in general, and then putting yourself in the position of the unique animal you’re working with.

Based on the sentence, what is the meaning of the word *unique*?

- A. particular
- B. trained
- C. playful
- D. young

Question 9 is an open-response question.

- Read the question carefully.
- Explain your answer.
- Add supporting details.
- Double-check your work.

Write your answer to question 9 in the space provided in your Student Answer Booklet.

- 9 Based on the article, explain how dogs are trained to be actors **and** how they are treated while they are working. Support your answer with important information from the article.

Many poems have been written about the ocean. “The Sea” and “Long Trip” show two different ways poets use images to share their views and feelings about the ocean. Read the poems and answer the questions that follow.

The Sea

- The sea is a hungry dog,
 Giant and grey.
 He rolls on the beach all day.
 With his clashing teeth and shaggy jaws
 5 Hour upon hour he gnaws
 The rumbling, tumbling stones,
 And ‘Bones, bones, bones, bones!’
 The giant sea-dog moans,
 Licking his greasy paws.
- 10 And when the night wind roars
 And the moon rocks in the stormy cloud,
 He bounds to his feet and snuffs and sniffs,
 Shaking his wet sides over the cliffs,
 And howls and hollos long and loud.
- 15 But on quiet days in May or June,
 When even the grasses on the dune
 Play no more their reedy tune,
 With his head between his paws
 He lies on the sandy shores,
 20 So quiet, so quiet, he scarcely snores.

—James Reeves



Long Trip

- The sea is a wilderness of waves,
 A desert of water.
 We dip and dive,
 Rise and roll,
 5 Hide and are hidden
 On the sea.
 Day, night,
 Night, day,
 The sea is a desert of waves,
 10 A wilderness of water.

—Langston Hughes

“The Sea” © James Reeves from COMPLETE POEMS FOR CHILDREN (Classic Mammoth). Reprinted by permission of the James Reeves Estate. “Long Trip” by Langston Hughes. Reprinted by permission of Harold Ober Associates Incorporated. Copyright © 1994 by The Estate of Langston Hughes.

10 In lines 1–4 of “The Sea,” what is the poet describing with the image of the hungry dog rolling on the beach all day?

- A. waves carrying large stones
- B. waves coming in to the shore
- C. a boat floating in the ocean
- D. an animal running by the water

11 What do lines 10–14 of “The Sea” **mostly** describe?

- A. a wild and fierce sea at night
- B. a boat in danger on the ocean
- C. a person trying to climb a hill
- D. a lost and wet dog running home

12 Read lines 15–17 of “The Sea” in the box below.

But on quiet days in May or June,
When even the grasses on the dune
Play no more their reedy tune,

What does the description suggest?

- A. The day is calm.
- B. The grass is dying.
- C. The dune is hidden.
- D. The summer is over.

13 How are the first two lines of “The Sea” like the first two lines of “Long Trip”?

- A. The lines create a sense of peace.
- B. The lines rhyme with one another.
- C. The lines compare the sea to something else.
- D. The lines present an image of the sea’s beauty.

Anansi is a famous character in African folktales. He is a spider who is known as a trickster because he is crafty and sly. Read the folktale to find out how Anansi tricks Turtle. Answer the questions that follow.

Anansi and His Visitor, Turtle

by Edna Mason Kaula

Students read a selection titled “Anansi and His Visitor, Turtle” and then answered questions 14 through 18 that follow on pages 89 and 90 of this document.

Due to copyright restrictions, the selection cannot be released to the public over the Internet. For more information, see the copyright citation below.

“Anansi and His Visitor, Turtle”, from AFRICAN VILLAGE FOLK TALES by Edna Mason Kaula, copyright © 1968 by Edna Mason Kaula. Used by permission of Philomel Books, A Division of Penguin Young Readers Group, A Member of Penguin Group (USA) Inc., 345 Hudson Street, New York, NY 10014. All rights reserved.

Due to copyright restrictions, the selection that appeared on this page cannot be released to the public over the Internet. For more information, see the citation on the previous page.

- 14 In paragraph 2, what is the **main** reason that Anansi invites Turtle to dinner?
- A. Anansi is Turtle’s good friend.
 - B. Anansi knows he must be polite.
 - C. Anansi wants to ask Turtle for a favor.
 - D. Anansi has too much food to eat by himself.
- 15 In paragraph 4, what is the **most likely** reason that “Anansi was eating at a furious rate”?
- A. He was very hungry.
 - B. He wanted the food for himself.
 - C. He wanted to be sure the food was good.
 - D. He was trying to escape before Turtle returned.
- 16 In paragraph 6, what is the **main** reason that Turtle refuses to argue with Anansi?
- A. He wants to be better friends with Anansi.
 - B. He does not want to hurt Anansi’s feelings.
 - C. He is afraid Anansi will not give him food.
 - D. He has lost arguments with Anansi in the past.
- 17 In paragraph 6, what does the word **ravenous** mean?
- A. very careful
 - B. very hungry
 - C. very clean
 - D. very late

Question 18 is an open-response question.

- Read the question carefully.
- Explain your answer.
- Add supporting details.
- Double-check your work.

Write your answer to question 18 in the space provided in your Student Answer Booklet.

- 18 Explain how Anansi tricks Turtle **and** how Turtle tricks Anansi in the folktale. Support your answer with important details from the folktale.

English Language Arts

READING COMPREHENSION: SESSION 2

DIRECTIONS

This session contains one reading selection with eight multiple-choice questions and one open-response question. Mark your answers to these questions in the spaces provided in your Student Answer Booklet.

“Virgil” tells the story of one boy’s experiences trying to grow lettuce in a community garden. People in the neighborhood use an empty lot for garden plots; they share the space to grow their own vegetables and flowers. Read the story and answer the questions that follow.

VIRGIL



from Seedfolks, by Paul Fleischman

- 1 **M**y father drove a bus back in Haiti. Here he drives a taxi. That night he drove himself way across town to borrow two shovels from a friend of his. The next morning was the first day without school. I was done with fifth grade forever. I’d planned on sleeping till noon to celebrate. But when it was still half dark my father shook my shoulder. School was over, but that garden was just starting.
- 2 We walked down and picked out a place to dig up. The ground was packed so hard, the tip of my shovel bounced off it like a pogo stick. We tried three spots till we found one we liked. Then we walked back and forth, picking out broken glass, like chickens pecking seeds. After that we turned the soil. We were always digging up more trash—bolts and screws and pieces of brick. That’s how I found the locket. It was shaped like a heart and covered with rust, with a broken chain. I got it open. Inside was this tiny photo of a girl. She was white, with a sad-looking face. She had on this hat with flowers on it. I don’t know why I kept it instead of tossing it on our trash pile.

3 It seemed like hours and hours before we had the ground finished. We rested a while. Then my father asked if I was ready. I thought he meant ready to plant our seeds. But instead, we turned another square of ground. Then another after that. Then three more after that. My father hadn't been smiling to himself about some little garden. He was thinking of a farm, to make money. I'd seen a package of seeds for pole beans and hoped that's what we'd grow. They get so tall that the man in the picture was picking 'em way at the top of a ladder. But my father said no. He was always asking people in his cab about how to get rich. One of 'em told him that fancy restaurants paid lots of money for this baby lettuce, smaller than the regular kind, to use in rich folks' salads. The fresher it was, the higher the price. My father planned to pick it and then race it right over in his cab. Running red lights if he had to.

4 Lettuce seeds are smaller than sand. I felt embarrassed, planting so much ground. No one else's garden was a quarter the size of ours. Suddenly I saw Miss Fleck. I hardly recognized her in jeans. She was the strictest teacher in Ohio. I'd had her for third grade. She pronounced every letter in every word, and expected you to talk the same way. She was tall and even blacker than my father. No slouching in your seat in her class or any kind of rudeness. The other teachers seemed afraid of her too. She walked over just when we finished planting.

5 "Well, Virgil," she said. "You seem to have claimed quite a large *plantation* here."

6 That's just what I was afraid of hearing. I looked away from her, down at our sticks. We'd put 'em in the ground and run string around 'em, cutting our land up into six pieces. I didn't know why, till my father stepped forward.

7 "Actually, madam, only this very first area here is ours," he said. He had on his biggest smile. He must have remembered her. "The others we have planted at the request of relatives who have no tools or who live too far."

8 "Really, now," said Miss Fleck.

9 "Yes, madam," said my father. He pointed at the closest squares of land. "My brother Antoine. My auntie, Anne-Marie."

10 My eyes opened wide. They both lived in Haiti. I stared at my father, but he just kept smiling. His finger pointed farther to the left. "My Uncle Philippe." He lived in New York. "My wife's father." He died last year. "And her sister."

My mother didn't have any sisters. I looked at my father's smiling face. I'd never watched an adult lie before.

11 "And what did your *extended* family of gardeners ask you to plant?" said Miss Fleck.

12 "Lettuce," said my father. "All lettuce."

13 "What a coincidence," she said back. She just stood, then walked over to her own garden. I'm pretty sure she didn't believe him. But what principal could she send him to?

14 That lettuce was like having a new baby in the family. And I was like its mother. I watered it in the morning if my father was still out driving. It was supposed to come up in seven days, but it didn't. My father couldn't figure out why. Neither of us knew anything about plants. This wrinkled old man in a straw hat tried to show me something when I poured out the water. He spoke some language, but it sure wasn't English. I didn't get what he was babbling about, till the lettuce finally came up in wavy lines and bunches instead of straight rows. I'd washed the seeds out of their places.

15 The minute it came up, it started to wilt. It was like a baby always crying for its milk. I got sick of hauling bottles of water in our shopping cart, like I was some old lady. Then the heat came. The leaves shriveled up. Some turned yellow. That lettuce was dying.

16 My father practically cried, looking at it. He'd stop by in his cab when he could, with two five-gallon water containers riding in the back instead of passengers. Then bugs started eating big holes in the plants. I couldn't see anyone buying them from us. My father had promised we'd make enough money to buy me an eighteen-speed bike. I was counting on it. I'd already told my friends. My father asked all his passengers what to do. His cab was like a library for him. Finally, one of 'em told him that spring or fall was the time to grow lettuce, that the summer was too hot for it. My father wasn't smiling when he told us.

17 I couldn't believe it. I stomped outside. I could feel that eighteen-speed slipping away. I was used to seeing kids lying and making mistakes, but not grown-ups. I was mad at my father. Then I sort of felt sorry for him.

- 18 That night I pulled out the locket. I opened it up and looked at the picture. We'd studied Greek myths in school that year. In our book, the goddess of crops and the earth had a sad mouth and flowers around her, just like the girl in the locket. I scraped off the rust with our dish scrubber and shined up that locket as bright as I could get it. Then I opened it up, just a crack. Then I whispered, "Save our lettuce," to the girl.

TEXT COPYRIGHT © 1997 BY PAUL FLEISCHMAN. Used by permission of HarperCollins Publishers.

- 19 What do the details in paragraph 1 **best** show about Virgil's father?
- A. He is eager to plant a garden.
 - B. He is hoping to move back to Haiti.
 - C. He is angry that Virgil is still in bed.
 - D. He is confused about when school ends.

- 20 Read the sentences from paragraph 1 in the box below.

The next morning was the first day without school. . . . School was over, but that garden was just starting.

Based on the story, what does Virgil **most likely** mean by the sentences?

- A. School and the garden were both work for him.
- B. School and the garden were both new experiences for him.
- C. School and the garden were places where he saw his friends.
- D. School and the garden were places where he went with his father.

- 21 In paragraph 4, what does the description of Miss Fleck **best** show about her?
- A. She is starting a new job.
 - B. She has a garden larger than Virgil's.
 - C. She is one of Virgil's favorite teachers.
 - D. She expects everyone to behave properly.
- 22 In paragraph 8, what does Miss Fleck's comment **most likely** show about her attitude toward Virgil's father's explanation?
- A. She is pleased by his generosity.
 - B. She doubts that his story is true.
 - C. She is happy that his family is so large.
 - D. She wonders why he wants so much work.
- 23 In paragraphs 14 and 15, why does the author **most likely** compare the lettuce to a new baby?
- A. to show that the lettuce is very small
 - B. to show that the lettuce grows quickly
 - C. to show that the lettuce needs a lot of care
 - D. to show that the lettuce is special to Virgil
- 24 In paragraph 16, why is the cab "like a library" for Virgil's father?
- A. because he stores many possessions there
 - B. because he reads books there in his spare time
 - C. because he borrows items from his passengers
 - D. because he gets information from his passengers
- 25 In paragraph 17, what is the **most likely** reason that Virgil goes from feeling angry to feeling sorry for his father?
- A. Virgil knows his father will get him a bike later.
 - B. Virgil thinks his father made him work too hard.
 - C. Virgil understands that his father is disappointed.
 - D. Virgil realizes his father had a good time in the garden.
- 26 In paragraph 18, what is the **most likely** reason Virgil whispers, "Save our lettuce," to the girl in the locket?
- A. She has brought him good luck before.
 - B. She reminds him of a spirit of nature.
 - C. She seems like a kind person.
 - D. She looks like his aunt.

Question 27 is an open-response question.

- Read the question carefully.
- Explain your answer.
- Add supporting details.
- Double-check your work.

Write your answer to question 27 in the space provided in your Student Answer Booklet.

- 27 Explain how Virgil’s feelings toward the garden change from the beginning to the end of the story. Support your answer with important details from the story.

English Language Arts

READING COMPREHENSION: SESSION 3

DIRECTIONS

This session contains two reading selections with twelve multiple-choice questions and one open-response question. Mark your answers to these questions in the spaces provided in your Student Answer Booklet.

William Driver, a sea captain from Massachusetts, was the first person to use the nickname “Old Glory” to describe the American flag. His feelings for Old Glory were strong, even during the Civil War that divided the North and South in the United States. Read the selection about William Driver and Old Glory and answer the questions that follow.

“I’ll Call Her Old Glory”

by Teresa Bateman

- 1 **A** SALTY BREEZE skipped off Massachusetts Bay and blustered down the streets of Salem, calling young William Driver to the sea.
- 2 Born on Saint Patrick’s Day in 1803, William had grown up in Salem surrounded by fishermen and seafarers. He had stood on the creaking docks as sea gulls wheeled overhead, watching ships slip away with the ebbing tide. He had perched nearby as sailors told tales of dangerous seas and strange adventures in foreign ports.
- 3 When he was twelve, William begged his mother’s permission to ship out as a cabin boy on the sailing vessel *China*, bound for Leghorn, Italy. It would be a long voyage, but he looked forward to finally having a few adventures of his own.
- 4 The owner was a dour¹ man who had a low opinion of cabin boys.
- 5 “You’ll be paid five dollars a month, but it’s sure to be a waste of good money,” he said. “All boys on their first voyage eat more than they earn.”
- 6 William vowed to prove him wrong.
- 7 Boys often left home at an early age then, but it must have caused William’s mother some heartache to see the *China* disappear over the horizon, knowing it would be more than a year before she would see her son again. William may have felt a brief tug at his heart as well, but he had little time to be homesick.
- 8 The work was hard, and the days long, on board the *China*. As the youngest of the crew, William was given the chores no one else wanted to do. He found himself at the beck and call of every sailor on the ship. Perhaps they hoped to discourage him, but their efforts were in vain. Eighteen months of taut² sails against the sky, a sea

¹ *dour* — gloomy

² *taut* — tightly drawn

that constantly shifted and changed, the taste of salt, the sound of wind twanging the sheets,³ and William Driver knew where his life's work would be.

9 At the end of the voyage, when the *China* sailed again into Massachusetts Bay, the owner of the ship was so pleased with William's performance that he presented him with twenty-eight dollars in silver, over and above the five dollars a month wages the boy had been promised.

10 The road home seemed to dip and sway as William hurried to give the money to his mother and share with her his stories of the sea.

11 **T**his was the first voyage of many. William worked hard and was quickly promoted. At the age of eighteen, he became master of his first ship.

12 In 1821 the United States of America was a young country, less than fifty years old, but it had already gained a worldwide reputation after winning its independence from England. Americans were excited about their new nation and proud of its accomplishments. Sailors from the United States traveled the world, flying the American flag high for all to see. William was no different. If anything, he flew the flag more than most.



13 The first flag of the United States had thirteen stars and stripes. By 1831, twenty-four stars were scattered across the blue union. It was a twenty-four-star flag that was given to Captain Driver in August 1831 by a group of admiring citizens who knew he was about to sail around the world and wanted him to have a flag to remind him of home.

³ sheets — ropes used to adjust the sails on a boat

14 Ships' flags rarely lasted long. Ocean winds and rain soon left them tattered. This flag, however, was different. It had been made with Captain Driver in mind. It was large and sturdy—designed to withstand sea winds and salt air. It would serve him well on this, his ninth, voyage.

15 Delighted, William Driver immediately raised the flag over his ship, the *Charles Doggett*, until it unfurled in the stiff breeze. As he gazed up at the crisp colors of his new flag, he cried out, "I'll call her Old Glory, boys, Old Glory!"

16 The flag accompanied Captain Driver on all his voyages that followed—including two trips around the world. He sailed through storms, endured doldrums,⁴ and visited strange and exotic ports.

17 His constant travels gave him ample opportunity to fly his new flag but left little time for romance. Finally, he met a young woman from his hometown of Salem, Massachusetts. Her name was Martha Babbage. They were married, and Captain Driver continued his sailings. When Martha died, he felt his heart would break, but a few years later he met and married Sarah J. Parks of Nashville, Tennessee.

18 In 1837 Captain Driver sailed into port on his ship, the *Black Warrior*, and retired. At the age of thirty-four, he settled in Nashville, Tennessee, at the request of his second wife. Old Glory came with him, carefully preserved in the brassbound, camphor-wood sea chest that had accompanied the captain on all his voyages. . . .

19 The story of the flag became a local legend, and the captain earned the nickname of "Old Glory Driver." His fame, however, was based on sentiments that soon grew unpopular in Nashville. The nation was becoming divided over the issues of slavery and states' rights—a division that would soon lead to civil war. Captain Driver believed in keeping the country united. When Tennessee seceded⁵ from the Union in 1861, he found himself living on the wrong side of a war he did not believe in.

20 Although Captain Driver sympathized with the North, he lived in Tennessee and had married a Southern woman. Two of his sons fought for the Confederate army. Even in his own home, his views were discouraged.

21 William Driver's politics were as well known as his flag. He stood firm in his loyalty to the Union despite threats. Any American flag was fair game in Nashville, and Confederate sympathizers threatened to confiscate⁶ Old Glory as well. However, the flag had disappeared when the Civil War began. Although house and yard were repeatedly searched by Confederate troops, no trace was found of the flag. Those who intended to destroy it left disappointed. Captain Driver refused to discuss the flag's whereabouts. He was an old sea dog and had a few tricks of his own that his enemies could not fathom.⁷

22 Too old to fight, Captain Driver waited to see what would become of the country he loved. Would it stay fatally divided, or would his flag fly again, its stars intact?

⁴ *doldrums* — areas of light wind or no wind in the ocean that make sailing difficult

⁵ *seceded* — withdrew

⁶ *confiscate* — seize or steal

⁷ *fathom* — understand

- 23 In 1862 Union soldiers approached Nashville. Every effort was made to stop their advance. Supplies were quickly distributed to citizens or destroyed so they would not fall into the hands of the Union troops. Important records were moved out of the city. On the morning of 25 February, Union troops arrived, and Nashville surrendered. Many residents fled. Captain Driver, on the other hand, ran in exactly the opposite direction.
- 24 He welcomed the Union army and told them he had something they'd want to see. Accompanied by several soldiers of the Sixth Ohio Regiment, Captain Driver hurried home. Calling to his daughter, Mary Jane, he asked her to bring down a purple calico bedcover from upstairs.
- 25 Taking the comforter in his hands, he ripped it open, and there, stitched into the lining, was Old Glory. He had sewn the flag into the quilt for safekeeping.
- 26 At the sight of Old Glory, the soldiers cheered. They escorted Captain Driver as he marched with the flag to the statehouse.
- 27 A hush fell over the Union soldiers as they saw the folded flag. Though no longer a young man, Captain Driver climbed the stairs to the building's dome, took down the small regimental flag that had been flying there, and personally raised Old Glory over the capitol. As the old sea flag unfurled, a cheer rang out from the soldiers below.

...

Reprinted by permission of CRICKET magazine, July 2003, Vol. 30, No. 11, copyright © 2003 by Teresa Bateman.

- 28 In paragraphs 1 and 2, what is the **most likely** reason the author describes the events of William Driver's early childhood?
- A. to show why William wanted to become a sailor
 - B. to show why William had to work at a young age
 - C. to show why William wanted to please his mother
 - D. to show why William was afraid of visiting foreign lands

- 29 How does the selection change in paragraph 11?
- A. It moves ahead in time.
 - B. It becomes more dramatic.
 - C. It changes the point of view.
 - D. It tells about a different person.

- 30 What do the details in paragraph 16 **best** show about Old Glory?
- A. It lasted through some difficult and long voyages.
 - B. It brought Captain Driver good luck on his voyages.
 - C. It was a symbol of freedom and honor.
 - D. It reminded Captain Driver how much he missed home.

- 31 Read the sentence from paragraph 21 in the box below.

He was an old sea dog and had a few tricks of his own that his enemies could not fathom.

Based on paragraph 21, what does the sentence suggest?

- A. Captain Driver was thought to be a spy for the Union.
- B. Captain Driver had cut up Old Glory to make a quilt.
- C. Captain Driver was planning to join the Union navy.
- D. Captain Driver had hidden Old Glory from the soldiers.

- 32 Based on paragraph 27, what is the **most likely** reason that the soldiers cheered when Old Glory was raised over the capitol?
- A. The flag was in perfect condition.
 - B. The flag represented their country.
 - C. Captain Driver was joining the army.
 - D. Captain Driver was moving to the north.

- 33 Which word **best** describes William Driver's actions in the selection?

- A. modest
- B. peaceful
- C. patriotic
- D. mysterious

- 34 The information in the selection is **mainly** organized
- A. in order of importance.
 - B. in the order in which events happen.
 - C. by presenting a cause and then its effect.
 - D. by presenting a problem and then its solution.

- 35 Read the sentence from paragraph 21 in the box below.

Although house and yard were repeatedly searched by Confederate troops, no trace was found of the flag.

Which meaning of the word *trace* is used in the sentence?

- A. a sketch or outline
- B. a visible sign of something
- C. to follow a path or line exactly
- D. to follow the history of something

Question 36 is an open-response question.

- Read the question carefully.
- Explain your answer.
- Add supporting details.
- Double-check your work.

Write your answer to question 36 in the space provided in your Student Answer Booklet.

- 36** Based on the selection, explain
- a. why Old Glory was important to William Driver, and
 - b. how William Driver showed that the flag was important to him.
- Support your answer with important details from the selection.

This scene comes from a play based on Anne of Green Gables, a famous novel by Lucy Maud Montgomery. In this play, Anne is a young girl who has been adopted by Matthew and Marilla Cuthbert. They live on Prince Edward Island, in Canada, early in the 1900s. In the scene, Anne is excited about going to her first picnic—until something happens that may change her plans. Read the scene and answer the questions that follow.

Anne of Green Gables

Adapted by Jamie Turner

SCENE 4

TIME: *Several days later.*

SETTING: *Same. Brooch is on floor, under chair. Loose flowers and vase are on table.*

5 **AT RISE:** ANNE *sits with patchwork in lap, daydreaming.* MARILLA *enters.* ANNE *begins stitching vigorously.*

10 ANNE: I've been working steadily, Marilla, but it's ever so hard when the picnic is *this very afternoon*. I keep trying to imagine what it will be like.

15 MARILLA (*Looking around, puzzled*): Anne, have you seen my amethyst brooch? I thought I put it right here in my pin cushion, but I can't find it anywhere.

ANNE (*Nervously*): I — I saw it last night when you were at the Ladies Aid Society. It was in the pin cushion, as you said.

MARILLA (*Sternly*): Did you touch it?

20 ANNE (*Uncomfortably*): Yes. I pinned it on my dress for just a minute — only to see how it would look.

25 MARILLA (*Angrily*): You had no business touching something that didn't belong to you, Anne. Where did you put it?

30 ANNE: Oh, I put it right back. I didn't have it on but a minute, and I didn't think about it being wrong at the time, but I'll never do it again. That's one good thing about me. I never do the same naughty thing twice.

35 MARILLA (*Sternly*): You did not put it back, or else it would be here. You've taken it and put it somewhere else, Anne. Tell me the truth at once. Did you lose it?

ANNE (*Upset*): Oh, but I *did* put it back, Marilla. I'm perfectly certain I put it back!

40 MARILLA (*Angrily, her voice rising*): If you had put it back, it would be here, Anne. I believe you are telling me a falsehood. In fact, I know you are.

ANNE: Oh, but, Marilla . . .

45 MARILLA (*Harshly*): Don't say another word unless you are prepared to tell me where the brooch is. Go to your room and stay there until you are ready to confess. (*ANNE starts to exit downcast.*)

50 ANNE: The picnic is this afternoon, Marilla. You *will* let me out of my room for that, won't you? I *must* go to the picnic!

MARILLA: You'll go to no picnic nor anywhere else until you've confessed, Anne Shirley. Now, go! (ANNE *exits*)

MATTHEW (*Entering*): Where's Anne?

55 I wanted to show her the new geese down at the pond.

MARILLA (*Coldly*): She's in her room. The child has lost my amethyst brooch and is hiding the truth from me. She's

60 *lied* about it, Matthew.

MATTHEW: Well now, are you certain, Marilla? Mightn't you have forgotten where you put it?

MARILLA (*Angrily*): Matthew

65 Cuthbert, I remind you that I have kept the brooch safe for over fifty years, and I'm not likely to lose track of it now.

MATTHEW: Don't be too hasty to accuse Anne. I don't think she'd lie to you. (*Exits. MARILLA begins to arrange flowers in vase on table as ANNE enters.*)

ANNE: Marilla, I'm ready to confess.

MARILLA: Well, that was mighty quick. What do you have to say, Anne?

ANNE (*Speaking quickly as if reciting from memory*): I took the amethyst brooch, just as you said. I pinned it on my dress and then was overcome

80 with an irresistible temptation to take it down by the Lake of Shining Waters to pretend that I was an elegant lady named Cordelia Fitzgerald. But, alas, as I was leaning over the bridge to catch its purple reflection in the water, it fell

off and went down — down — down, and sank forevermore beneath the lake. Now, will you please punish me, Marilla, and have it over so that I can go to the picnic with nothing weighing on my mind?

MARILLA (*Staring at ANNE in anger*):

90 Anne, you must be the very wickedest girl I ever heard of to take something that wasn't yours and to lose it and then to lie about it and now to show no sign of sorrow whatever! Picnic, indeed! You'll go to no picnic! That will be your punishment, and it isn't half severe enough either for what you've done!

100 **ANNE** (*Sobbing*): Not go to the picnic! But, Marilla, that's why I confessed! Oh, Marilla, you promised! Think of the ice cream, Marilla! How can you deny me the ice cream and break my heart?

105 **MARILLA** (*Stonily*): You needn't plead, Anne. You are not going to the picnic, and that is final. (*ANNE runs to table and flings herself into a chair, sobbing and shrieking wildly.*) I believe the child is out of control. (*MARILLA walks around, wringing her hands. She suddenly catches sight of brooch under chair and picks it up with a startled cry.*) What can this mean? Here's my brooch, safe and sound! And I thought it was at the bottom of the lake! (*ANNE looks up.*) Anne, child, whatever did you mean by saying you took it and lost it?

120 **ANNE:** Well, you said you'd keep me in my room until I confessed, so I thought up an interesting confession so I could go to the picnic. But then you wouldn't let me go after all, so my confession was wasted.

MARILLA (*Trying to look stern, but finally laughing*): Anne, you do beat all! But I was wrong — I see that now. I shouldn't have doubted your word when you had never told me a lie before. Of course, you shouldn't have made up that story, but I drove you to it. So if you'll forgive me, I'll forgive you. Now, go upstairs and wash your face and get ready for the picnic.

ANNE: It isn't too late?

MARILLA: No, they'll just be getting started. You won't miss a thing — especially the ice cream. That's always last.

ANNE: (*Squealing happily*): Oh, Marilla! Five minutes ago I was in the valley of woe, but now I wouldn't change places with an angel! (*Exits*)

Anne of Green Gables © 1987 as adapted by Jamie Turner is reproduced with permission of PLAYS Magazine/Sterling Partners, Inc., P.O. Box 600160, Newton, MA 02460.

- 37 At the beginning of the scene, what information does the section titled “SETTING” provide?
- A. It tells how the stage should look.
 - B. It tells what has already happened.
 - C. It tells which characters are in the scene.
 - D. It tells where the characters should stand.

- 38 Why do lines 49 and 50 include words that are printed in italics?
- A. to show that the words should be whispered
 - B. to show that other words may be used instead
 - C. to show that the words are unspoken thoughts
 - D. to show that the words should be spoken with feeling

- 39 What is **most likely** true about Anne's confession in lines 77–90?
- A. She made it up so Marilla would let her go to the picnic.
 - B. She told the truth after she remembered what really happened.
 - C. She is trying to show that the amethyst brooch is not valuable.
 - D. She is trying to show Marilla that she did not mean to lose the brooch.
- 40 In lines 139–140, Anne refers to “the valley of woe.” What does the word *woe* mean?
- A. excitement
 - B. boredom
 - C. sadness
 - D. panic

**Grade 5 English Language Arts
Reading Comprehension
Spring 2007 Released Items:
Reporting Categories, Standards, and Correct Answers**

Item No.	Page No.	Reporting Category	Standard	Correct Answer (MC)*
1	82	<i>Reading and Literature</i>	10	D
2	82	<i>Reading and Literature</i>	13	C
3	82	<i>Reading and Literature</i>	13	A
4	82	<i>Reading and Literature</i>	13	C
5	83	<i>Reading and Literature</i>	8	D
6	83	<i>Reading and Literature</i>	13	A
7	83	<i>Language</i>	4	D
8	83	<i>Language</i>	4	A
9	84	<i>Reading and Literature</i>	13	
10	86	<i>Reading and Literature</i>	15	B
11	86	<i>Reading and Literature</i>	14	A
12	86	<i>Reading and Literature</i>	14	A
13	86	<i>Reading and Literature</i>	15	C
14	89	<i>Reading and Literature</i>	16	B
15	89	<i>Reading and Literature</i>	16	B
16	89	<i>Reading and Literature</i>	16	C
17	89	<i>Language</i>	4	B
18	90	<i>Reading and Literature</i>	16	
19	94	<i>Reading and Literature</i>	8	A
20	94	<i>Reading and Literature</i>	12	A
21	95	<i>Reading and Literature</i>	12	D
22	95	<i>Reading and Literature</i>	12	B
23	95	<i>Reading and Literature</i>	15	C
24	95	<i>Reading and Literature</i>	15	D
25	95	<i>Reading and Literature</i>	12	C
26	95	<i>Reading and Literature</i>	8	B
27	96	<i>Reading and Literature</i>	12	
28	100	<i>Reading and Literature</i>	13	A
29	100	<i>Reading and Literature</i>	13	A
30	101	<i>Reading and Literature</i>	13	A
31	101	<i>Reading and Literature</i>	13	D
32	101	<i>Reading and Literature</i>	13	B
33	101	<i>Reading and Literature</i>	8	C
34	102	<i>Reading and Literature</i>	13	B
35	102	<i>Language</i>	4	B
36	103	<i>Reading and Literature</i>	13	
37	106	<i>Reading and Literature</i>	17	A
38	106	<i>Reading and Literature</i>	17	D
39	107	<i>Reading and Literature</i>	17	A
40	107	<i>Language</i>	4	C

* Answers are provided here for multiple-choice items only. Sample responses and scoring guidelines for open-response items, which are indicated by shaded cells, will be posted to the Department's Web site later this year.

V. English Language Arts,
Reading Comprehension, Grade 6

Grade 6 English Language Arts Reading Comprehension Test

The spring 2007 grade 6 MCAS English Language Arts Reading Comprehension test was based on learning standards in the two content strands of the Massachusetts *English Language Arts Curriculum Framework* (2001) listed below. Page numbers for the learning standards appear in parentheses.

- Language (*Framework*, pages 19–26)
- Reading and Literature (*Framework*, pages 35–64)

The *English Language Arts Curriculum Framework* is available on the Department Web site at www.doe.mass.edu/frameworks/current.html.

In *Test Item Analysis Reports* and on the Subject Area Subscore pages of the MCAS *School Reports* and *District Reports*, ELA Reading Comprehension test results are reported under two MCAS reporting categories: **Language** and **Reading and Literature**, which are identical to the two *Framework* content strands listed above.

Test Sessions and Content Overview

The MCAS grade 6 ELA Reading Comprehension test included three separate test sessions. Each session included selected readings, followed by multiple-choice and open-response questions. Common reading passages and test items are shown on the following pages as they appeared in test booklets. Due to copyright restrictions, certain reading passages cannot be released to the public on the Web site. For further information, contact Student Assessment Services at 781-338-3625.

Reference Materials and Tools

The use of bilingual word-to-word dictionaries was allowed for current and former limited English proficient students only, during all three ELA Reading Comprehension test sessions. No other reference materials were allowed during any ELA Reading Comprehension test session.

Cross-Reference Information

The table at the conclusion of this chapter indicates each item's reporting category and the *Framework* general standard it assesses. The correct answers for multiple-choice questions are also displayed in the table.

English Language Arts

READING COMPREHENSION: SESSION 1

DIRECTIONS

This session contains three reading selections with sixteen multiple-choice questions and two open-response questions. Mark your answers to these questions in the spaces provided in your Student Answer Booklet.

Secret messages may seem like the stuff of spy novels, but “Invisible Inks” explains how you can create them in your own home! Read the selection and answer the questions that follow.

Invisible Inks

by Paul B. Janeczko

- 1 Just like many other code and cipher techniques and systems, the use of **invisible inks** can be traced to ancient times. There are records that the Greeks and the Romans used invisible inks that they extracted from plants and nuts. For example, Pliny the Elder, a Roman naturalist, used the “milk” of the thithymallus plant as an invisible ink. Since then, of course, invisible inks have become more sophisticated, even though they are not nearly as popular as they were during the Middle Ages and the Renaissance. Nevertheless, they have played a part in times of war.
- 2 There are two kinds of invisible inks. Some chemicals can be used as invisible inks, but they can be dangerous to use. These chemicals become invisible when they dry. Then they are “developed” with another chemical. This developing chemical is called a reagent, and could be something like iodine vapor or ammonia fumes. The other kind of invisible ink is organic, something easily obtained in nature. Believe it or not, onion juice and vinegar both make good invisible inks. These organic inks are developed by heat.
- 3 Before you start concocting your invisible inks, you need to realize that it may take a bit of experimenting before you get the ink so it works just right for you. So be patient as you work.
- 4 First of all, you will need some equipment. To write with your ink, you can use a quill (made by cutting the tip off of a feather), toothpicks, or a small brush, the kind you use for model painting or watercolors. While it takes some practice to write with a paintbrush, it does make a good “pen” for invisible ink because it will not leave indentations in the paper, a sure giveaway of your invisible secret. You might want to gather a few small jars to keep your ink in. Baby food jars or 35mm film canisters work well. As far as paper is concerned, you will want a fibrous paper,* like school composition paper, rather than glossy paper that won’t absorb the ink. All of this equipment can be stored in your field kit.
- 5 Once you have your equipment, you can start working on your inks. Here are a few liquids that make good invisible inks.
 - apple juice
 - citrus juice (lemon, orange)
 - onion juice (it may take a few tears to mash enough onion to get some ink, but it works well)

* *fibrous paper* — a soft, non-shiny paper

vinegar
sugar or honey
salt or Epsom salts
baking soda

- 6 As I said, you will need to experiment, particularly with the inks that require you to dissolve something in water. The juice inks may need to be diluted a bit if you can see their color on the paper.
- 7 There are other invisible inks. Cola drinks (not diet drinks because it is the sugar that makes the ink work) make good invisible inks if you can dilute them so the brown color doesn't show when you write your message. You can also use a styptic pencil, a sort of crayon that people dab on their skin to cover small nicks they get when they shave. Your mom or dad might have one that you can use.
- 8 When you write your message with one of these inks, it will become invisible when it dries. To develop the ink, you need to put some direct heat on the message. You can use a hair dryer, a small heater, an iron on a low setting, or a light bulb, about 150 watts or so. **Be careful when you use heat to develop your message.** You can get burned by any of these heat sources. If you use a light bulb or a heater, keep your message five or six inches away from the heat. Just give the heat time to work. If you iron your message, check constantly to make sure it isn't getting too hot.
- 9 Here are a couple of other invisible ink tricks:
1. You can use milk as an invisible ink. Instead of developing it with heat, rub some ashes across it and the message will appear.
 2. Have you ever noticed that when you press down very hard when you are writing with a pencil or pen, you leave indentations in the next sheet of paper? Well, that could be a sort of invisible message, although I would send the sheet that is two or three sheets beneath the one you wrote on. The indentations won't be as obvious. To "develop" such a message, rub the side of a pencil point across the message. You can also shine a light on the paper—slant the light and you should be able to see the message.
 3. A message written with starch will be invisible in daylight or electric light, but will become visible when placed under fluorescent light or ultraviolet light. Although fluorescent lights are common, you might need to see if a science teacher can help you find an ultraviolet light at school.
- 10 Once you have created your invisible inks, use them in a way that works best for you. One of the drawbacks of invisible ink is that you cannot send a lot of information because you need to find a way to hide all that information. In other words, if you are writing two pages of spy intelligence, you cannot simply send two blank pages. That will immediately draw close examination should it fall into unfriendly hands. Some spies wrote their invisible ink messages between the lines of a real letter. Others wrote the secret messages on the other side of the real letter. You could also put a dot of invisible ink over each letter in a newspaper article that, when taken in order, will spell out your message.

- 1 According to paragraph 2, which of the following is a reagent?
- A. cola drinks
 - B. onion juice
 - C. baking soda
 - D. iodine vapor
- 2 According to paragraph 2, what is the **main** advantage of using natural products to make invisible ink?
- A. Natural products may be safer than chemicals.
 - B. Natural products are easier to mix than chemicals.
 - C. Natural products dry more quickly than chemicals.
 - D. Natural products print more clearly than chemicals.
- 3 Based on paragraph 4, why is a paintbrush a good tool to use to write a message?
- A. It makes the ink dry faster.
 - B. It helps keep the message secret.
 - C. It makes the message seem like a picture.
 - D. It is easier to find than most other tools.
- 4 In paragraph 8, why is one sentence in **bold** print?
- A. It starts a new paragraph.
 - B. It is an important warning.
 - C. It defines an unfamiliar term.
 - D. It is something that a person said.

- 5 Based on paragraph 10, why should a message writer avoid sending blank pages that contain an invisible message?
- A. The blank pages will not heat well.
 - B. The blank pages will seem suspicious.
 - C. The blank pages will not show the ink.
 - D. The blank pages will be harder to send.

- 6 What are the “unfriendly hands” mentioned in paragraph 10?
- A. people who would try to send a secret message
 - B. people who would try to steal your ink formula
 - C. people who would expose your experiment to others
 - D. people who would read your message against your wishes

- 7 Read the sentence from paragraph 1 in the box below.

There are records that the Greeks and the Romans used invisible inks that they extracted from plants and nuts.

In the sentence, what does the word *extracted* **most likely** mean?

- A. ate
- B. grew
- C. colored
- D. removed

- 8 Read the sentence from paragraph 3 in the box below.

Before you start concocting your invisible inks, you need to realize that it may take a bit of experimenting before you get the ink so it works just right for you.

Based on the sentence, what is the **most likely** meaning of the word *concocting*?

- A. reading
- B. creating
- C. reviewing
- D. concealing

Question 9 is an open-response question.

- Read the question carefully.
- Explain your answer.
- Add supporting details.
- Double-check your work.

Write your answer to question 9 in the space provided in your Student Answer Booklet.

- 9 The instructions in “Invisible Inks” might be easier to follow if the selection used headings for different sections.
- a. Break the selection into **three** sections. Using the paragraph numbers, identify where each section will begin.
 - b. Write an appropriate heading for **each** of the three sections you identified in part (a). Explain why **each** heading is appropriate.

Support your answer with important details from the selection.

What is a boggart? Not many people know, but the Volniks—Robert and Maggie, and their children, Emily and Jessup—are about to find out that they have a boggart in their house. Read the selection to find out more about this interesting character. Then answer the questions that follow.

from **THE**
BOGGART

* * *

by Susan Cooper

- 1 THE BOGGART began his tricks gently. Over his centuries of mischief, he had learned not to rush things. The temptation was, of course, to dive into someone's life like a puppy running rampage in a tidy room; to turn everything upside down, all at once, in a great gleeful eruption of trickery. But that was like gobbling a whole bag of candy in five minutes. In the long run, there was much more fun to be had by taking your time.
- 2 So in a leisurely, temperate way, he started by hiding things. Robert left his razor on the bathroom window sill as usual after his morning shave, came back next morning and reached for it sleepily—and found it gone. He turned the whole bathroom upside down in a furious unsuccessful search, and only when he was frustrated, cross and late for an appointment did Maggie come across the razor quite by accident in the bedroom.
- 3 *Where did you find it?*
- 4 *On your bedside table.*
- 5 *What on earth was it doing there?*
- 6 *I guess you put it there, honey. . . .*
- 7 And the Boggart sat there listening, smiling. He would not play another trick on Robert until he had similarly removed Emily's algebra book from her bedroom desk to the kitchen vegetable rack, Maggie's favorite hat from the hallway coatrack to the upstairs linen cupboard, and Jessup's hockey stick to the basement laundry room. And in a careful patterning these tricks would be interspersed with others.
- 8 For instance, the Boggart enjoyed moving a chair or a lamp two feet away from its customary¹ place, so that it had to be moved back, usually by Robert, with muttered threats against the life of the once-a-week cleaning lady. If Emily tidied a bedroom drawer, the Boggart jumbled things up again. When Jessup organized all the books on his shelves alphabetically, by subject and author, the Boggart moved them into a different order overnight—using what he felt was an artistic pattern, with all the vowels lumped together in the middle of the alphabet. And when Maggie filled the sugar bowl with sugar one day, she found next morning that it was full of salt. The discovery was rather noisy, since Robert had just put a heaping spoonful into his breakfast coffee, stirred it briskly and taken a large gulp.

¹ *customary* — usual

9 The family reacted to all this in a satisfyingly predictable manner. At first each of them blamed himself or herself, for absent-mindedness. *How could I have been dumb enough to leave that there?* they would think, helplessly. But after a while they began privately to suspect that the absentmindedness belonged to someone else. *It was Maggie who moved my razor, but she's forgotten.* Slowly this became a mutual irritation, and as the Boggart's tricks became progressively more obvious, it grew into a conviction, in everyone's separate mind, that some other member of the family was deliberately playing practical jokes.

10 *Em, I wish you'd stop changing the books on my shelves. It's not funny.*

11 *I haven't touched your books.*

12 *You must have—who else would do it?*

13 The Boggart hugged himself as he listened to the spurts and flares of impatience. This was the first part of the game, the prelude. This beginning time was his private pleasure, the time in which only he knew what was really happening. Very soon they would all move to the next: to the moment when he would push them over the edge, into the delicious discovery of the real inventor of all the tricks and jokes. After that there would come a different pleasure; they would realize that they had a boggart in the house, and live with him according to the time-honored rules. He would keep them from becoming bored; they would, on the whole, enjoy him. And he would be part of the family, like a quirky² but valued relative.

...

14 So the Boggart looked ahead in happy anticipation, not knowing that he was living now in a world which no longer believed in boggarts, a world which had driven out the Old Things and buried the Wild Magic deep under layers of reason and time.

² *quirky* — strange, unusual

- 10 What does paragraph 1 **mostly** suggest about the Boggart?
- A. He has stolen candy as part of his tricks.
 - B. He has developed a method for his trickery.
 - C. He likes to play tricks quickly and then leave.
 - D. He likes to blame family pets for his trickery.
- 11 What do paragraphs 3–7 suggest?
- A. The family often argues about the Boggart.
 - B. The family is unaware that the Boggart is with them.
 - C. The Boggart enjoys bringing happiness to the family.
 - D. The Boggart helps the family when items are missing.
- 12 In paragraph 9, what does the phrase “mutual irritation” show about how the family members react to the Boggart’s tricks?
- A. They have become suspicious of each other.
 - B. They pretend that the tricks will stop happening.
 - C. They feel that the Boggart is becoming too dangerous.
 - D. They have become determined to get rid of the Boggart.
- 13 What does the Boggart’s reaction in paragraph 13 indicate about his mood?
- A. He is planning to move out of the house.
 - B. He is looking forward to what will occur next.
 - C. He is beginning to regret that he upset the family.
 - D. He is hoping to find someone to help him with his work.

T. S. Eliot's poem "The Old Gumbie Cat" describes a side of cats with which you may be familiar. But wait—there is more than meets the eye! Read the poem and answer the questions that follow.

THE OLD GUMBIE CAT

Students read a selection titled "The Old Gumbie Cat" and then answered questions 14 through 18 that follow on pages 121 and 122 of this document.

Due to copyright restrictions, the selection cannot be released to the public over the Internet. For more information, see the copyright citation below.

"The Old Gumbie Cat" from OLD POSSUM'S BOOK OF PRACTICAL CATS, copyright 1939 by T.S. Eliot and renewed 1967 by Esme Valerie Eliot, reprinted by permission of Harcourt, Inc. Illustration from OLD POSSUM'S BOOK OF PRACTICAL CATS by T. S. Eliot, copyright © 1982 by Edward Gorey, reproduced by permission of Harcourt, Inc.

Due to copyright restrictions, the selection that appeared on this page cannot be released to the public over the Internet. For more information, see the citation on the previous page.

- 14 What do lines 1–6 suggest about the cat during the day?
- A. She is lazy.
 - B. She is angry.
 - C. She is lonely.
 - D. She is annoyed.
- 15 In lines 7–14, how does the cat attempt to improve the manners of the mice?
- A. by keeping them busy
 - B. by chasing them around
 - C. by giving them a lecture
 - D. by teaching them to cook
- 16 Based on the poem, what is the cat's work?
- A. to sleep away hours in the sun
 - B. to create an organized household
 - C. to surprise the humans in the house
 - D. to make friends with other creatures
- 17 In the poem, which word **best** describes the speaker's attitude toward the cat?
- A. amused
 - B. hopeful
 - C. resentful
 - D. confused

Question 18 is an open-response question.

- Read the question carefully.
- Explain your answer.
- Add supporting details.
- Double-check your work.

Write your answer to question 18 in the space provided in your Student Answer Booklet.

- 18 Based on the poem, explain how the cat is different at night from how she is during the day. Support your answer with important details from the poem.

English Language Arts

READING COMPREHENSION: SESSION 2

DIRECTIONS

This session contains one reading selection with eight multiple-choice questions and one open-response question. Mark your answers to these questions in the spaces provided in your Student Answer Booklet.

Meg, Jo, Beth, and Amy March are well-known sisters from Louisa May Alcott's classic tale Little Women. They live in New England at the time of the Civil War with their mother, whom they call "Marmee." In this selection, Jo abandons Amy to go skating with her best friend, Laurence, or "Laurie." Their trip to the river meets with frightening results. Read the selection and answer the questions that follow.

from **Little
Women**

by Louisa May Alcott

Students read a selection titled *Little Women* and then answered questions 19 through 27 that follow on pages 125 and 126 of this document.

Due to copyright restrictions, the selection cannot be released to the public over the Internet. For more information, see the copyright citation below.

Reprinted with the permission of Aladdin Paperbacks, an imprint of Simon & Schuster Children's Publishing Division from LITTLE WOMEN by Louisa May Alcott.
Copyright © 1994 by Columbia Pictures Industries, Inc.

Due to copyright restrictions, the selection that appeared on this page cannot be released to the public over the Internet. For more information, see the citation on the previous page.

- 19 Based on the selection, what **most likely** occurred before Jo met Laurie to go skating?
- A. She had a quarrel with Amy.
 - B. She told Amy where to find them.
 - C. She tested the ice to see if it was safe.
 - D. She invited her family to go with them.
- 20 What is the “ear-splitting crack” in paragraph 10?
- A. the fence rail being pulled out
 - B. a tree limb falling near Laurie
 - C. a skate slapping against the ice
 - D. the ice breaking underneath Amy
- 21 What does the description in paragraph 11 indicate about Jo?
- A. She has tripped on the ice.
 - B. She has fallen into the water.
 - C. She is too frightened to react.
 - D. She is too far away to be heard.
- 22 In the selection, why does Jo feel responsible for what happens to Amy?
- A. Jo forgot Amy was not old enough to be on the river.
 - B. Jo challenged Amy to race across the center of the river.
 - C. Jo convinced Amy to skate on the weak part of the ice.
 - D. Jo was annoyed with Amy and pretended not to notice her.

- 23 Why does Meg speak to Jo with a “mock scolding voice” in paragraph 25?
- A. Meg wants Marmee to be proud of Jo.
 - B. Meg hopes that Marmee will punish Jo.
 - C. Meg is teasing Jo to make her feel better.
 - D. Meg wants Jo to admit she made a mistake.

- 24 What does the conversation between Jo and Amy in paragraphs 27–31 **best** suggest about them?
- A. They play tricks on one another, even though they sometimes get hurt.
 - B. They care about one another, even though they argued.
 - C. They try to get along for the good of the family.
 - D. They are still angry about their argument.

- 25 Which event is a major turning point in the selection?
- A. when Laurie sees the thin ice
 - B. when Jo hears a splash
 - C. when Jo crawls toward Amy
 - D. when Laurie carries Amy home

- 26 Read the sentence from paragraph 27 in the box below.

“I’m so sorry,” Jo said in a low voice, leaning close to her sister.

Which meaning of the word *low* is used in the sentence?

- A. quiet or soft
- B. nearly used up
- C. mean or coarse
- D. of lesser quality

Question 27 is an open-response question.

- **Read the question carefully.**
- **Explain your answer.**
- **Add supporting details.**
- **Double-check your work.**

Write your answer to question 27 in the space provided in your Student Answer Booklet.

- 27 Based on the selection, describe Jo’s character traits. Support your answer with important details from the selection.

English Language Arts

READING COMPREHENSION: SESSION 3

DIRECTIONS

This session contains two reading selections with twelve multiple-choice questions and one open-response question. Mark your answers to these questions in the spaces provided in your Student Answer Booklet.

Have you ever thought of starting your own business? “Getting Down to Business” explains some of the basic things you should know if you are thinking about starting a business to earn extra money. Read the article and answer the questions that follow.

Getting Down to Business

by Neale S. Godfrey

What’s in a Business?

- 1 You are part of the national economy. You use goods and services, so you are a consumer. But how can you be a producer? You can be by running or being part of a **business**. A business brings in money by selling goods or services. There are two basic types of businesses. A manufacturing business, like an in-line skate factory, makes and sells a product. In a service business, such as dry cleaning or home construction, someone does work in exchange for money or goods. What types of businesses have you been involved in?
- 3 Starting a business is hard work. It takes creativity, organizational skills, and courage. It means taking a **risk**. But it can be very rewarding if the business is a success. Many people are happy to run small businesses, and sometimes a small business can grow into a multimillion-dollar company!

Mind Your New Business

- 2 Have you ever started your own business? If so, you are an **entrepreneur**. An entrepreneur is someone who creates a business and often hires workers to help him or her. An entrepreneur makes the best use of natural resources as well as the talents and energies of workers to try to create a successful business.
- 4 Do you have an idea for a business? How are you going to get it up and running? First you’ll want to find out if your business has a chance of succeeding. One way to check is by doing a **market survey**. A market survey asks people questions about their likes and dislikes. It asks what goods or services people would use, and how much they’d be willing to pay for them. The answers people give to the survey help business people decide whether or not to move forward with their plans.

This Business Is for the Dogs!

- 5 Suppose you wanted to start a dog-walking service. You have the time and you like dogs. But you're not sure if people need this service in your area, and if they do, what specific needs they have. Here's a market survey you could use to find out.



MARKET SURVEY

- | | yes | no |
|---|--------------------------|--------------------------|
| • Do you have a dog? | <input type="checkbox"/> | <input type="checkbox"/> |
| • Do you walk your dog more than twice a day? | <input type="checkbox"/> | <input type="checkbox"/> |
| • Are you often too bone-tired to play with your dog? | <input type="checkbox"/> | <input type="checkbox"/> |
| • Does your dog need more exercise? | <input type="checkbox"/> | <input type="checkbox"/> |
| • Would you pay someone to exercise your dog? | <input type="checkbox"/> | <input type="checkbox"/> |
| • Would you pay for this service more than once a week? | <input type="checkbox"/> | <input type="checkbox"/> |
| • Would you be interested in weekend sessions? | <input type="checkbox"/> | <input type="checkbox"/> |
| • Do you know others who would be interested in this service? | <input type="checkbox"/> | <input type="checkbox"/> |

What's the Plan?

- 6 You started your dog-walking business. After a few weeks, and only a few customers, you panic. You haven't made back the money you spent! Look back. Did you make a business plan? A business plan tells what product or service will be sold and how it will be sold. It tells who the customers will be, how much it will cost to start the business, how much it will cost to run the business, and what the profits are expected to be.

Figuring It All Out

- 7 You'll also need a budget to work out the financial details of your business. You need to know how many dogs you are going to walk each week and how much to charge each customer. You need to consider how much you are going to spend on advertising. In addition to all these items are your **start-up costs**. Most of these are one-time purchases, such as dog leashes, made before you open your business.

Sharing the Spotlight

- 8 Suppose a friend decides to go into the dog-walking business in your neighborhood, too. You now have **competition**. When you start a business, you have to think about competition. Are there already businesses selling what you want to sell? Where are they? What are their products or services and their prices like? You may have to change your plan altogether.

Putting in the Time— and the Money

- 9 The market survey is done, the business plan is finished, and you've prepared a budget. But there's still more work to do! You need to contact new customers and make schedules. And you have to actually start walking some dogs! Starting a business is a big **investment**.

...

A Matter of Fact

You might think that a new ice-cream company might not be very successful with all the competition around. Well, with a \$12,000 investment (\$4,000 of it borrowed), Ben Cohen and Jerry Greenfield opened an ice-cream shop in a renovated gas station in Burlington, Vermont. In 1997, Ben & Jerry's ice cream was sold worldwide, and the company was making a profit of about \$6 million a year!

Keeping Tabs on Your Business

- 10 Once your business is off and running, you'll want to check to see how it's doing. You'll need to see if you are making a profit or experiencing a **loss**. If your expenses for walking the dogs are more than the money the business has taken in, you'll have a loss. If you have money left over after your business expenses are paid, you've made a profit and can consider yourself a successful entrepreneur!

Business Smarts

- 11 Why do some businesses succeed while others fail? Sometimes a business fails due to poor planning or poor management. Sometimes there are other factors. Many people would agree that the secret of success lies not in having the right answers, but rather in asking the right questions, such as *Do people want to buy what I want to sell? Is there any competition for my business? How can I make my business more attractive to customers? Do I have enough money to start the business? How long can I wait before I need to start making a profit?*

- 28 Based on the article, why is a dog-walking business called a “service”?
- A. It is an example of someone being a consumer.
 - B. It is an example of someone manufacturing a product.
 - C. It is an example of someone using organizational skills.
 - D. It is an example of someone doing work in exchange for money.

- 29 Based on paragraphs 4 and 5, a person who wanted to start a new business would **most likely** do a market survey with which group?
- A. people who might work for the business
 - B. people who have the same kind of business
 - C. people who might be customers of the business
 - D. people who have experience in starting a business

- 30 Based on paragraph 6, what is the **main** purpose of a business plan?
- A. to inform customers that a business is starting
 - B. to create an outline of how the business will run
 - C. to help a business owner create a work schedule
 - D. to keep track of the number of customers that a business has

- 31 Read the sentence from paragraph 7 in the box below.

You'll also need a budget to work out the financial details of your business.

- Based on paragraph 7, the term “financial details” **mainly** refers to
- A. money.
 - B. problems.
 - C. schedules.
 - D. advertising.

- 32 Based on paragraph 8, which of the following is a result of competition?
- A. having too much business to handle
 - B. having other people take business away
 - C. having people who want to work as partners
 - D. having too much money tied up in the business
- 33 Based on paragraph 10, which of the following is considered a profit?
- A. a business owner spending all of his time running his business
 - B. a business owner keeping good records of his business expenses
 - C. a business owner having more customers than a competitor has
 - D. a business owner making more money than he spends on his business
- 34 What is the **main** purpose of the information in the box titled “A Matter of Fact”?
- A. to give an example of a successful business that started small
 - B. to provide practical advice to people starting businesses
 - C. to show that restaurant businesses usually succeed
 - D. to explain how a family business is run
- 35 Which words **best** describe the author’s tone in the article?
- A. strict and serious
 - B. humorous and joking
 - C. friendly and informative
 - D. persuasive and powerful

Question 36 is an open-response question.

- Read the question carefully.
- Explain your answer.
- Add supporting details.
- Double-check your work.

Write your answer to question 36 in the space provided in your Student Answer Booklet.

- 36 Based on the article, explain why a market survey, business plan, and budget are important parts of starting a new business. Support your answer with important information from the article.

In 1938, the actor and director Orson Welles broadcast a radio play titled Invasion from Mars. The play was so lifelike and convincing that people all over the country panicked, thinking that the country was being invaded from outer space. This selection is part of that broadcast. Read the selection and answer the questions that follow.

from **Invasion from Mars**
by Howard Koch

Students read a selection titled *Invasion from Mars* and then answered questions 37 through 40 that follow on page 136 of this document.

Due to copyright restrictions, the selection cannot be released to the public over the Internet. For more information, see the copyright citation below.

Reprinted by permission of International Creative Management, Inc. Copyright © 1967 by Howard Koch.

Due to copyright restrictions, the selection that appeared on this page cannot be released to the public over the Internet. For more information, see the citation on the previous page.

Due to copyright restrictions, the selection that appeared on this page cannot be released to the public over the Internet. For more information, see the citation on page 133.

- 37 What is the **most likely** purpose of lines 1–6?
- A. to describe the setting
 - B. to give stage directions
 - C. to explain earlier events
 - D. to introduce the characters
- 38 In lines 25–33 of the selection, who are the VOICES?
- A. people describing the radio play
 - B. people pretending to witness the strange event
 - C. people listening to the fake broadcast
 - D. people recalling the extraterrestrial visit
- 39 In lines 47–49, why does Phillips move to “a new position”?
- A. to keep a safe distance from the creature
 - B. to be closer to the police and the professor
 - C. to be able to hear the reactions of the people
 - D. to make room for a reporter and a cameraman
- 40 In lines 76–78, what does Announcer Two indicate?
- A. He is controlling the eerie events at the field.
 - B. He is unsure of what has happened.
 - C. The newsman will soon return.
 - D. The event is fictional.

**Grade 6 English Language Arts
Reading Comprehension
Spring 2007 Released Items:
Reporting Categories, Standards, and Correct Answers**

Item No.	Page No.	Reporting Category	Standard	Correct Answer (MC)*
1	113	<i>Reading and Literature</i>	8	D
2	113	<i>Reading and Literature</i>	8	A
3	113	<i>Reading and Literature</i>	13	B
4	113	<i>Reading and Literature</i>	13	B
5	114	<i>Reading and Literature</i>	13	B
6	114	<i>Reading and Literature</i>	13	D
7	114	<i>Language</i>	4	D
8	114	<i>Language</i>	4	B
9	115	<i>Reading and Literature</i>	13	
10	118	<i>Reading and Literature</i>	8	B
11	118	<i>Reading and Literature</i>	12	B
12	118	<i>Language</i>	4	A
13	118	<i>Reading and Literature</i>	12	B
14	121	<i>Reading and Literature</i>	14	A
15	121	<i>Reading and Literature</i>	14	A
16	121	<i>Reading and Literature</i>	14	B
17	121	<i>Reading and Literature</i>	15	A
18	122	<i>Reading and Literature</i>	14	
19	125	<i>Reading and Literature</i>	8	A
20	125	<i>Reading and Literature</i>	15	D
21	125	<i>Reading and Literature</i>	12	C
22	125	<i>Reading and Literature</i>	12	D
23	126	<i>Reading and Literature</i>	12	C
24	126	<i>Reading and Literature</i>	12	B
25	126	<i>Reading and Literature</i>	12	B
26	126	<i>Language</i>	4	A
27	126	<i>Reading and Literature</i>	12	
28	130	<i>Reading and Literature</i>	8	D
29	130	<i>Reading and Literature</i>	13	C
30	130	<i>Reading and Literature</i>	13	B
31	130	<i>Language</i>	4	A
32	131	<i>Reading and Literature</i>	13	B
33	131	<i>Reading and Literature</i>	8	D
34	131	<i>Reading and Literature</i>	13	A
35	131	<i>Reading and Literature</i>	15	C
36	132	<i>Reading and Literature</i>	13	
37	136	<i>Reading and Literature</i>	17	A
38	136	<i>Reading and Literature</i>	17	B
39	136	<i>Reading and Literature</i>	8	A
40	136	<i>Reading and Literature</i>	17	B

* Answers are provided here for multiple-choice items only. Sample responses and scoring guidelines for open-response items, which are indicated by shaded cells, will be posted to the Department's Web site later this year.

VI. English Language Arts, Grade 7

A. Composition

B. Reading Comprehension

Grade 7 English Language Arts Test

Test Structure

The grade 7 MCAS English Language Arts test was presented in the following two parts:

- the ELA Composition test, which used a writing prompt to assess learning standards from the Massachusetts *English Language Arts Curriculum Framework's* **Composition** strand
- the ELA Reading Comprehension test, which used multiple-choice and open-response questions (items) to assess learning standards from the *Curriculum Framework's* **Language** and **Reading and Literature** strands

A. Composition

The spring 2007 grade 7 MCAS English Language Arts Composition test and Composition Make-Up test were based on learning standards in the **Composition** strand of the Massachusetts *English Language Arts Curriculum Framework* (2001). The learning standards for the Composition strand appear on pages 72–83 of the *Framework*, which is available on the Department Web site at www.doe.mass.edu/frameworks/current.html.

In *Test Item Analysis Reports* and on the Subject Area Subscore pages of the MCAS *School Reports* and *District Reports*, ELA Composition test results are reported under the reporting categories **Composition: Topic Development** and **Composition: Standard English Conventions**.

Test Sessions and Content Overview

The MCAS ELA Composition test included two separate test sessions, administered on the same day with a short break between sessions. During the first session, each student wrote an initial draft of a composition in response to the appropriate writing prompt on the next page. During the second session, each student revised his or her draft and submitted a final composition, which was scored in the areas of Topic Development and Standard English Conventions. The MCAS Writing Score Guide (Composition Grade 7) is available at www.doe.mass.edu/mcas/student/scoring7.doc.

Reference Materials and Tools

At least one English-language dictionary per classroom was provided for student use during ELA Composition test sessions. The use of bilingual dictionaries was allowed for current and former limited English proficient students only. No other reference materials or tools were allowed during either ELA Composition test session.

Cross-Reference Information

Framework general standards 19–22 are assessed by the ELA Composition.

English Language Arts Composition, Grade 7

Grade 7 Writing Prompt

WRITING PROMPT

Heroes have special qualities that people admire. Heroes give us examples of the courage and strength it takes to face difficult situations and challenges in life.

Think of someone who is your personal hero. In a well-developed composition, describe this person and explain two qualities you most admire about him or her.

Grade 7 Make-Up Writing Prompt

WRITING PROMPT

Your principal has decided to allow students to paint a mural on a wall of the school. The picture should show scenes, images, or stories that represent something positive about your school or community. The principal is looking for suggestions for the mural.

Think about what you would like to include in the mural. In a well-developed composition, describe your idea for the mural and what it reflects about your school or community.

B. Reading Comprehension

The spring 2007 grade 7 MCAS English Language Arts Reading Comprehension test was based on learning standards in the two content strands of the Massachusetts *English Language Arts Curriculum Framework* (2001) listed below. Specific learning standards for grade 7 are found in the *Supplement to the Massachusetts English Language Arts Curriculum Framework* (2004). Page numbers for the learning standards appear in parentheses.

- Language (*Framework*, pages 19–26; *Supplement*, page 14)
- Reading and Literature (*Framework*, pages 35–64; *Supplement*, pages 15–17)

The *English Language Arts Curriculum Framework* and *Supplement* are available on the Department Web site at www.doe.mass.edu/frameworks/current.html.

In *Test Item Analysis Reports* and on the Subject Area Subscore pages of the MCAS *School Reports* and *District Reports*, ELA Reading Comprehension test results are reported under two MCAS reporting categories: **Language** and **Reading and Literature**, which are identical to the two *Framework* content strands listed above.

Test Sessions and Content Overview

The MCAS grade 7 ELA Reading Comprehension test included three separate test sessions. Each session included selected readings, followed by multiple-choice and open-response questions. Common reading passages and test items are shown on the following pages as they appeared in test booklets. Due to copyright restrictions, certain reading passages cannot be released to the public on the Web site. For further information, contact Student Assessment Services at 781-338-3625.

Reference Materials and Tools

The use of bilingual word-to-word dictionaries was allowed for current and former limited English proficient students only, during all three ELA Reading Comprehension test sessions. No other reference materials were allowed during any ELA Reading Comprehension test session.

Cross-Reference Information

The table at the conclusion of this chapter indicates each item's reporting category and the *Framework* general standard it assesses. The correct answers for multiple-choice questions are also displayed in the table.

English Language Arts

READING COMPREHENSION: SESSION 1

DIRECTIONS

This session contains three reading selections with sixteen multiple-choice questions and two open-response questions. Mark your answers to these questions in the spaces provided in your Student Answer Booklet.

In “The Silent Treatment,” Sports Illustrated magazine columnist Rick Reilly writes about an extraordinary group of athletes. Read the article and answer the questions that follow.

The Silent Treatment

by Rick Reilly

Students read a selection titled “The Silent Treatment” and then answered questions 1 through 9 that follow on pages 145–147 of this document.

Due to copyright restrictions, the selection cannot be released to the public over the Internet. For more information, see the copyright citation below.

Reprinted courtesy of SPORTS ILLUSTRATED: “The Silent Treatment” by Rick Reilly, November 22, 2004. Copyright © 2004, Time Inc. All rights reserved.

Due to copyright restrictions, the selection that appeared on this page cannot be released to the public over the Internet. For more information, see the citation on the previous page.

- 1 In paragraph 3, why does the author write “WINDOWS SHATTER” in capital letters?
- A. to show how the players dance
 - B. to emphasize how loud the music is
 - C. to show how out of control the players are
 - D. to emphasize how much the author likes the music

- 2 Read the quote from paragraph 4 in the box below.

“But we’re not handicapped. We just can’t hear.”

Why is the quote important to the article?

- A. It explains why the author likes the team.
- B. It shows that the teams dislike each other.
- C. It shows how the coaches and players feel about their deafness.
- D. It explains how the coaches and parents communicate with the players.

- 3 Reread paragraph 5. What is the **main** idea of the paragraph?
- A. The CSDR coaches cheated in the game.
 - B. The CSDR coaches criticized their players.
 - C. The CSDR players used sounds to communicate.
 - D. The CSDR players performed well without needing to talk.

- 4 Based on paragraphs 8 and 9, which statement **best** summarizes the advantages of being a deaf football team?
- A. The team uses very simple plays.
 - B. The team cannot talk to opponents.
 - C. The team is able to influence the referees.
 - D. The team is unaffected by negative comments.

- 5 What is paragraph 12 **mainly** about?
- A. the kinds of plays the CSDR players use
 - B. the adjustments the CSDR players must make
 - C. the injuries that can occur to deaf football players
 - D. the way opponents have to play a deaf football team
- 6 Based on the author’s language in paragraph 12, what does he **most likely** assume about his readers?
- A. They are knowledgeable about football.
 - B. They are uninterested in the article.
 - C. They are uneducated.
 - D. They are deaf.

- 7 Read the statement from paragraph 17 in the box below.

“When you’re done with this story, you’ll be deaf too.”

- Keith Adams is making a joke about the loudness of the celebration, but there is a second meaning to the statement. What else might Adams be suggesting in the statement?
- A. The author will experience hearing loss.
 - B. The author will write more stories about the team.
 - C. The author will understand the players’ experience.
 - D. The author will continue to attend the team’s games.
- 8 According to his statement in paragraph 18, how does the author **mainly** feel about the CSDR players?
- A. He admires their success.
 - B. He thinks they are undisciplined.
 - C. He is amused by their behavior.
 - D. He is concerned about their future.

Question 9 is an open-response question.

- **Read the question carefully.**
- **Explain your answer.**
- **Add supporting details.**
- **Double-check your work.**

Write your answer to question 9 in the space provided in your Student Answer Booklet.

- 9** Describe the techniques the author uses to keep the reader interested in the article. Support your answer with important and specific details from the article.

In "A Rainy Morning," Ted Kooser turns an everyday observation into poetry. Read the poem and answer the questions that follow.

A Rainy Morning

Students read a selection titled "A Rainy Morning" and then answered questions 10 through 13 that follow on page 149 of this document.

Due to copyright restrictions, the selection cannot be released to the public over the Internet. For more information, see the copyright citation below.

Ted Kooser, "Rainy Morning" from *Delights and Shadows*. Copyright © 2004 by Ted Kooser. Used by permission of Copper Canyon Press, www.coppercanyonpress.org.

- 10 What is the **main** purpose of lines 1–3?
- A. to present an image
 - B. to provide an opinion
 - C. to introduce a conflict
 - D. to create a rhyme scheme
- 11 Which two things are being compared in the poem?
- A. the woman and the poet
 - B. the woman and the music
 - C. the woman and the pianist
 - D. the woman and the weather
- 12 In line 4, what is the purpose of using the word “You”?
- A. to encourage the reader to picture an action
 - B. to show that the poet is speaking to the woman
 - C. to show how much the poet admires the woman
 - D. to persuade the reader to agree with the poet’s views
- 13 Read lines 12 and 13 from the poem in the box below.

So expertly she plays the chords
of this difficult music she has mastered,

What is the “difficult music” the poet refers to?

- A. the rainy weather
- B. learning the piano
- C. living with a disability
- D. the silence of the morning

Even in an age of technology, humans have a special relationship with nature and can learn much from it. Read the following tall tale to see why Fred Jenness, a veteran woods guide, has so much respect for bears. Use information from the tall tale to answer the questions that follow.

Why I Never Shoot Bears

by Fred Jenness

- 1 Fred Jenness, veteran woods guide of Greenville, Maine, tells this tall tale and swears by all the Bibles in Piscataquis County that it is gospel truth:
- 2 “Do you know why I don’t kill bears?” he asked. “No! Well, it’s this way. Three years ago this June I was on a fishing trip up to Grand Lake. I had been out on the water pretty nearly all of one day and, getting tired, paddled back to camp. I hauled the canoe up on the sandy beach and started for the shack.
- 3 “When I got within about 100 feet of the place I saw the front door was open. I peeked in. There stood a big black bear just pulling the cork out of my molasses jug with his teeth. Out came the sticky syrup all over the floor. Bruin* lapped up some of it and then rubbed his right paw into the rest—smearred it all over.
- 4 “So I crept around behind the camp, stuck my head in the window and yelled. He shot through the door like a bullet and headed for the lake. I never saw such an odd gait on a bear before—sort of mixture of running and galloping. And all on three legs. He was holding up the paw daubed with molasses.
- 5 “From where I stood it looked as if the critter had sat down on the shore and was holding his sweetened paw up to the air. It was June and the air was full of flies, mosquitoes and black midges. I could see that they were swarming around that molasses foot. Soon it was covered with flies feasting on that stuff.
- 6 “Suddenly he waded out in the water and stood up. He was in to his shoulders. He placed the sweetened paw down close to the surface and the next thing I saw a fine trout jump clear of the water at those flies.
- 7 “Every time a fish leaped clear of the water, Bruin would give it a cuff that sent it ashore and far up the beach.
- 8 “Finally as he saw the pile of trout on the sand he seemed to think he had enough. He waded ashore lapping off the insects and I expected he would sit down and gobble every fish. I recalled that all I had caught that day was two small fish.
- 9 “Well, sir, he had a fine feed, and when he had eaten half a dozen fine big trout, he paused, looked over at the bushes where I was and actually laid the remaining fish in a row. Then he ambled off up the shore and oddly enough kept looking back over his shoulder.
- 10 “I walked down to the beach and true enough there were half a dozen wonderful trout. At the edge of the woods the bear stopped and was standing up. As loud as I could, I yelled, ‘Thanks, old man!’ Do you know he actually waved a paw at me and dove into the thicket. I honestly think he left me those fish to pay for my spilled molasses. No, *sir*, I never shoot bears.”

* *Bruin* — what Jenness named the big black bear

“Why I Never Shoot Bears”, from ANGLING IN AMERICA by Charles E. Goodspeed. Copyright, 1939 by Charles E. Goodspeed; copyright © renewed 1967 by George T. Goodspeed. Reprinted by permission of Houghton Mifflin Company. All rights reserved.

- 14 What in the tall tale might lead the reader to guess that Jennes is at least a little frightened by the bear?
- A. Jennes quietly opens the front door of the cabin.
 - B. Jennes is careful to stay away from the bear.
 - C. Jennes tells others to beware of the bear.
 - D. Jennes keeps his gun pointed at the bear.
- 15 According to the tall tale, what indicates that the bear had left the fish for Jennes?
- A. The bear left the fish in Jennes' shack.
 - B. The bear batted the fish onto the shore.
 - C. The bear waved his paw to Jennes.
 - D. The bear cleaned up the spilled molasses.
- 16 Based on the tall tale, which of the following suggests that Jennes regards the bear as a person rather than a wild animal?
- A. He invites the bear into his cabin.
 - B. He goes fishing with the bear.
 - C. He yells a thank-you to the bear.
 - D. He shares a meal with the bear.
- 17 Reread paragraphs 3 and 4. Which of the following phrases provides the **best** context clue for the word *daubed* as it is used in paragraph 4?
- A. lapped up
 - B. smeared it all over
 - C. headed for the lake
 - D. saw such an odd gait

Question 18 is an open-response question.

- **Read the question carefully.**
- **Explain your answer.**
- **Add supporting details.**
- **Double-check your work.**

Write your answer to question 18 in the space provided in your Student Answer Booklet.

- 18** Based on the tall tale, describe how the bear behaves like a human. Use relevant and specific information from the tall tale to support your answer.

English Language Arts

READING COMPREHENSION: SESSION 2

DIRECTIONS

This session contains one reading selection with eight multiple-choice questions and one open-response question. Mark your answers to these questions in the spaces provided in your Student Answer Booklet.

Travis and his family live on the Texas frontier in the mid-1800s. When Travis's father leaves on a cattle drive, his family adopts a stray dog they call "Old Yeller," both for the color of his coat and his loud bark. Read the excerpt from Old Yeller and answer the questions that follow.

from **OLD YELLER**
by Fred Gipson

1 THE man's name was Burn Sanderson. He was a young man who rode a good horse and was mighty nice and polite about taking his hat off to Mama when he dismounted in front of our cabin. He told Mama who he was. He said he was a newcomer to Salt Licks. He said that he'd come from down San Antonio way with a little bunch of cattle that he was grazing over in the Devil's River country. He said he couldn't afford to hire riders, so he'd brought along a couple of dogs to help him herd his cattle. One of these dogs, the best one, had disappeared. He'd inquired around about it at Salt Licks, and Bud Searcy had told him that we had the dog.

2 "A big yeller dog?" Mama asked, looking sober and worried.

3 "Yessum," the man said, then added with a grin. "And the worse egg sucker and camp robber you ever laid eyes on. Steal you blind, that old devil will; but there was never a better cow dog born."

4 Mama turned to me. "Son, call Old Yeller," she said.

5 I stood frozen in my tracks. I was so full of panic that I couldn't move or think.

6 "Go on, Son," Mama urged. "I think he and Little Arliss must be playing down about the creek somewhere."

7 "But Mama!" I gasped. "We can't do without Old Yeller. He's—"

8 "Travis!"

9 Mama's voice was too sharp. I knew I was whipped. I turned and went toward the creek, so mad at Bud Searcy that I couldn't see straight. Why couldn't he keep his blabber mouth shut?

10 "Come on up to the house," I told Little Arliss.

11 I guess the way I said it let him know that something real bad was happening. He didn't argue or stick out his tongue or anything. He just got out of the water and followed me back to the house and embarrassed Mama and the young man nearly to death because he came packing his clothes in one hand instead of wearing them.

12 I guess Burn Sanderson had gotten an idea of how much we thought of Old Yeller, or maybe Mama had told some things about the dog while I was gone to the creek. Anyhow, he acted uncomfortable about taking the dog off. "Now, Mrs. Coates," he said to Mama, "your man is gone, and you and the boys don't have much protection here. Bad as I need that old dog, I can make out without him until your man comes."

- 13 But Mama shook her head.
- 14 “No, Mr. Sanderson,” she said. “He’s your dog; and the longer we keep him, the harder it’ll be for us to give him up. Take him along. I can make the boys understand.”
- 15 The man tied his rope around Old Yeller’s neck and mounted his horse. That’s when Little Arliss caught onto what was happening. He threw a wall-eyed fit. He screamed and he hollered. He grabbed up a bunch of rocks and went to throwing them at Burn Sanderson. One hit Sanderson’s horse in the flank. The horse bogged his head and went to pitching and bawling and grunting. This excited Old Yeller. He chased after the horse, baying him at the top of his voice. And what with Mama running after Little Arliss, hollering for him to shut up and quit throwing those rocks, it was altogether the biggest and loudest commotion that had taken place around our cabin for a good long while.
- 16 When Burn Sanderson finished riding the pitch out of his scared horse, he hollered at Old Yeller. He told him he’d better hush up that racket before he got his brains beat out. Then he rode back toward us, wearing a wide grin.
- 17 His grin got wider as he saw how Mama and I were holding Little Arliss. We each had him by one wrist and were holding him clear off the ground. He couldn’t get at any more rocks to throw that way, but it sure didn’t keep him from dancing up and down in the air and screaming.
- 18 “Turn him loose,” Sanderson said with a big laugh. “He’s not going to throw any more rocks at me.”
- 19 He swung down from his saddle. He came and got Little Arliss and loved him up till he hushed screaming. Then he said: “Look, boy, do you really want that thieving old dog?”
- 20 He held Little Arliss off and stared him straight in the eyes, waiting for Arliss to answer. Little Arliss stared straight back at him and didn’t say a word.
- 21 “Well, do you?” he insisted.
- 22 Finally, Little Arliss nodded, then tucked his chin and looked away.
- 23 “All right,” Burn Sanderson said. “We’ll make a trade. Just between you and me. I’ll let you keep the old rascal, but you’ve got to do something for me.”
- 24 He waited till Little Arliss finally got up the nerve to ask what, then went on: “Well, it’s like this. I’ve hung around over there in that cow camp, eating my own cooking till I’m so starved out, I don’t hardly throw a shadow. Now, if you could talk your mama into feeding me a real jam-up meal of woman-cooked grub, I think it would be worth at least a one-eared yeller dog. Don’t you?”
- 25 I didn’t wait to hear any more. I ran off. I was so full of relief that I was about to pop. I knew that if I didn’t get out of sight in a hurry, this Burn Sanderson was going to catch me crying.

- 19 What is the **main** conflict of the excerpt?
- A. whether Travis will confront Bud Searcy
 - B. whether the family will be able to keep Old Yeller
 - C. whether Burn Sanderson will be mad at Little Arliss
 - D. whether Burn Sanderson will remain with the family
- 20 What does paragraph 3 **mainly** reveal about Burn Sanderson's feelings for Old Yeller?
- A. He fears Old Yeller.
 - B. He values Old Yeller.
 - C. He is angry at Old Yeller.
 - D. He feels sorry for Old Yeller.
- 21 In paragraph 9, why is Travis mad at Bud Searcy?
- A. Bud stole cattle from Travis's family.
 - B. Bud claimed Old Yeller had robbed his camp.
 - C. Bud told Burn Sanderson where Old Yeller was.
 - D. Bud told Burn Sanderson lies about Travis's family.
- 22 Why is Little Arliss's action in paragraph 15 important to the excerpt?
- A. It shows that Little Arliss is a misbehaving child.
 - B. It shows Little Arliss how dangerous it is to scare a horse.
 - C. It shows how happy Little Arliss is to see Burn Sanderson.
 - D. It shows Burn Sanderson how much Little Arliss loves the dog.

- 23 Why is Travis about to cry in paragraph 25?
- A. He is sad that Burn Sanderson is leaving.
 - B. He is sad that Little Arliss acted so badly.
 - C. He is happy that Mama is making a big meal.
 - D. He is happy that his family will keep Old Yeller.

- 24 At the end of the excerpt, why does Burn Sanderson **most likely** give Old Yeller to the Coates family?
- A. He no longer has any use for Old Yeller.
 - B. He dislikes the way Old Yeller raids his camp.
 - C. He realizes how much the family loves Old Yeller.
 - D. He is worried that the family is unsafe without Old Yeller.

- 25 Reread the sentences in paragraphs 7 and 8. What is the function of the dash in paragraph 7?
- A. to show that Travis is thinking
 - B. to show that Travis is speechless
 - C. to show that Mama silences Travis
 - D. to show that Mama sends Travis away

- 26 Read the sentences from paragraph 9 in the box below.

Mama’s voice was too sharp. I knew I was whipped.

- What does *whipped* mean in the sentence?
- A. hurt
 - B. sorry
 - C. defeated
 - D. understood

Question 27 is an open-response question.

- Read the question carefully.
- Explain your answer.
- Add supporting details.
- Double-check your work.

Write your answer to question 27 in the space provided in your Student Answer Booklet.

- 27 In the excerpt, Burn Sanderson's arrival affects Mama, Travis, and Little Arliss differently. Describe how **each** character reacts to Burn Sanderson's visit. Support your answer with important and specific information from the excerpt.

English Language Arts

READING COMPREHENSION: SESSION 3

DIRECTIONS

This session contains two reading selections with twelve multiple-choice questions and one open-response question. Mark your answers to these questions in the spaces provided in your Student Answer Booklet.

What can a community do when too many chemicals and metals appear in the air, land, and water, poisoning the environment? The state of Maine gets help from its residents. Read the following pamphlet to see how Maine educates its citizens regarding the dangers of mercury. Use information from the pamphlet to answer the questions that follow.

LET'S GET MERCURY OUT OF MAINE'S ENVIRONMENT

YOU CAN HELP!

1 What is mercury?

Mercury is a naturally occurring metal. It is liquid at room temperature, binds easily with other metals and conducts electricity well. Because of these properties, mercury has been used in many household, medical and industrial products.

2 Why is mercury of concern?

When mercury gets into our waterways, it changes. Through a natural chemical process it becomes methyl mercury, which is much more toxic. Methyl mercury in the food chain builds up in the tissue of fish and animals. It can cause weight loss, reproductive problems and early death. In humans, mercury is a neurotoxin. This means it slows fetal¹ and child development and impairs brain function. High exposure can cause tremors,² numbness of fingers and toes, loss of muscle control, memory loss, and kidney disease.

3 How does mercury get into Maine's environment?

Most mercury in the environment comes from human activities. Mercury enters the air in the emissions from coal burning power plants and waste incinerators. It enters our lakes, streams and rivers through rain and snow, through improper disposal of household products, and through wastewater discharges.

¹ *fetal* — relating to the unborn from the end of the eighth week after conception to birth

² *tremors* — trembling

4 How much is too much?

Mercury is toxic in very small quantities. Because mercury builds up in the food chain, even very small amounts of mercury in the water can make fish unsafe to eat and cause reproductive problems for wildlife such as loons. Also, mercury volatilizes³ at room temperature; this means that a small spill (1/2 teaspoon) indoors can create mercury levels in the air that are unsafe to breathe. One Maine school recently spent more than \$20,000 to clean up a spill from a single broken barometer so that students and staff would not breathe toxic mercury fumes!

5 Is mercury a problem in Maine?

Yes. Mercury has been found in bass, perch, pickerel, trout, salmon and eels as well as in our eagle and loon populations. Other fish eating animals are also at risk. Maine, like many other states, has fish consumption advisories that establish limits on the number of fish meals women and children can safely eat.

6 Where is mercury in my home?

Do a mercury search! Most commonly mercury is found in:

- Thermometers (fever, candy, fry, indoor/outdoor, oven)
- Thermostats (nonelectronic)
- Older paints
- Fluorescent lights
- Pilot light sensors in gas stoves, water heaters and dryers
- Barometers
- Button cell batteries
- Clothes irons with automatic or tilt shutoff
- Blood pressure cuffs
- Switches and relays in some chest freezers, older washing machines, sump and bilge pumps, and electric space heaters
- Silent light switches
- Topical disinfectants with Mercurochrome or Tincture of Merthiolate
- Antibacterial products with thimerosal or merbromin
- Vintage toys
- Chemistry sets
- Dental fillings
- LA Gear® athletic shoes made before 1997 with flashing lights
- Grandfather clock weights
- Antique mirrors

This list is not complete!
Check with the DEP Household
Hazardous Waste Program
if you have any questions.

³ volatilizes — evaporates

7 How can I prevent mercury pollution?

State and local governments are working together to develop a collection system for mercury containing products. Here's what you can do:

- ✓ Do a home audit and label mercury containing products.
- ✓ READ LABELS! Avoid buying products with mercury when substitutes are available.
- ✓ Ask your dentist for fillings that don't contain mercury amalgam.⁴
- ✓ Use fluorescent lights. Although they have a little mercury they save a lot of electricity, reducing reliance on coal burning power plants — a major source of mercury pollution.
- ✓ RECYCLE mercury containing products. Call your town office or the Maine DEP. . . for information about local collection events or the nearest household hazardous waste collection center.

8 What do I do if I break a mercury containing item?

Thermometers: Never use a vacuum to clean up a mercury spill! First, open windows to air out the room. If the thermometer breaks on a smooth surface, you can use two pieces of stiff paper to scoop all the beads into a sealable plastic container. If necessary, or on a carpet, use an eye dropper to capture the beads of mercury. Pick up any remaining beads of mercury with sticky tape. Put any contaminated portion of carpet and all cleanup materials in a plastic container. Take all materials to a household hazardous waste collection center or call Maine DEP. . .

For larger spills, call the Maine DEP. . . immediately!

Fluorescent bulbs: If a bulb breaks accidentally, scoop the pieces and powder into a sealable, plastic container. Air out the room. Wipe the area with a damp sponge and take all cleanup materials to a household hazardous waste collection center or call Maine DEP. . .

**This brochure was produced by the
Maine Department of
Environmental Protection
Household Hazardous Waste Program
17 State House Station
Augusta, ME 04333**

⁴ *mercury amalgam* — a mixture of mercury and silver used in dental fillings

- 28 How is the pamphlet organized?
- A. cause and effect
 - B. questions and answers
 - C. comparison and contrast
 - D. chronological order
- 29 According to the pamphlet, why are household mercury spills dangerous?
- A. Mercury is expensive to clean up.
 - B. Mercury can interfere with reproduction in fish.
 - C. Mercury droplets are a fire hazard.
 - D. Mercury vapors can pollute the atmosphere.
- 30 According to the pamphlet, what happens when mercury enters waterways?
- A. It spreads throughout the food chain.
 - B. It evaporates immediately.
 - C. It filters harmful chemical properties.
 - D. It affects plants but not animals.
- 31 In the pamphlet, what do the bullets in section 6 indicate?
- A. recycling instructions for household trash
 - B. household items with mercury
 - C. various uses for thermometers
 - D. steps for cleaning mercury spills

- 32 According to the pamphlet, how do fluorescent light bulbs lessen amounts of mercury in the environment?
- A. by shining brighter than regular light bulbs
 - B. by producing light that makes mercury spills easier to see
 - C. by using less electricity produced in coal burning plants
 - D. by burning longer than regular light bulbs
- 33 According to the pamphlet, who should be contacted for more information about household products containing mercury?
- A. scientists who study the environment
 - B. the Maine DEP Household Hazardous Waste Program
 - C. the nearest poison control center
 - D. the Maine Department of Education
- 34 Which section of the pamphlet provides instructions on how to dispose of mercury spills safely?
- A. **What is mercury?**
 - B. **How much is too much?**
 - C. **How can I prevent mercury pollution?**
 - D. **What do I do if I break a mercury containing item?**
- 35 The word *neurotoxin* in section 2 comes from the Greek word *neuro*, which means “nerve,” and the Latin word *toxicus*, which means “poison.” Which phrase **best** defines the word *neurotoxin*?
- A. a substance that damages nerve tissue
 - B. a medicine for people who have been poisoned
 - C. a person with nerve tissue damage
 - D. a doctor who studies poisons

Question 36 is an open-response question.

- Read the question carefully.
- Explain your answer.
- Add supporting details.
- Double-check your work.

Write your answer to question 36 in the space provided in your Student Answer Booklet.

- 36 Based on the pamphlet, explain what the citizens of Maine can do to help prevent mercury contamination. Use relevant and specific information from the pamphlet to support your answer.

“Blaming it on Adam” is a Nigerian folktale that retells the biblical story of Adam in an African setting. Read the folktale and answer the questions that follow.

Blaming it on Adam

- 1 Long ago there was a poor woodcutter named Iyapo who lived on the edge of the village in a small hut. Every morning he would get up early and go far away to the forest. In the forest, he would chop wood until the sun was at its highest point. Then he would carry all his wood down to the town and, after giving a few sticks to the tollkeeper at the gate, he would sell his wood.
- 2 He was always hungry but he had to sell his wood or he could not buy anything to eat.
- 3 “Wood, wood. Good wood. Who’ll buy some of my wood,” he would say as he walked up and down the streets. “It’s all the fault of Adam. Good wood for sale.” And so he sold some wood and bought food.
- 4 One day as Iyapo was selling his wood, the king heard him.
- 5 “Who is this person?” he asked his chief adviser. “And why does he say that it’s all the fault of Adam? If someone has wronged him then I should know about it.”
- 6 The chief adviser of the king asked all the other officers but none of them knew who he was or what he meant. So they took him to the king. He fell on the floor in respect.
- 7 “Now then, woodcutter, what is your name?” asked the king.
- 8 “Sire,” replied the frightened man, “my name is Iyapo.”
- 9 “Iyapo, that name means ‘many troubles’. But why are you blaming Adam?”
- 10 “I have heard that long ago Adam disobeyed God and ate the forbidden fruit. If he had not, we would all now be living in the Garden of Eden and I would never go hungry. That is why I say it is the fault of Adam.”
- 11 “I see,” said the king, looking thoughtfully at the woodcutter. “You are a hard worker yet you go hungry. It does not seem fair that you are suffering because of Adam’s mistake. I will help you.” The king called his chief adviser over and said to him, “Have Iyapo properly washed and dressed. Bring him to the palace and let him stay in one of the rooms there. Take his rags and wood away and let him have a new life.”
- 12 He then said to Iyapo, “From now on, you can call me brother. We will share everything and you can do anything you like except” – here he stared right into Iyapo’s eyes – “except, you may not open the green door at the end of the hall. That is the one thing that you must never do.”
- 13 “Oh, my king,” cried an ecstatic Iyapo, “what reason do I have to open the green door. I have food, clothes and shelter, what more could I want?”
- 14 And so the woodcutter led his new life of comfort. He never had to get up early or work hard, indeed he had forgotten what it used to be like to get up every day and chop wood. He was eating very well and was even starting to get fat.

- 15 He had quite forgotten all about the green door. Then one day he happened to pass by it, and as he did he remarked to himself, “That is the door which I must never open. Still, I wonder what is behind it that I, the king’s brother, am not allowed to find out.” And with a sigh he carried on.
- 16 During the next few days Iyapo seemed to be drawn towards the door all the time. Without being aware of trying, he found himself outside the door several times a day and each time he was getting more and more curious as to what was behind it. Sometimes without thinking about it, his hand actually started towards the handle but he managed to stop himself each time.
- 17 One day, the king said to Iyapo, “Brother, I have been called away to another town and I am afraid that I will not be back until much later in the day. I am entrusting the palace to you. Please make sure nothing happens.”
- 18 After the king left, the woodcutter started thinking, “The king has given me the responsibility of the palace. That is correct, after all am I or am I not the brother of the king. So surely I am responsible for the room behind the green door as well. I must be. I am going straight there now to find out what is hidden there.”
- 19 After checking that no one was looking, he put his ear against the door. He could not hear anything.
- 20 “I simply have to know what is in there. I will just open it a crack and close it again. The king will never find out.” And so he opened the door very slightly. The room was dark but after a while he could see that all that was in there were the old rags he used to wear and the wood he used to sell. Then suddenly, a mouse ran out the door.
- 21 “Oh no,” cried Iyapo, “the king was hiding a mouse in the room and now it has escaped. I must catch it.” And so he ran off in pursuit. As he ran, his shoes fell off. He started tripping over the bottom of his long, fancy robes and had to take them off. But still he could not catch the little mouse. His pampered life had made him fat and unfit and he was getting hot and out of breath. But he kept going – the king must not find out about his opening the door.
- 22 Suddenly the king was there. He was back early!
- 23 “And what are you doing, Iyapo?” boomed the king. “Why are you running around the palace without your clothes. Such behaviour does not become someone in your high position. Get up.”
- 24 But the poor Iyapo was prostrate on the floor sobbing. “I am sorry my king. I did not mean to let your mouse go.”
- 25 “What mouse?” asked the king. “I have no mouse.”
- 26 “The mouse in the room. You see I just opened the green door for a . . .”
- 27 “You opened the green door?”
- 28 “It was a mistake. I did not mean to, but my feet kept taking me there and I was curious and . . .”
- 29 “Iyapo, I am very disappointed in you. Opening the green door was the one thing I told you not to do.”

- 30 “I know sire, but I am the brother of the king and . . .”
- 31 “And now you want to be the king yourself,” shouted the king, angrily. “You are worse than Adam. You should have learned from his mistake.”
- 32 “I am sorry, my lord. It will never happen again, I promise. I am at your mercy, master. What do you wish of me?”
- 33 The king’s mood had changed and now he had tears in his eyes.
- 34 “Go back to the room,” he said sadly, “and take your rags and sticks. Return to the market and sell your wood.”
- 35 “Yes, sire.” The woodcutter could hardly speak.
- 36 “Just remember this, others cannot make you happy. It is up to you and your fate. Go and work hard and know that your poverty is not the fault of Adam or anyone else.”
- 37 And so Iyapo returned to the market and shouted, “Good wood. Wood here. Who wants to buy good wood?” But no longer did he say anything about Adam.

Reprinted by permission of HarperCollins Publishers Ltd © Ngangar Mbitu et al. 1997.

- 37 In the folktale, what causes Iyapo to be brought before the king?
- A. He is a dishonest businessman.
 - B. He has been critical of the king.
 - C. He is bothering some townspeople.
 - D. He has made a puzzling complaint.
- 38 According to paragraph 10, “Adam disobeyed God and ate the forbidden fruit.” Which of the following details from the folktale symbolizes the forbidden fruit?
- A. the forest
 - B. the village
 - C. the green door
 - D. the little mouse
- 39 How does Iyapo’s life change after he leaves the palace?
- A. He works harder than before.
 - B. He no longer respects the king.
 - C. He complains about how poor he is.
 - D. He no longer blames others for his problems.
- 40 Which of the following is the **best** definition of *drawn* as it is used in paragraph 16?
- A. pulled
 - B. breathed
 - C. sketched
 - D. concluded

Grade 7 English Language Arts
Reading Comprehension
Spring 2007 Released Items:
Reporting Categories, Standards, and Correct Answers

Item No.	Page No.	Reporting Category	Standard	Correct Answer (MC)*
1	145	<i>Reading and Literature</i>	15	B
2	145	<i>Reading and Literature</i>	13	C
3	145	<i>Reading and Literature</i>	13	D
4	145	<i>Reading and Literature</i>	13	D
5	146	<i>Reading and Literature</i>	13	B
6	146	<i>Reading and Literature</i>	15	A
7	146	<i>Reading and Literature</i>	13	C
8	146	<i>Reading and Literature</i>	13	A
9	147	<i>Reading and Literature</i>	15	
10	149	<i>Reading and Literature</i>	14	A
11	149	<i>Reading and Literature</i>	14	C
12	149	<i>Reading and Literature</i>	14	A
13	149	<i>Reading and Literature</i>	14	C
14	151	<i>Reading and Literature</i>	16	B
15	151	<i>Reading and Literature</i>	8	C
16	151	<i>Reading and Literature</i>	16	C
17	151	<i>Language</i>	4	B
18	152	<i>Reading and Literature</i>	16	
19	155	<i>Reading and Literature</i>	12	B
20	155	<i>Reading and Literature</i>	12	B
21	155	<i>Reading and Literature</i>	12	C
22	155	<i>Reading and Literature</i>	12	D
23	156	<i>Reading and Literature</i>	12	D
24	156	<i>Reading and Literature</i>	12	C
25	156	<i>Language</i>	5	C
26	156	<i>Language</i>	4	C
27	157	<i>Reading and Literature</i>	12	
28	161	<i>Reading and Literature</i>	13	B
29	161	<i>Reading and Literature</i>	8	D
30	161	<i>Reading and Literature</i>	8	A
31	161	<i>Reading and Literature</i>	13	B
32	162	<i>Reading and Literature</i>	8	C
33	162	<i>Reading and Literature</i>	13	B
34	162	<i>Reading and Literature</i>	13	D
35	162	<i>Language</i>	4	A
36	163	<i>Reading and Literature</i>	13	
37	167	<i>Reading and Literature</i>	16	D
38	167	<i>Reading and Literature</i>	16	C
39	167	<i>Reading and Literature</i>	16	D
40	167	<i>Language</i>	4	A

* Answers are provided here for multiple-choice items only. Sample responses and scoring guidelines for open-response items, which are indicated by shaded cells, will be posted to the Department's Web site later this year.

VII. English Language Arts, Reading Comprehension, Grade 8

Grade 8 English Language Arts

Reading Comprehension Test

The spring 2007 grade 8 MCAS English Language Arts Reading Comprehension test was based on learning standards in the two content strands of the Massachusetts *English Language Arts Curriculum Framework* (2001) listed below. Page numbers for the learning standards appear in parentheses.

- Language (*Framework*, pages 19–26)
- Reading and Literature (*Framework*, pages 35–64)

The *English Language Arts Curriculum Framework* is available on the Department Web site at www.doe.mass.edu/frameworks/current.html.

In *Test Item Analysis Reports* and on the Subject Area Subscore pages of the MCAS *School Reports* and *District Reports*, ELA Reading Comprehension test results are reported under two MCAS reporting categories: **Language** and **Reading and Literature**, which are identical to the two *Framework* content strands listed above.

Test Sessions and Content Overview

The MCAS grade 8 ELA Reading Comprehension test included three separate test sessions. Each session included selected readings, followed by multiple-choice and open-response questions. Common reading passages and test items are shown on the following pages as they appeared in test booklets. Due to copyright restrictions, certain reading passages cannot be released to the public on the Web site. For further information, contact Student Assessment Services at 781-338-3625.

Reference Materials and Tools

The use of bilingual word-to-word dictionaries was allowed for current and former limited English proficient students only, during all three ELA Reading Comprehension test sessions. No other reference materials were allowed during any ELA Reading Comprehension test session.

Cross-Reference Information

The table at the conclusion of this chapter indicates each item's reporting category and the *Framework* general standard it assesses. The correct answers for multiple-choice questions are also displayed in the table.

English Language Arts

READING COMPREHENSION: SESSION 1

DIRECTIONS

This session contains three reading selections with eighteen multiple-choice questions and two open-response questions. Mark your answers to these questions in the spaces provided in your Student Answer Booklet.

In A Dog Year, Jon Katz writes about the strong bond that develops between him and his two yellow Labrador retrievers, Julius and Stanley. Read the excerpt and answer the questions that follow.

from A DOG YEAR

by Jon Katz

1 We hardly had a bad moment, the three of us, so neatly did we fit together, interlocking pieces of the puzzle that is the varied partnership between humans and dogs.

2 Julius and Stanley embodied the noblest characteristics of their proud breed. They were handsome, loyal, utterly dependable, and affectionate. Julius came first. My daughter was young, and while there are different viewpoints about this, I personally don't believe there's a more rewarding moment for a parent than handing a happy, squirming, doe-eyed Lab puppy over to a small kid. I carry the look on her face in my memory, and while there are times when I can't remember what day of the week it is, I can always recall the wonder and joy in her eyes as if it had just happened.

3 Although I bought the dog with my daughter in mind, she was soon playing computer games and collecting garish-looking dolls, and I was out in the chill winter mornings cheering and exulting when a puzzled but earnest puppy took a dump outside.

4 Julius became mine, of course, the two of us bonding as if by Krazy Glue.

5 A year later, the breeder called and invited me to take a ride with my daughter to see the new litter. I was just looking, I assured my muttering and incredulous wife, Paula, who'd dragged Julius's old plastic dog crate out of the basement, ready to house its new resident, before I'd left the driveway.

6 My daughter and I returned with tiny, heart-melting Stanley. Julius was initially dubious about this new pest he had to contend with, but within a couple of days the two Labs loved each other as much as I loved them both, and they loved me and my family and, well, everybody who passed by.



7 It was a happy relationship from the first, and it only grew better, more comfortable. Both dogs were housebroken within days, settling happily into hours of rawhide-chewing.

8 Our lifestyles, as they say, meshed perfectly. Neither dog had much interest in running around.

9 Their great genius was doing nothing in particular with great style and dedication. Both disdained traditional canine tasks such as pursuing squirrels or rabbits, digging, or destroying property. Their chosen work was to reflect on the state of the world, lick neighborhood kids, and accompany me through midlife.

10 In the morning, neither dog moved a muscle until I did; then both slithered into bed for a family cuddle. After I was up and dressed, they sat quietly and attentively beneath the kitchen table, staring hypnotically at their food bowls, as if the power of their gazes would conjure up something tasty.

11 After breakfast, the early walk through our pleasant suburban neighborhood was leisurely, Julius and Stanley forensically sniffing along behind. Certain shrubs and rocks were always carefully inspected, each at a quite deliberate pace, the only area in which they would not compromise. Nothing could rush them; they'd go over every millimeter of a sapling's bark, undistractedly, until satisfied. A rabbit could hop right by—and sometimes did—without interrupting them.

12 For a half hour or so, the dogs proceeded at such stately paces and behaved so dependably that I was free to think about the coming day, what I wanted to write, how I wanted to write it. Our walks were tranquil, interrupted only by a stream of friends and admirers, from dog buddies to school-bus drivers.

13 Despite their historic roles as hunting dogs, however, they disdained rain and snow, and in inclement weather mastered a convenient hundred-yard dash to the nearest tree, then turned and hustled back inside.

14 Then it was time for work. I prepared a sandwich for each, taking two big rawhide chews and slathering a layer of peanut butter in between. Julius and Stanley carried the concoctions to the backyard and settled in for a deliberate gnaw, after which they were spent, and needed to refresh themselves with a long rest.

15 If the weather was fine, the dogs would spend much of the morning dozing in the yard. They might rouse themselves to bark at a passing dog. Mostly not.

16 On unpleasant days, they came into my study and offered themselves as footrests, both tucked underneath my desk, one on my left, one on my right.

17 I never had to provide much in the way of instruction. These guys knew how to relax. When the computer chimed as it booted up (I am an unswerving Macintosh man), the dogs dropped to the floor as if they'd been shot. They didn't move until they heard the monitor thunk off, at which point they'd rise (cautiously), ready for another stroll.

18 After a year or so, Julius and Stanley had achieved a Labrador state of grace, the ability to become an organic part of your life rather than an intrusion into it.

19 For a writer, having two such quiet and patient companions is a godsend. They warded off loneliness. They also kept me from a purely sedentary existence. After lunch, we'd rack up another mile or two at our usual unhurried pace.

- 20 Through the day, I supplied rawhide chews, pigs' ears, indeterminable and smelly dried bull parts, and a rain of treats and biscuits. It was ridiculously indulgent, of course, but I could not do enough for these boys, nor they for me. I tried to repay them for their love and unflagging loyalty, even though that was unnecessary and impossible.
- 21 They had their idiosyncracies. Julius was so unconcerned about wildlife (the sort his brethren traditionally retrieved) that he'd been known to nap inches from a rabbit's nest in the garden. And when Stanley wanted to chase a ball—which was much of the time—he would nip me in the butt to get me moving.
- 22 Once in a great while somebody would strew the garbage around the house, in the centuries-old tradition of Labs in Newfoundland who worked with fishermen, loved the cold, wet outdoors, and had to forage for food; they got to be pretty flexible about what they'd put in their stomachs. If I left them alone in the house, they collected odd articles of clothing—my wife's fuzzy bedroom slippers were a favorite—and slept with them.
- 23 It had been years since either dog had been on a leash or given me reason, despite the technicalities of local leash laws, to use one. Every kid in the neighborhood knew them and waved at them from bikes and car windows, through soccer-field fences. For many, they provided the first introduction to dogs, and they set a high standard. Over the years, many people told me that Julius or Stanley had inspired them to go out and get a dog.
- 24 When night fell, so did the Labs, settling on their cedar beds for a final rawhide snack, and descending into a deep, unmoving sleep.
- 25 After some years—Stanley was seven and Julius eight—we moved almost like a school of fish, the three of us veering in one direction, then another. We turned corners at the same time, sat in various parks and yards sharing lunch.
- 26 All the one ever asked was to live, play, and work alongside me. All the other one wanted besides that was the chance to swim in ponds once in a while and chase a ball a few times a day. They got what they wanted. So did I.

From *A DOG YEAR* by Jon Katz, copyright © 2002, 2003 by Jon Katz. Used by permission of Villard Books, a division of Random House, Inc. Photograph by Eric Etheridge.

- 1 Based on paragraphs 3 and 4, what caused the author to bond with Julius?
- A. He bought his daughter another dog.
 - B. His daughter was unhappy with Julius.
 - C. He became the main caregiver to Julius.
 - D. He had more experience with dogs than his wife did.
- 2 In paragraph 5, what does Paula imply by taking the old dog crate from the basement?
- A. The author will argue with her about the dog.
 - B. The author will be unhappy with the new puppy.
 - C. The author will not be able to handle two dogs.
 - D. The author will not be able to resist buying a new puppy.
- 3 What do paragraphs 19 and 20 **mainly** describe?
- A. what a writer's life is like
 - B. what the dogs ate for snacks
 - C. how different the dogs' personalities were
 - D. how the author benefited from the relationship
- 4 Paragraphs 21 and 22 describe the dogs' "idiosyncrasies." Which of the following best defines an *idiosyncrasy*?
- A. a household chore
 - B. a dangerous activity
 - C. a physical trait of a dog breed
 - D. a peculiar behavioral characteristic

5 According to paragraph 22, why would the dogs get into the garbage?

- A. They were poorly trained.
- B. They were left alone too often.
- C. They were responding to instinct.
- D. They were not given enough food.

6 According to the excerpt, what reputation did Julius and Stanley have in the author's neighborhood?

- A. They were considered nuisances.
- B. They were considered too inactive.
- C. They were considered to be ideal dogs.
- D. They were considered to be good guard dogs.

7 Read the sentence from paragraph 25 in the box below.

After some years—Stanley was seven and Julius eight—we moved almost like a school of fish, the three of us veering in one direction, then another.

What does the simile “like a school of fish” reveal about the author and his dogs?

- A. They had learned to vary their walks.
- B. They had become bored with each other.
- C. They had become easily distracted by things.
- D. They had developed an unspoken connection.

8 In paragraph 11, what does the term *forensically* suggest about how the dogs were sniffing?

- A. The dogs sniffed excitedly.
- B. The dogs sniffed thoroughly.
- C. The dogs sniffed very quickly.
- D. The dogs sniffed half-heartedly.

Question 9 is an open-response question.

- **Read the question carefully.**
- **Explain your answer.**
- **Add supporting details.**
- **Double-check your work.**

Write your answer to question 9 in the space provided in your Student Answer Booklet.

- 9** Describe how the author characterizes Julius and Stanley in the excerpt. Support your answer with relevant and specific information from the excerpt.

Ogden Nash has a way of making clever observations about life. P. B. (Percy Bysshe) Shelley was a famous nineteenth-century English poet. Read the poem and answer the questions that follow.

YOU AND ME AND P. B. SHELLEY

What is life? Life is stepping down a step or sitting in a
 chair,
 And it isn't there.
 Life is not having been told that the man has just waxed
 5 the floor,
 It is pulling doors marked PUSH and pushing doors marked
 PULL and not noticing notices which say PLEASE USE
 OTHER DOOR.
 Life is an Easter Parade
 10 In which you whisper, "No darling if it's a boy we'll name
 him after your father!" into the ear of an astonished
 stranger because the lady you thought was walking
 beside you has stopped to gaze into a window full of
 radishes and hot malted lemonade.
 15 It is when you diagnose a sore throat as an unprepared
 geography lesson and send your child weeping to
 school only to be returned an hour later covered with
 spots that are indubitably genuine,
 It is a concert with a trombone soloist filling in for Ye-
 20 hudi Menuhin.*
 Were it not for frustration and humiliation
 I suppose the human race would get ideas above its sta-
 tion.
 Somebody once described Shelley as a beautiful and inef-
 25 fective angel beating his luminous wings against the
 void in vain,
 Which is certainly describing with might and main,

 But probably means that we are all brothers under our
 pelts,
 30 And Shelley went around pulling doors marked PUSH and
 pushing doors marked PULL just like everybody else.

—Ogden Nash

* *Yehudi Menuhin* — a famous American violinist and conductor

- 10 In the poem, what does the poet use to define life?
- A. a popular fable
 - B. a dictionary definition
 - C. a quotation from another poem
 - D. a series of humorous comparisons
- 11 Which of the following phrases **best** summarizes the events described in lines 1–8?
- A. familiar nightmares
 - B. common practical jokes
 - C. life’s common frustrations
 - D. life’s dangerous experiences
- 12 Which of the following sentences **best** summarizes what is happening in lines 9–14?
- A. The speaker mistakenly speaks to a stranger.
 - B. The speaker asks a friend what to name his child.
 - C. The speaker ignores his wife and looks in a store window.
 - D. The speaker argues with his wife about naming their baby.
- 13 What is the speaker saying about Shelley in lines 24–31?
- A. Shelley was a better poet than most.
 - B. Shelley acted like an angel most of the time.
 - C. Shelley experienced many tragedies in his life.
 - D. Shelley experienced the same problems as everyone.
- 14 Which of the following definitions of *station* is used in lines 22–23?
- A. a social position or rank
 - B. a stopping place along a route
 - C. a place where one is assigned to stand
 - D. a place from which a service is provided

The epic of Gilgamesh dates from 1700 BC but was only discovered in AD 1853, buried in the ruins of Nineveh, in present-day Iraq. Written on clay tablets, it relates the life and adventures of a famous king, Gilgamesh, and his best friend, Enkidu. Read the excerpt from Gilgamesh and answer the questions that follow.

from GILGAMESH
BOOK III

Students read a selection titled *Gilgamesh* and then answered questions 15 through 20 that follow on pages 182 and 183 of this document.

Due to copyright restrictions, the selection cannot be released to the public over the Internet. For more information, see the copyright citation below.

Reprinted with the permission of The Free Press, a Division of Simon & Schuster Adult Publishing Group from GILGAMESH: A New English Version by Stephen Mitchell. Copyright © 2004 Stephen Mitchell. All Rights Reserved.

Due to copyright restrictions, the selection that appeared on this page cannot be released to the public over the Internet. For more information, see the citation on the previous page.

Due to copyright restrictions, the selection that appeared on this page cannot be released to the public over the Internet. For more information, see the citation on page 179.

- 15 Which of the following elements of an epic is established in stanza 1 of the excerpt?
- A. the hero's task
 - B. the story's moral
 - C. the gods' character
 - D. the hero's love interest
- 16 What is the **main** purpose of Gilgamesh's speech in stanza 6?
- A. to compare men with the gods
 - B. to describe Humbaba's childhood
 - C. to describe how dangerous the forest is
 - D. to persuade Enkidu to accompany him
- 17 In stanza 6, why is Gilgamesh unafraid of confronting Humbaba?
- A. He will be with Enkidu.
 - B. He will be protected by the gods.
 - C. He knows that Humbaba is cowardly.
 - D. He understands that all people must die.

- 18 In the excerpt, what does Gilgamesh **most** hope will result from killing Humbaba?
- A. glory for himself
 - B. safety for his people
 - C. the favor of the gods
 - D. the respect of his friend

- 19 Read stanza 12 of the excerpt in the box below.

Enkidu listened gravely. He stood silent there for a long time. At last he nodded. Gilgamesh took his hand.

- What is suggested by the stanza?
- A. The men are saying goodbye.
 - B. Enkidu will go with Gilgamesh.
 - C. Gilgamesh is frustrated with Enkidu.
 - D. The men agree with the elders' advice.

Question 20 is an open-response question.

- **Read the question carefully.**
- **Explain your answer.**
- **Add supporting details.**
- **Double-check your work.**

Write your answer to question 20 in the space provided in your Student Answer Booklet.

- 20** Describe the conflict between Gilgamesh and Enkidu in the excerpt. Support your answer with relevant and specific information from the excerpt.

English Language Arts

READING COMPREHENSION: SESSION 2

DIRECTIONS

This session contains one reading selection with seven multiple-choice questions and one open-response question. Mark your answers to these questions in the spaces provided in your Student Answer Booklet.

In this excerpt, the narrator talks about a family memory. The Abenaki are American Indian people from New England and eastern Canada. Read the excerpt and answer the questions that follow.

CLIMBING THE LADDER

by Joseph Bruchac

- 1 As I look at that photograph and the smile on my grandfather's face, I think of the day I climbed the ladder. The story of me and the ladder is a tale both my grandfather and grandmother told me so often that I feel my memory of it is completely my own.
- 2 My grandfather was never afraid of heights. I've heard it said, and even read it in a place or two, that the Indian people of the Northeast are born without a fear of high places, that it is something genetic. I don't know if I believe that. It might be more that non-Indians are taught, as children, to be afraid of so many things that might hurt them—sharp objects, fire, high places, wild animals, the woods, strangers—that they grow up scared of everything. Do this and don't do that.
- 3 There was little of "do this and don't do that" in my grandfather's growing up, from what he told me. If he stuck his hand in the fire, that fire would burn him. No need for any adult to teach a kid that. If he climbed a tree and fell out, then he'd learn on his own that high places were dangerous. Neither his father nor his mother ever struck him—or even shouted at him.
- 4 . . . In the Abenaki way you learn better by doing than by being told. People are allowed to make their own mistakes. In the Abenaki way, you never strike a child, for fear that a blow might break their spirit. It might take away their self-respect, make them sad and fearful, and teach them that it is right for those who are big to bully those who are small.
- 5 The self-respect that was nurtured by his parents was so much a part of my grandfather's upbringing, he would never allow anyone to tell him what to do—unless he felt in his heart that it was right for him to do it. His mother died when he was thirteen and his father remarried—marrying his wife's widowed sister. My grandfather left his father's home shortly after that, never to return. I once asked him why.
- 6 "I didn't like her," he said, referring to his stepmother.
- 7 "Why not, Grampa?"
- 8 "She jes' yelled at me," he said. "I told my father, if he ever needed help, all he had to do was ask and I'd do it. But I wasn't a-going to stay under the same roof with her."
- 9 And that was it. That same year he left home and went off to work. He worked first at the store of Seneca Smith and then as a logger in the woods. He was on his own, but not afraid to be there. That was just how he was with heights too.

- 10 There was this thing my grandfather used to do every now and then, even when he was eighty years old. He called it “checking the peak.” He would go outside, look up at the roof of the house, and then declare, “I got to check the peak.” He’d take the wooden extension ladder and place it against the south side of the house. That house rises up three stories and more. When you stand on the peak you can see Saratoga Lake, ten miles to the south, and the hills of Vermont, thirty miles to the east. That was what my grandfather would do. He would climb that ladder and then make his way up the steep metal roof to stand on the very peak, to walk along it with easy, balanced steps, and then lean against the brick chimney and look out. Checking the peak.
- 11 The autumn day I remember, the day my grandparents lodged so firmly into my memory by telling and retelling the story, my grandfather decided to check the peak. It was October and I had just turned three. . . .
- 12 My face intent and serious, I followed my grandfather as he took out the ladder that day. I was quiet. I had already learned that it was easier to go unnoticed when one was quiet. When my parents lived in this house, it had usually been safest for me to be unnoticed. My grandfather set the base of the ladder firmly onto the ground and stomped on the bottom rung with his foot. He shook it to make sure it was steady, and then went up. Even though he was over sixty, he moved as quick as a cat up that ladder. I watched every step to see how he did it. He reached the top and then went up the silver-painted roof to stand on the peak and look out, shading his dark-browed eyes with his left hand. Then he heard a sound. It was a little voice saying “Aaah!”
- 13 He turned and looked down to see me at the very top of the ladder, swaying back and forth a bit and looking out. There was so much to see from up there! I was happy.
- 14 “Aaah,” I said again.
- 15 Another man might have yelled then or tried to grab me, but that was not my grandfather’s way. Instead, in his calm, soft voice he just said, “Well, I’ll be! Forgot my hammer. Got to go back down and get it. Sonny, you go first.”
- 16 I started down the ladder, but before I had gone more than a rung or two, my grandfather was there with me. He was climbing down the ladder with his hands a rung above me and his feet two rungs below me. I had heard my grandmother talking to him so often about how he was “getting on in years” and needed “to be more careful.” She was worried about him doing such things as climbing high ladders. I remembered that, and so I guessed that he must have wanted my help when he came down. I took it slow and was really careful.
- 17 But when we got to the bottom the strangest thing happened. Grampa forgot all about the hammer he’d needed. Instead, he just took that ladder, laid it down on the ground, and then sat there himself with one arm around me and one hand patting his chest. I put my hand on his shoulder to reassure him. I didn’t know what “getting on in years” was, but I figured that must have been the reason for him being so upset. Whatever it was, I hoped he would recover from it soon.

- 21 According to the narrator, what is the **main** effect of the “do this and don’t do that” method of parenting?
- A. It makes children afraid of too many things.
 - B. It makes children afraid of meeting new people.
 - C. It makes children afraid of heights.
 - D. It makes children afraid of their parents.
- 22 Based on the first sentence in paragraph 5, what word **best** describes the narrator’s grandfather?
- A. independent
 - B. rebellious
 - C. selfish
 - D. solitary
- 23 Which sentence from the excerpt **best** explains why the narrator reaches the top of the ladder without being seen?
- A. “My face intent and serious, I followed my grandfather as he took out the ladder that day.”
 - B. “I had already learned that it was easier to go unnoticed when one was quiet.”
 - C. “Even though he was over sixty, he moved as quick as a cat up that ladder.”
 - D. “I watched every step to see how he did it.”
- 24 Based on the excerpt, why does the boy say “Aaah” in paragraphs 12 and 14?
- A. He is trying to get his grandfather’s attention.
 - B. He is delighted at the view from the roof.
 - C. He is suddenly nervous about being up so high.
 - D. He is surprised by how much he likes the ladder.

- 25 Which of the following **best** describes the grandfather in paragraph 17?
- A. amused
 - B. annoyed
 - C. puzzled
 - D. relieved
- 26 Based on the excerpt, how does the narrator view his grandfather?
- A. with respect and admiration
 - B. with fear and distrust
 - C. with concern and pity
 - D. with shame and anger

- 27 What does the word *lodged* mean as it is used in the first sentence of paragraph 11?
- A. lost
 - B. stuck
 - C. haunted
 - D. imagined

Question 28 is an open-response question.

- **Read the question carefully.**
- **Explain your answer.**
- **Add supporting details.**
- **Double-check your work.**

Write your answer to question 28 in the space provided in your Student Answer Booklet.

- 28 In the excerpt, the narrator describes the Abenaki way of doing things. Explain how the events in the excerpt reflect the Abenaki way. Use relevant and specific information from the excerpt to support your answer.

English Language Arts

READING COMPREHENSION: SESSION 3

DIRECTIONS

This session contains two reading selections with eleven multiple-choice questions and one open-response question. Mark your answers to these questions in the spaces provided in your Student Answer Booklet.

Garbage workers in New York City have developed a fascinating vocabulary to describe their work. This article reveals the origins of such terms as “disco rice,” “mongo,” and other colorful expressions. Read the article and answer the questions that follow.

Disco Rice, and Other Trash Talk

In New York, Picking Up the Garbage Means Picking Up the Lingo

by Ian Urbina

- 1 Trash stinks, and as the summer heats up and the rain casts a musty net over the air, it stinks more. So the garbage workers step into the spotlight. The summer is the sanitation workers’ moment to be heroes, like firefighters at a four-alarm or police officers at a murder scene. The garbage crews clear the air and make way for the next day’s mass consumption.
- 2 But listen closely. Safeguarding New York City from olfactory assault are its 6,200 sanitation workers. You may notice them in their sweaty haul from curb to truck, but understanding what they say is a different matter. That’s because the insular subculture of this thankless job requires a lingo almost as funky as the work itself.
- 3 The hopper is the back of the truck. Baling is when the truck compacts trash in its belly. Workers often refer to themselves as trash hounds or sanit men. Lazy workers walk backward. Speedy workers are called runners. The trucks are called white elephants, for their size, smell and expense. The amount of trash they consume is measured by indentations on the side, called ribs.
- 4 The slang has been created over generations, an argot so encompassing that it is actually the focus of academic study. It makes disgusting items not so disgusting. It honors retired supervisors. For no other reason than it is summer, and it is hot outside, and the garbage men are breaking their backs carting away the city’s smelly trash, here is a guide to this other language of New York.
- 5 “If an outsider steps into a sanitation garage in the city, there is a good chance he will have no clue what’s being said,” said Robin Nagle, an anthropology professor at New York University, who has studied the culture of sanitation since 1995. “It’s a fairly closed community.”
- 6 Some terms have crossed over into pop culture. Art exhibits around the country now feature “mongo,” New York sanitation slang for salvaged garbage. Other expressions are less than enticing. “Disco rice” refers to maggots. . . .
- 7 Perhaps it should come as no surprise that a vibrant lexicon has emerged from the oldest uniformed municipal sanitation force in the nation, handling more trash than any other, in a city known for its clever turn of phrase.

8 Much of the jargon comes from workplace tasks. Senior employees do “collections,” which means residential pickup at about \$35 extra per day. The fortunate who get the “tissue” do lighter duty, such as desk work. The luckiest “get Schranked,” named for Bob Schrank, a departmental official who in the 1980’s established the policy that a worker with collections seniority who does not get to ride the truck still earns higher pay for tasks like desk work and “running the baskets.”

**In the sanitation
business, slang is passed
down through the years.**

9 Newcomers usually “run the baskets,” emptying city trash cans on street corners. Worse still is the job of draining “hopper juice,” the dreaded bile that collects in the belly of the beast.

10 “Swinging a load” is when corrupt crews weigh down their truck with leftover trash from the previous day or hidden objects like cinder blocks or roof-welded steel plates to trick the scales and get credit for a larger haul.

11 The reason for the proliferation of sanitation slang remains unclear. “The irony is that the very stigma that makes these workers invisible is what gives rise to their gallows humor and the wit of their overall culture,” said Mierle Laderman Ukeles, who has been the artist in residence for the city’s Department of Sanitation since 1977. “People isolated on the fringe always create their own mores and their own lingo.”

12 Grant Barrett, project director for the Historical Dictionary of American Slang, the third volume of which will be published by Oxford University Press in early 2006, offered a similar explanation. “Much of professional jargon is tongue in cheek,” he said, explaining that it lends levity to the drudgery of daily labor.

13 Sanitation policymakers also contribute to the catchy argot, as with “nimby,” or not in my back yard. Carmen J. Cognetta, counsel to the City Council’s sanitation and solid waste committee, said that “nimby used to be the key term in the department.”

14 “But now,” he added, “the Sanitation Department describes the mood as ‘banana,’ which means ‘build absolutely nothing anywhere near anyone.’ And sometimes they say things in the city are verging on ‘nope,’ which is ‘not on planet earth.’”

15 The existence of sanitation jargon is not new. Mr. Barrett of Oxford University Press said some terms originated in the 1940’s and 50’s. A few examples: honey boat: a garbage scow or barge (1941); g-man: garbage man, soldier handling garbage duties, usually associated with the military (1941); airmail: trash thrown from high windows (1952).

16 But Frank O’Keefe, who has been with the department nearly two decades, is quick to point out that workers — not administrators — produce the best material.

17 “For administrators, we don’t pick up trash, we collect it,” Mr. O’Keefe said. “We don’t dump it in Jersey, we export it. There’s never a pile on the corner of Fifth Avenue, there’s a situation on Fifth Avenue. The guys on the back of the truck are the ones who know what they’re doing and who have the knack.”

18 Ms. Ukeles pointed out that aside from handling snow removal, the sanitation workers haul about 11,000 tons of garbage a day. “The workers hold two things in common: the language of their trade and the sense of being taken for granted,” she said.

19 This self-perception may explain sanitation workers comparing themselves with the city’s police officers and firefighters. “Sanitation workers always say you can go your whole life without ever needing a firefighter,” Ms. Nagle, the anthropology professor, said. “If you’re lucky, the same goes for calling the cops. But you need sanitation workers every single day.”

- 20 Official mottos from each department echo others. “New York’s finest” refers to the city’s police. The firefighters are “New York’s bravest.” The sanitation force goes by “New York’s strongest.”
- 21 While admitting that their job does not require facing off with knife-wielding criminals or racing into burning buildings, sanitation workers are quick to point out that their profession is consistently ranked among

the top 10 most dangerous jobs, according to the federal Bureau of Labor Statistics. The danger, Ms. Nagle said, comes mostly from car swipes, machinery injuries, rat bites and debris flying from the hopper.

- 22 “We’ve got a saying when people take us for granted,” said Ronnie Cohen, a worker from Manhattan. “We just tell them that we can deliver instead if that’s their preference.”

Copyright © 2004 by The New York Times Co. Reprinted with permission.

- 29 In paragraph 1, what does the author’s comparison of garbage crews to firefighters and police officers suggest?
- A. that garbage workers should be paid more
 - B. that garbage workers have dangerous jobs
 - C. that garbage workers are important to the city
 - D. that garbage workers often move on to other jobs

- 30 In paragraph 3, how does the author establish the focus of the article?
- A. He explains how garbage is collected.
 - B. He compares garbage collection to other work.
 - C. He introduces technical details about garbage trucks.
 - D. He gives examples of language used by garbage workers.

- 31 According to paragraph 4, what is one of the **main** reasons that garbage workers' slang has evolved over the years?
- A. It has been studied by language experts.
 - B. It makes an unpleasant job more tolerable.
 - C. It describes a highly technical field of work.
 - D. It helps garbage workers to communicate effectively.

- 32 Read the sentence from paragraph 9 in the box below.

Worse still is the job of draining "hopper juice," the dreaded bile that collects in the belly of the beast.

- In the sentence, why does the author describe "hopper juice" as "the dreaded bile"?
- A. to explain why draining hopper juice is difficult to do
 - B. to emphasize the unpleasantness of draining hopper juice
 - C. to exaggerate the effort involved in draining hopper juice
 - D. to compare draining hopper juice to a medical emergency

- 33 Which of the following can **most reasonably** be concluded from paragraph 10?
- A. Sanitation trucks are difficult to load.
 - B. Many sanitation workers are dishonest.
 - C. Sanitation truck earnings are based on weight.
 - D. Sanitation workers sometimes haul unusual objects.

- 34 Based on the article, how do sanitation workers feel they are viewed by the general public?
- A. as doing a dangerous job
 - B. as often acting dishonestly
 - C. as less valued than other city workers
 - D. as similar to firefighters and the police

- 35 Read the text from paragraph 7 in the box below.

Perhaps it should come as no surprise that a vibrant lexicon has emerged . . .

- Which of the following phrases is **closest** in meaning to *vibrant lexicon*?
- A. vivid detail
 - B. official motto
 - C. lively vocabulary
 - D. odd pronunciation

Question 36 is an open-response question.

- Read the question carefully.
- Explain your answer.
- Add supporting details.
- Double-check your work.

Write your answer to question 36 in the space provided in your Student Answer Booklet.

- 36 Based on the article, explain the reasons why sanitation workers have developed their own slang. Support your answer with relevant and specific information from the article.

In this essay, the author recalls how the arrival of electricity to his grandmother's small farm community allowed her family to enjoy her prized corn all year long. Discover how his grandmother's dedication to her work affects the author to this day. Read the essay and answer the questions that follow.

SWEET CORN

by Tony Earley

Students read a selection titled "Sweet Corn" and then answered questions 37 through 40 that follow on page 195 of this document.

Due to copyright restrictions, the selections cannot be released to the public over the Internet. For more information, see the copyright citation below.

Reprinted by the permission of Regal Literary as agent for Tony Earley.
Copyright © 2007 by Tony Earley.

Due to copyright restrictions, the selection that appeared on this page cannot be released to the public over the Internet. For more information, see the citation on the previous page.

- 37 How does the author develop paragraph 1 of the essay?
- A. He compares the past to the present.
 - B. He describes his reasons for writing the essay.
 - C. He begins with a problem and shows the solution.
 - D. He begins with background and narrows to a focus.

- 38 Read the sentence from paragraph 3 in the box below.

You can mimic the motions that she used to conjure up her masterpiece, but not the results.

- Based on the sentence, in what way was Granny’s corn **most** like a work of art?
- A. It was beautiful to look at.
 - B. It was impossible to duplicate.
 - C. It was made according to a rigid plan.
 - D. It was intended to make people happy.

- 39 Based on paragraph 5, what does the author suggest about his grandmother’s seventy years of farm life?
- A. It was a relaxing life.
 - B. It was a fulfilling life.
 - C. It was an isolated life.
 - D. It was a thankless life.

- 40 Reread the last sentence of the essay. What point does the author make about Granny in the sentence?
- A. Granny’s hard work was rarely appreciated by her family.
 - B. Granny always resented the demands her family put on her.
 - C. Granny made the corn primarily because she loved to work.
 - D. Granny’s love for her family was shown through her efforts.

Grade 8 English Language Arts
Reading Comprehension
Spring 2007 Released Items:
Reporting Categories, Standards, and Correct Answers

Item No.	Page No.	Reporting Category	Standard	Correct Answer (MC)*
1	174	<i>Reading and Literature</i>	8	C
2	174	<i>Reading and Literature</i>	13	D
3	174	<i>Reading and Literature</i>	13	D
4	174	<i>Language</i>	4	D
5	175	<i>Reading and Literature</i>	13	C
6	175	<i>Reading and Literature</i>	8	C
7	175	<i>Reading and Literature</i>	15	D
8	175	<i>Language</i>	4	B
9	176	<i>Reading and Literature</i>	13	
10	178	<i>Reading and Literature</i>	14	D
11	178	<i>Reading and Literature</i>	14	C
12	178	<i>Reading and Literature</i>	14	A
13	178	<i>Reading and Literature</i>	14	D
14	178	<i>Language</i>	4	A
15	182	<i>Reading and Literature</i>	16	A
16	182	<i>Reading and Literature</i>	16	D
17	182	<i>Reading and Literature</i>	16	D
18	182	<i>Reading and Literature</i>	16	A
19	182	<i>Reading and Literature</i>	16	B
20	183	<i>Reading and Literature</i>	16	
21	186	<i>Reading and Literature</i>	12	A
22	186	<i>Reading and Literature</i>	12	A
23	186	<i>Reading and Literature</i>	12	B
24	186	<i>Reading and Literature</i>	15	B
25	187	<i>Reading and Literature</i>	12	D
26	187	<i>Reading and Literature</i>	12	A
27	187	<i>Language</i>	4	B
28	187	<i>Reading and Literature</i>	12	
29	190	<i>Reading and Literature</i>	13	C
30	190	<i>Reading and Literature</i>	13	D
31	191	<i>Reading and Literature</i>	8	B
32	191	<i>Reading and Literature</i>	15	B
33	191	<i>Reading and Literature</i>	13	C
34	191	<i>Reading and Literature</i>	13	C
35	191	<i>Language</i>	4	C
36	192	<i>Reading and Literature</i>	13	
37	195	<i>Reading and Literature</i>	13	D
38	195	<i>Reading and Literature</i>	15	B
39	195	<i>Reading and Literature</i>	8	B
40	195	<i>Reading and Literature</i>	8	D

* Answers are provided here for multiple-choice items only. Sample responses and scoring guidelines for open-response items, which are indicated by shaded cells, will be posted to the Department's Web site later this year.

VIII. English Language Arts, Grade 10

A. Composition

B. Reading Comprehension

Grade 10 English Language Arts Test

Test Structure

The grade 10 MCAS English Language Arts test was presented in the following two parts:

- the ELA Composition test, which used a writing prompt to assess learning standards from the Massachusetts *English Language Arts Curriculum Framework's* **Composition** strand
- the ELA Reading Comprehension test, which used multiple-choice and open-response questions (items) to assess learning standards from the *Curriculum Framework's* **Language** and **Reading and Literature** strands

A. Composition

The spring 2007 grade 10 MCAS English Language Arts Composition test and Composition Make-Up test were based on learning standards in the **Composition** strand of the Massachusetts *English Language Arts Curriculum Framework* (2001). The learning standards appear on pages 72–83 of the *Framework*, which is available on the Department Web site at www.doe.mass.edu/frameworks/current.html.

In *Test Item Analysis Reports* and on the Subject Area Subscore pages of the MCAS *School Reports* and *District Reports*, ELA Composition test results are reported under the reporting categories **Composition: Topic Development** and **Composition: Standard English Conventions**.

Test Sessions and Content Overview

The MCAS ELA Composition test included two separate test sessions, administered on the same day with a short break between sessions. During the first session, each student wrote an initial draft of a composition in response to the appropriate writing prompt on the next page. During the second session, each student revised his or her draft and submitted a final composition, which was scored in the areas of Topic Development and Standard English Conventions. The MCAS Writing Score Guide (Composition Grade 10) is available at www.doe.mass.edu/mcas/student/scoring10.doc.

Reference Materials and Tools

At least one English-language dictionary per classroom was provided for student use during ELA Composition test sessions. The use of bilingual dictionaries was allowed for current and former limited English proficient students only. No other reference materials or tools were allowed during either ELA Composition test session.

Cross-Reference Information

Framework general standards 19–22 are assessed by the ELA Composition.

English Language Arts Composition, Grade 10

Grade 10 Writing Prompt

WRITING PROMPT

Works of literature often feature characters who overcome hardship and misfortune.

From a work of literature you have read in or out of school, select a character who overcomes hardship and misfortune. In a well-developed composition, explain how the character overcomes adversity and why this success is important to the work of literature.

Grade 10 Make-Up Writing Prompt

WRITING PROMPT

Often in works of literature, characters have a mixture of positive and negative traits.

From a work of literature you have read in or out of school, select a character who blends positive and negative traits. In a well-developed composition, identify the character, describe how the character demonstrates both positive and negative traits, and explain how the character's traits are important to the work of literature.

B. Reading Comprehension

The spring 2007 grade 10 MCAS English Language Arts Reading Comprehension test was based on learning standards in the two content strands of the Massachusetts *English Language Arts Curriculum Framework* (2001) listed below. Page numbers for the learning standards appear in parentheses.

- Language (*Framework*, pages 19–26)
- Reading and Literature (*Framework*, pages 35–64)

The *English Language Arts Curriculum Framework* is available on the Department Web site at www.doe.mass.edu/frameworks/current.html.

In *Test Item Analysis Reports* and on the Subject Area Subscore pages of the MCAS *School Reports* and *District Reports*, ELA Reading Comprehension test results are reported under two MCAS reporting categories: **Language** and **Reading and Literature**, which are identical to the two Framework content strands listed above.

Test Sessions and Content Overview

The MCAS grade 10 ELA Reading Comprehension test included three separate test sessions. Sessions 1 and 2 were both administered on the same day, and Session 3 was administered on the following day. Each session included selected readings, followed by multiple-choice and open-response questions. Common reading passages and test items are shown on the following pages as they appeared in test booklets. Due to copyright restrictions, certain reading passages cannot be released to the public on the Web site. For further information, contact Student Assessment Services at 781-338-3625.

Reference Materials and Tools

The use of bilingual word-to-word dictionaries was allowed for current and former limited English proficient students only, during all three ELA Reading Comprehension test sessions. No other reference materials were allowed during any ELA Reading Comprehension test session.

Cross-Reference Information

The table at the conclusion of this chapter indicates each item's reporting category and the *Framework* general standard it assesses. The correct answers for multiple-choice questions are also displayed in the table.

English Language Arts

READING COMPREHENSION: SESSION 1

DIRECTIONS

This session contains three reading selections with seventeen multiple-choice questions and two open-response questions. Mark your answers to these questions in the spaces provided in your Student Answer Booklet.

John Gill, a rock climber from Pueblo, Colorado, is considered a legend in his sport. Read “Gill,” an excerpt from a true story in the book Eiger Dreams, and learn what makes him so well respected by climbers everywhere. Answer the questions that follow.

GILL

by Jon Krakauer

Students read a selection titled “Gill” and then answered questions 1 through 9 that follow on pages 203–205 of this document.

Due to copyright restrictions, the selections cannot be released to the public over the Internet. For more information, see the copyright citation below.

From EIGER DREAMS by Jon Krakauer. Copyright © 1990 by Jon Krakauer. Reprinted by permission of The Lyons Press, an imprint of The Globe Pequot Press.

Due to copyright restrictions, the selection that appeared on this page cannot be released to the public over the Internet. For more information, see the citation on the previous page.

Due to copyright restrictions, the selection that appeared on this page cannot be released to the public over the Internet. For more information, see the citation on page 201.

- 1 According to the excerpt, which of the following is true of bouldering?
- A. It is a mental activity as well as a physical one.
 - B. It is more dangerous than regular mountain climbing.
 - C. It appeals mainly to research mathematicians.
 - D. It emphasizes reaching one's goal instead of the process of climbing.

- 2 According to the excerpt, which of the following **best** describes how Gill approaches climbing a boulder?
- A. He solves his climbing problems one handhold at a time.
 - B. He uses his knowledge of mathematics to determine the rock's measurements.
 - C. He draws on his skills as a former gymnast.
 - D. He looks for the pattern on the rock face before climbing.

- 3 What does Gill **most likely** mean when he says in paragraph 6 that climbing has “metaphysical, mystical, and philosophical overtones”?
- A. Climbing demands many hours of training in geology.
 - B. Climbing requires careful, deliberate body building.
 - C. Climbing demands long periods of religious preparation.
 - D. Climbing is much more than just an athletic activity.

- 4 Read the sentence from paragraph 7 in the box below.

He speaks the same way he moves—slowly, deliberately, with meticulously chosen words uttered in grammatically perfect sentences.

What can the reader learn about Gill from this description?

- A. Gill doubts his ability to communicate well with others.
- B. Gill conserves energy by moving and speaking slowly.
- C. Gill is purposeful and precise in his actions.
- D. Gill is purposely reserved when meeting new people.

- 5 According to the excerpt, how are mountain climbers different from boulderers?
- A. Mountain climbers usually climb in groups, while boulderers prefer to climb alone.
 - B. Mountain climbers perform death-defying deeds, while boulderers try not to take many risks.
 - C. Mountain climbers are part of an elite group, while boulderers are just common people.
 - D. Mountain climbers are concerned with reaching the top, while boulderers focus on the act of climbing.

- 6 What is this excerpt **mainly** about?
- A. how one of the world’s greatest climbers approaches his sport
 - B. how bouldering, once reserved for mathematicians, is becoming a popular sport
 - C. how climbers can find interesting patterns in almost any rock if they concentrate
 - D. how a famous climber got started on a lifetime of bouldering

- 7 The word *nascent* is derived from the Latin verb *nasci*, which means “to be born.” Which of the following **most nearly** means the same as the word *nascent* in paragraph 1?
- A. hidden
 - B. emerging
 - C. discovered
 - D. grown
- 8 Which of the following is the **best** meaning of the word *stymied* as it is used in paragraph 2?
- A. confused
 - B. steady
 - C. stuck
 - D. energized

Question 9 is an open-response question.

- **Read the question carefully.**
- **Explain your answer.**
- **Add supporting details.**
- **Double-check your work.**

Write your answer to question 9 in the space provided in your Student Answer Booklet.

- 9 Based on the excerpt, explain how Gill finds climbing boulders and solving mathematics equations to be similar. Use relevant and specific information from the excerpt to support your answer.

Do you have memories of an older relative or friend? In this excerpt from *Silent Dancing: A Partial Remembrance of a Puerto Rican Childhood*, Judith Ortiz Cofer recalls childhood memories of her grandmother's house. Read to find out what she remembers about her grandmother. Then answer the questions that follow.

More Room

by JUDITH ORTIZ COFER

1 **m**y grandmother's house is like a chambered nautilus; it has many rooms, yet it is not a mansion. Its proportions are small and its design simple. It is a house that has grown organically, according to the needs of its inhabitants. To all of us in the family it is known as *la casa de Mamá*. It is the place of our origin; the stage for our memories and dreams of Island life.

2 I remember how in my childhood it sat on stilts; this was before it had a downstairs—it rested on its perch like a great blue bird—not a flying sort of bird, more like a nesting hen, but with spread wings. Grandfather had built it soon after their marriage. He was a painter and housebuilder by trade—a poet and meditative man by nature. As each of their eight children were born, new rooms were added. After a few years, the paint didn't exactly match, nor the materials, so that there was a chronology to it, like the rings of a tree, and Mamá could tell you the history of each room in her *casa*, and thus the geneology of the family along with it.

3 Her own room is the heart of the house. Though I have seen it recently—and both woman and room have diminished in size, changed by the new perspective of my eyes, now capable of looking over countertops and tall beds—it is not this picture I carry in my memory of Mamá's *casa*. Instead, I see her room as a queen's chamber where a small woman loomed large, a throne room with a massive four-poster bed in its center, which stood taller than a child's head. It was on this bed, where her own children had been born, that the smallest grandchildren were allowed to take naps in the afternoons; here too was where Mamá secluded herself to dispense private advice to her daughters, sitting on the edge of the bed, looking down at whoever sat on the rocker where generations of babies had been sung to sleep. To me she looked like a wise empress right out of the fairy tales I was addicted to reading.

4 Though the room was dominated by the mahogany four-poster, it also contained all of Mamá's symbols of power. On her dresser there were not cosmetics but jars filled with herbs: *yerba* we were all subjected to during childhood crises. She had a steaming cup for anyone who could not, or would not, get up to face life on any given day. If the acrid aftertaste of her cures for malingering did not get you out of bed, then it was time to call *el doctor*.

5 And there was the monstrous chifforobe she kept locked with a little golden key she did not hide. This was a test of her dominion over us; though my cousins and I wanted a look inside that massive wardrobe more than anything, we never reached for that little key lying on top of her Bible on the dresser. This was also where she placed her earrings and rosary when she took them off at night. God's word was her security system. This chifforobe was the place where I imagined she kept jewels, satin

slippers, and elegant silk, sequined gowns of heartbreaking fineness. I lusted after those imaginary costumes. I had heard that Mamá had been a great beauty in her youth, and the belle of many balls. My cousins had ideas as to what she kept in that wooden vault: its secret could be money (Mamá did not hand cash to strangers, banks were out of the question, so there were stories that her mattress was stuffed with dollar bills, and that she buried coins in jars in her garden under rose-bushes, or kept them in her inviolate chifforobe); there might be that legendary gun salvaged from the Spanish-American conflict over the Island. We went wild over suspected treasures that we made up simply because children have to fill locked trunks with something wonderful.

...

“More Room” is reprinted with permission from the publisher of *Silent Dancing: A Partial Remembrance of a Puerto Rican Childhood* by Judith Ortiz Cofer (Arte Público Press — University of Houston, 1990).

-
- 10 Which of the following **best** expresses a theme in the excerpt?
- A. Living in the past prevents people from growing.
 - B. Good behavior brings happiness and prosperity.
 - C. Memory helps people stay connected to things they cherish.
 - D. Adults often forget their childhood memories.
- 11 In paragraph 2, the speaker states that the house had a “chronology to it.” What is the **most likely** meaning of the phrase?
- A. Its architecture reveals the cultural and social history of its time.
 - B. Its changing structure reflects the history of its occupants.
 - C. It contains objects from many different cultures throughout history.
 - D. Its simple design and small size reflect the family’s history.

- 12 In paragraph 3, what does the author mean by the statement “both woman and room have diminished in size”?
- A. Mamá and her room have faded from the author’s memory.
 - B. Mamá and her room have deteriorated with age.
 - C. Mamá and her room are physically smaller than they used to be.
 - D. Mamá and her room appear smaller to the author as an adult.

- 13 In the excerpt, what is the effect of the author’s use of images such as “queen’s chamber,” “throne room,” and “sequined gowns of heartbreaking fineness”?
- A. It indicates Mamá was old-fashioned.
 - B. It suggests the family’s elevated status.
 - C. It shows that Mamá was powerful.
 - D. It reveals the family’s ties to royalty.

How much of what we learn adequately explains the world around us? Read the poem “When I Heard the Learn’d Astronomer” to learn what the poet has to say about this question. Answer the questions that follow.

When I Heard the Learn’d Astronomer

- 1 When I heard the learn’d astronomer,
- 2 When the proofs, the figures, were ranged in columns
before me,
- 3 When I was shown the charts and diagrams, to add,
divide, and measure them,
- 4 When I, sitting, heard the astronomer where he lectured
with much applause in the lecture room,
- 5 How soon unaccountable I became tired and sick,
- 6 Till rising and gliding out I wander’d off by myself,
- 7 In the mystical* moist night air, and from time to time,
- 8 Look’d up in perfect silence at the stars.

—Walt Whitman

* *mystical* — mysterious

In the public domain.

- 14 Which of the following statements represents the **main** theme of the poem?
- A. Science cannot fully express the wonder of the world.
 - B. Nature is one's best source of recreation.
 - C. Technology causes more problems than it solves.
 - D. Learning causes one to become ill and fatigued.
- 15 In line 5, what is conveyed by the phrase "tired and sick"?
- A. the speaker's sorrow and loss experienced in his life
 - B. a sense of approaching danger
 - C. a sense of the speaker's poor health
 - D. the speaker's boredom and disappointment with the lecture
- 16 What is the **main purpose** of the phrase "perfect silence" in the last line of the poem?
- A. to explain why he has to leave the lecture room
 - B. to convey a sense of loneliness and sorrow
 - C. to contrast with the sounds in the lecture room
 - D. to highlight the pleasure of science and learning
- 17 What do the last three lines of the poem suggest?
- A. the importance of personal experience with nature
 - B. the dangers of losing track of time
 - C. the importance of learning about astronomy
 - D. the dangers of wandering off alone
- 18 Which of the following is the **best** synonym for the word *learn'd* as it is used in line 1?
- A. aware
 - B. remembered
 - C. knowledgeable
 - D. invented

Question 19 is an open-response question.

- Read the question carefully.
- Explain your answer.
- Add supporting details.
- Double-check your work.

Write your answer to question 19 in the space provided in your Student Answer Booklet.

- 19 In the poem, a shift occurs at the end of line 4.
- a. Explain what happens before and after the shift.
 - b. Explain what causes the shift.

Use relevant and specific information from the poem to support your answer.

English Language Arts

READING COMPREHENSION: SESSION 2

DIRECTIONS

This session contains one reading selection with seven multiple-choice questions and one open-response question. Mark your answers to these questions in the spaces provided in your Student Answer Booklet.

The novel Girl With a Pearl Earring is set in Holland in the 1600s. In this excerpt, sixteen-year-old Griet is confronted with a surprising development in her life. Learn what causes the turn of events and how she deals with it. Read the excerpt and answer the questions that follow.

GIRL WITH A PEARL EARRING

by *Tracy Chevalier*

Students read a selection titled *Girl With a Pearl Earring* and then answered questions 20 through 27 that follow on pages 215–217 of this document.

Due to copyright restrictions, the selection cannot be released to the public over the Internet. For more information, see the copyright citation below.

From GIRL WITH A PEARL EARRING by Tracy Chevalier, copyright © 1999 by Tracy Chevalier. Used by permission of Plume, an imprint of Penguin Group (USA) Inc.

Due to copyright restrictions, the selection that appeared on this page cannot be released to the public over the Internet. For more information, see the citation on the previous page.

Due to copyright restrictions, the selection that appeared on this page cannot be released to the public over the Internet. For more information, see the citation on page 212.

- 20 In the excerpt, the action is seen through Griet's eyes. What does this help the reader do?
- A. to understand her mother's actions
 - B. to feel sympathy for her
 - C. to foreshadow the ending
 - D. to appreciate the talent of Vermeer
- 21 In the excerpt, Griet's narration contains a great deal of visual imagery. What does this reveal about her?
- A. Griet often describes scenes for her father.
 - B. Griet enjoys looking at the fine possessions of the rich people.
 - C. Griet notices details the way an artist would.
 - D. Griet is learning to paint scenes on tiles.
- 22 Reread paragraph 15. What does the fact that Catharina's expression "flickered like a candle" reveal about her?
- A. She is uneasy.
 - B. She is demanding.
 - C. She is jealous.
 - D. She is exhausted.
- 23 In paragraphs 16 through 24, what can the reader tell from the fact that the man asks questions, while Griet does not?
- A. He does not know how to make soup, and she does.
 - B. He has a position of authority, and she does not.
 - C. He does not want to hire her, but she needs the job.
 - D. He is friendly and talkative, but she is shy.

- 24 Read the sentence from paragraph 24 in the box below.

He arched his eyebrows, as if he had not expected such a response.

What does the sentence suggest about Vermeer?

- A. He is surprised Griet can cook.
- B. He recognizes Griet's artistic instincts.
- C. He thinks Griet is being rude.
- D. He is interested in Griet's soup recipe.

- 25 In the excerpt, which of Vermeer's actions suggests that he thinks like an artist?

- A. He calls the vegetables by their colors instead of their names.
- B. He calms his wife when she knocks the knife off the table.
- C. He asks Griet to clean his studio.
- D. He allows his wife to make the decision to hire Griet.

- 26 According to the excerpt, what consolation does the father have about Griet's job?

- A. He thinks she will learn to paint.
- B. He thinks her employer will be good to her.
- C. He believes she will make a lot of money.
- D. He hopes she will learn to be a good maid.

Question 27 is an open-response question.

- Read the question carefully.
- Explain your answer.
- Add supporting details.
- Double-check your work.

Write your answer to question 27 in the space provided in your Student Answer Booklet.

- 27 Based on the excerpt, describe Griet's character. Use relevant and specific information from the excerpt to support your answer.

English Language Arts

READING COMPREHENSION: SESSION 3

DIRECTIONS

This session contains two reading selections with twelve multiple-choice questions and one open-response question. Mark your answers to these questions in the spaces provided in your Student Answer Booklet.

America's Test Kitchen shares the results of its approach to making foolproof traditional recipes. The following article includes tips and information for preparing New England clam chowder. Read the article and answer the questions that follow.

NEW ENGLAND CLAM CHOWDER

WHAT WE WANTED: A delicious, traditional chowder that was economical, would not curdle,¹ and could be prepared quickly.

- W**e love homemade clam chowder almost as much as we love good chicken soup. After all, our test kitchen is located just outside of Boston, in the heart of chowder country. But we must confess that many cooks (including some that work in our test kitchen) don't make their own chowder. While they might never buy chicken soup, they seem willing to make this compromise. We wondered why.
- Time certainly isn't the reason. You can prepare clam chowder much more quickly than you can a pot of good chicken soup. The reason why many cooks don't bother making their own clam chowder is the clams. First of all, clams can be expensive. Second, clams are not terribly forgiving—you must cook them soon after their purchase (chickens can be frozen), and then the chowder itself must be quickly consumed (again, chicken soup can be frozen or at least refrigerated for another day). Last, chowders are more fragile (and thus more fickle) than most soups. Unless

the chowder is stabilized in some way, it's likely to curdle, especially when brought to a boil.

- Before testing chowder recipes, we explored our clam options. Chowders are typically made with hard-shell clams (rather than soft-shell clams, such as steamers), so we purchased (from smallest to largest) cockles, littlenecks, cherrystones, and chowder clams, often called quahogs (pronounced ko-hogs).
- Although they made delicious chowders, we eliminated littlenecks and cockles, both of which were just too expensive to toss into a chowder pot. Chowders made with the cheapest clams, however, weren't satisfactory. The quahogs we purchased for testing were large (4 to 5 inches in diameter), tough, and strong flavored. Their oversized bellies (and the contents therein) gave the chowder an overbearing mineral taste, detracting from its smooth, rich flavor.
- Though only a little more expensive than quahogs, cherrystones offered good value and flavor. The chowder made from these slightly smaller clams was distinctly clam flavored, without an inky aftertaste. Because there are no industry sizing standards for

¹ *curdle* — to thicken into clots

each clam variety, you may find some small quahogs labeled cherrystones or large cherrystones labeled quahogs. Regardless of designation, clams much over 4 inches in diameter will deliver a distinctly metallic, inky-flavored chowder.

6 Some recipes suggest shucking² raw clams and then adding the raw clam bellies to the pot. Other recipes steam the clams open. We tested both methods and found that steaming the clams open is far easier than shucking them. After seven to nine minutes over simmering water, clams open as naturally as budding flowers. Ours did not toughen up as long as we pulled them from the pot as soon as they opened and didn't let them cook too long in the finished chowder.

7 Although many chowder recipes instruct the cook to soak the clams in salt water spiked with cornmeal or baking powder to remove grit, we found the extra step of purging or filtering hard-shell clams to be unnecessary. All of the hard-shells we tested were relatively clean, and what little sediment there was sank to the bottom of the steaming liquid. Getting rid of the grit was as simple as leaving the last few tablespoons of broth in the pan when

TECHNIQUE: Scrubbing Clams



Many recipes instruct the cook to scrub clams. Don't skip this step; many clams have bits of sand embedded in their shells that can ruin a pot of chowder. We like to scrub clams under cold, running water using a soft brush, sometimes sold in kitchen shops as a vegetable brush.

pouring it from the pot. If you find that your clam broth is gritty, strain it through a coffee filter.

8 At this point, we turned our attention to texture. We wanted a chowder that was thick but still a soup rather than a stew. Older recipes call for thickening clam chowder with crumbled biscuits; bread crumbs and crackers are modern stand-ins.

9 Chowders thickened with bread crumbs failed to impress. We wanted a smooth,

TECHNIQUE: Steaming Clams for Chowder



1. Steam clams until they just open, as shown on the left, rather than completely open, as shown at the right.

2. Using a paring knife, open the clams carefully, holding each one over a bowl to catch any juices that are released.

3. When open, discard the top shell and use the knife to sever the muscle that connects the clam to the bottom shell.

² *shucking* — removing the shell from

creamy soup base for the potatoes, onions, and clams, but no matter how long the chowder simmered, neither the bread crumbs nor crackers ever completely dissolved into the cooking liquid. Heavy cream alone, by contrast, did not give the chowder enough body. We discovered fairly quickly that flour was necessary not only as a thickener but also as a stabilizer; unthickened chowders separate and curdle.

10 Most recipes for chowder call for potatoes, some of them calling specifically for starchy baking potatoes, which tend to break down when boiled and so can double as a thickener. In our tests, these potatoes did not break down sufficiently but instead simply became soft and mushy. We found waxy red boiling potatoes to be best for creamy-style chowders. They have a firm but tender texture, and their red skins look appealing.

11 We now had two final questions to answer about New England clam chowder. First, should it include salt pork or bacon, and, if the latter, did the bacon need to be blanched?³ Second, should the chowder be enriched with milk or cream?

12 Salt pork and bacon both come from the pig's belly. Salt pork is cured in salt, while bacon is smoked, and salt pork is generally fattier than bacon. Salt pork is the more traditional choice in chowder recipes,

although bacon has become popular in recent decades, no doubt because of its availability. Jasper White writes in *Fifty Chowders* (Scribners, 2000), his definitive book on the subject, that chowders made years ago with salt pork often had a smoky flavor because they were also cooked over an open hearth. For modern cooks, bacon adds both the pork and the smoky flavor.

13 We made clam chowder with both salt pork and bacon, and tasters liked both versions. Frankly, we ended up using such small amounts of pork in our final recipe that either salt pork or bacon is fine. Bacon is more readily available and, once bought, easier to use up. Blanching the bacon makes it taste more like salt pork, but we rather liked the subtle smokiness of the chowder made with unblanched bacon.

14 As for the cream versus milk issue, we found that so much milk was required to make the chowder look and taste creamy that it began to lose its clam flavor and became more like mild bisque⁴ or the clam equivalent of oyster stew. Making the chowder with almost all clam broth (5 cups of the cooking liquid from the steaming clams), then finishing the stew with a cup of cream, gave us what we were looking for: a rich, creamy chowder that tasted distinctly of clams.

FOOD FACT: Chowder

Historically, chowder was improvised according to available seasonal ingredients. In France, fishermen would toss a portion of the day's catch into a *chaudiere*, a large, three-legged iron cooking pot. Hence the name chowder.

Today, the term chowder is used to refer to a soup thickened with potatoes and often cream. Bacon plays an important role in almost all chowder recipes. Along the East Coast, there are two styles of clam chowder – those made with dairy, popular in Massachusetts and Maine (we generally call these soups New England clam chowders) and those made with tomatoes. This second style was first popularized in Rhode Island but eventually became known as Manhattan clam chowder.

³ *blanched* — boiled briefly

⁴ *bisque* — thick cream soup

- 28 What is the author's **most likely** purpose for beginning the article with a description of a puzzling fact?
- A. to prove a point that is often disputed
 - B. to establish a pattern for the rest of the article
 - C. to explain the motivation for the research that follows
 - D. to present different perspectives about cooking to readers
- 29 According to paragraph 2, what is one reason most cooks do not make their own clam chowder?
- A. Buying clams can be costly.
 - B. Finding clams can be difficult.
 - C. Preparing clams for the soup is time consuming.
 - D. Removing clams from their shells is challenging.
- 30 According to paragraphs 4 and 5, why did the testers choose cherrystone clams for their clam chowder recipe?
- A. They are less expensive than the larger clams.
 - B. They are easier to clean than the soft-shelled clams.
 - C. They are better tasting than the less expensive clams.
 - D. They are more plentiful than the more expensive clams.
- 31 According to paragraph 9, what is the **best** thickening agent for clam chowder?
- A. flour
 - B. potatoes
 - C. bread crumbs
 - D. crumbled biscuits
- 32 What is the **main** purpose of the information in the box titled "FOOD FACT: Chowder"?
- A. to describe the origins of chowder
 - B. to describe thickeners used in chowder
 - C. to compare the kinds of potatoes used in chowder
 - D. to contrast cream and tomatoes as bases for chowder
- 33 Which of the following statements **best** characterizes the article's main conclusion?
- A. Good clam chowder can be prepared at home.
 - B. The best clam chowder is made in New England.
 - C. Amateur cooks should experiment with chowder techniques.
 - D. Test kitchen cooks are undecided about the best chowder recipe.

- 34 Which of the following is the **best** synonym for the word *overbearing* as it is used in paragraph 4?
- A. delicate
 - B. dominant
 - C. satisfying
 - D. interesting

- 35 To whom does the pronoun *we* refer throughout the article?
- A. food critics
 - B. clam fishermen
 - C. test kitchen staff
 - D. restaurant owners

Question 36 is an open-response question.

- **Read the question carefully.**
- **Explain your answer.**
- **Add supporting details.**
- **Double-check your work.**

Write your answer to open-response question 36 in the space provided in your Student Answer Booklet.

- 36 Using the information from the article, describe how you could use the authors' discoveries to make clam chowder at home. Support your answer with relevant and specific details from the article.

In this chapter from *Mythology*, author Edith Hamilton retells the story of King Ceyx and his faithful wife, Queen Alcyone. Read the myth and answer the questions that follow.

CEYX AND ALCYONE

by Edith Hamilton

- 1 Ceyx, a king in Thessaly,¹ was the son of Lucifer, the light-bearer, the star that brings in the day,² and all his father's bright gladness was in his face. His wife Alcyone was also of high descent; she was the daughter of Aeolus, King of the Winds. The two loved each other devotedly and were never willingly apart. Nevertheless, a time came when he decided he must leave her and make a long journey across the sea. Various matters had happened to disturb him and he wished to consult the oracle,³ men's refuge in trouble. When Alcyone learned what he was planning she was overwhelmed with grief and terror. She told him with streaming tears and in a voice broken with sobs, that she knew as few others could the power of the winds upon the sea. In her father's palace she had watched them from her childhood, their stormy meetings, the black clouds they summoned and the wild red lightning. "And many a time upon the beach," she said, "I have seen the broken planks of ships tossed up. Oh, do not go. But if I cannot persuade you, at least take me with you. I can endure whatever comes to us together."
- 2 Ceyx was deeply moved, for she loved him no better than he loved her, but his purpose held fast. He felt that he must get counsel from the oracle and he would not hear of her sharing the perils of the voyage. She had to yield and let him go alone. Her heart was so heavy when she bade him farewell it was as if she foresaw what was to come. She waited on the shore watching the ship until it sailed out of sight.
- 3 That very night a fierce storm broke over the sea. The winds all met in a mad hurricane, and the waves rose up mountain-high. Rain fell in such sheets that the whole heaven seemed falling into the sea and the sea seemed leaping up into the sky. The men on the quivering, battered boat were mad with terror, all except one who thought only of Alcyone and rejoiced that she was in safety. Her name was on his lips when the ship sank and the waters closed over him.
- 4 Alcyone was counting off the days. She kept herself busy, weaving a robe for him against his return and another for herself to be lovely in when he first saw her. And many times each day she prayed to the gods for him, to Juno most of all. The goddess was touched by those prayers for one who had long been dead. She summoned her messenger Iris and ordered her to go to the house of Somnus, God of Sleep, and bid him send a dream to Alcyone to tell her the truth about Ceyx.

¹Thessaly — region of northern Greece

²the star that brings in the day — a reference to the planet Venus as seen at dawn

³oracle — a person, such as a priest or priestess of ancient Greece, through whom a deity is believed to speak

- 5 The abode of Sleep is near the black country of the Cimmerians,⁴ in a deep valley where the sun never shines and dusky twilight wraps all things in shadows. No cock crows there; no watchdog breaks the silence; no branches rustle in the breeze; no clamor of tongues disturbs the peace. The only sound comes from the gently flowing stream of Lethe, the river of forgetfulness, where the waters murmuring entice to sleep. Before the door poppies bloom, and other drowsy herbs. Within, the God of Slumber lies upon a couch downy-soft and black of hue. There came Iris in her cloak of many colors, trailing across the sky in a rainbow curve, and the dark house was lit up with the shining of her garments. Even so, it was hard for her to make the god open his heavy eyes and understand what he was required to do. As soon as she was sure he was really awake and her errand done, Iris sped away, fearful that she too might sink forever into slumber.
- 6 The old God of Sleep aroused his son, Morpheus, skilled in assuming the form of any and every human being, and he gave him Juno's orders. On noiseless wings Morpheus flew through the darkness and stood by Alcyone's bed. He had taken on the face and form of Ceyx drowned. Naked and dripping wet he bent over her couch. "Poor wife," he said, "look, your husband is here. Do you know me or is my face changed in death? I am dead, Alcyone. Your name was on my lips when the waters overwhelmed me. There is no hope for me any more. But give me your tears. Let me not go down to the shadowy land unwept." In her sleep Alcyone moaned and stretched her arms out to clasp him. She cried aloud, "Wait for me. I will go with you," and her cry awakened her. She woke to the conviction that her husband was dead, that what she had seen was no dream, but himself. "I saw him, on that very spot," she told herself. "So piteous he looked. He is dead and soon I shall die. Could I stay here when his dear body is tossed about in the waves? I will not leave you, my husband; I will not try to live."
- 7 With the first daylight she went to the shore, to the headland where she had stood to watch him sail away. As she gazed seaward, far off on the water she saw something floating. The tide was setting in and the thing came nearer and nearer until she knew it was a dead body. She watched it with pity and horror in her heart as it drifted slowly toward her. And now it was close to the headland, almost beside her. It was he, Ceyx, her husband. She ran and leaped into the water, crying, "Husband, dearest!"—and then oh, wonder, instead of sinking into the waves she was flying over them. She had wings; her body was covered with feathers. She had been changed into a bird. The gods were kind. They did the same to Ceyx. As she flew to the body it was gone, and he, changed into a bird like herself, joined her. But their love was unchanged. They are always seen together, flying or riding the waves.
- 8 Every year there are seven days on end when the sea lies still and calm; no breath of wind stirs the waters. These are the days when Alcyone broods over her nest floating on the sea. After the young birds are hatched the charm is broken; but each winter these days of perfect peace come, and they are called after her, Alcyon, or, more commonly, Halcyon days.

⁴ *Cimmerians* — an ancient people living north of the Black Sea in what is now southern Russia

"Ceyx and Alcyone" from *Mythology* by Edith Hamilton. Copyright © 1942 by Edith Hamilton; copyright © renewed 1969 by Dorian Fielding Reid and Doris Fielding Reid. By permission of Little, Brown and Co.

- 37 According to paragraph 2, why does Ceyx refuse to allow Alcyone to accompany him?
- A. Ceyx fears that Alcyone is likely to bring him misfortune.
 - B. Ceyx wants Alcyone to manage the household in his absence.
 - C. Ceyx believes Alcyone is forbidden to seek advice from the oracle.
 - D. Ceyx wishes to prevent Alcyone from being exposed to any danger.
- 38 According to paragraphs 6–7, what motivates Alcyone to return to the headland?
- A. She plans to take a journey across the sea.
 - B. She hopes to find a cure for her sleeplessness.
 - C. She wishes to ask the oracle about her dream.
 - D. She wants to be close to her drowned husband.
- 39 Which of the following ideas is **most clearly** supported by the myth?
- A. defiance of the will of the gods
 - B. admiration for devotion between mortals
 - C. appreciation of the beauty found in nature
 - D. hopelessness of achieving human perfection
- 40 According to the information in paragraph 8, which of the following is the **best** synonym for the word *halcyon*?
- A. joyful
 - B. reborn
 - C. serene
 - D. unending

**Grade 10 English Language Arts
Reading Comprehension
Spring 2007 Released Items:
Reporting Categories, Standards, and Correct Answers**

Item No.	Page No.	Reporting Category	Standard	Correct Answer (MC)*
1	203	<i>Reading and Literature</i>	8	A
2	203	<i>Reading and Literature</i>	8	D
3	204	<i>Reading and Literature</i>	13	D
4	204	<i>Reading and Literature</i>	8	C
5	204	<i>Reading and Literature</i>	8	D
6	204	<i>Reading and Literature</i>	8	A
7	205	<i>Language</i>	4	B
8	205	<i>Language</i>	4	C
9	205	<i>Reading and Literature</i>	13	
10	207	<i>Reading and Literature</i>	11	C
11	207	<i>Reading and Literature</i>	12	B
12	208	<i>Reading and Literature</i>	12	D
13	208	<i>Reading and Literature</i>	15	C
14	210	<i>Reading and Literature</i>	11	A
15	210	<i>Reading and Literature</i>	14	D
16	210	<i>Reading and Literature</i>	14	C
17	210	<i>Reading and Literature</i>	14	A
18	210	<i>Language</i>	4	C
19	211	<i>Reading and Literature</i>	14	
20	215	<i>Reading and Literature</i>	12	B
21	215	<i>Reading and Literature</i>	15	C
22	215	<i>Reading and Literature</i>	15	A
23	215	<i>Reading and Literature</i>	12	B
24	216	<i>Reading and Literature</i>	12	B
25	216	<i>Reading and Literature</i>	12	A
26	216	<i>Reading and Literature</i>	12	B
27	217	<i>Reading and Literature</i>	12	
28	221	<i>Reading and Literature</i>	15	C
29	221	<i>Reading and Literature</i>	8	A
30	221	<i>Reading and Literature</i>	8	C
31	221	<i>Reading and Literature</i>	8	A
32	221	<i>Reading and Literature</i>	13	A
33	221	<i>Reading and Literature</i>	8	A
34	222	<i>Language</i>	4	B
35	222	<i>Language</i>	5	C
36	222	<i>Reading and Literature</i>	8	
37	225	<i>Reading and Literature</i>	16	D
38	225	<i>Reading and Literature</i>	16	D
39	225	<i>Reading and Literature</i>	16	B
40	225	<i>Language</i>	4	C

* Answers are provided here for multiple-choice items only. Sample responses and scoring guidelines for open-response items, which are indicated by shaded cells, will be posted to the Department's Web site later this year.

IX. Mathematics, Grade 3

Grade 3 Mathematics Test

The spring 2007 grade 3 MCAS Mathematics test was based on learning standards in the Massachusetts *Mathematics Curriculum Framework* (2000). The *Framework* identifies five major content strands, listed below. Specific learning standards for grade 3 are found in the *Supplement to the Massachusetts Mathematics Curriculum Framework* (2004). Page numbers for the grades 3–4 *Framework* learning standards and for the grade 3 *Supplement* standards appear in parentheses.

- Number Sense and Operations (*Framework*, pages 22–23; *Supplement*, pages 3–4)
- Patterns, Relations, and Algebra (*Framework*, page 32; *Supplement*, page 4)
- Geometry (*Framework*, page 40; *Supplement*, pages 4–5)
- Measurement (*Framework*, page 48; *Supplement*, page 5)
- Data Analysis, Statistics, and Probability (*Framework*, page 56; *Supplement*, pages 5–6)

The *Mathematics Curriculum Framework* and *Supplement* are available on the Department Web site at www.doe.mass.edu/frameworks/current.html.

In *Test Item Analysis Reports* and on the Subject Area Subscore pages of the *MCAS School Reports* and *District Reports*, Mathematics test results are reported under five MCAS reporting categories, which are identical to the five *Framework* content strands listed above.

Test Sessions

The MCAS grade 3 Mathematics test included two separate test sessions. Each session included multiple-choice, short-answer, and open-response questions.

Reference Materials and Tools

Each student taking the grade 3 Mathematics test was provided with a plastic ruler and a grade 3 Mathematics Tool Kit. A copy of the tool kit follows the final question in this chapter. An image of the ruler is not reproduced in this publication.

The use of bilingual word-to-word dictionaries was allowed for current and former limited English proficient students only, during both Mathematics test sessions. No calculators, other reference tools, or materials were allowed.

Cross-Reference Information

The table at the conclusion of this chapter indicates each item's reporting category and the *Framework* learning standard it assesses. The correct answers for multiple-choice and short-answer questions are also displayed in the table.

Mathematics

SESSION 1

You may use your tool kit and MCAS ruler during this session.
You may **not** use a calculator during this session.



DIRECTIONS

This session contains twelve multiple-choice questions, two short-answer questions, and two open-response questions. For multiple-choice questions, mark your answers by filling in the circle next to the best answer. For the short-answer and open-response questions, write your answer in the space provided below the question.

- 1 Ms. Mackey wrote the number pattern below using the rule “subtract 8.”

187, 179, 171, __?__, 155, 147, 139

What is the missing number in Ms. Mackey’s pattern?

- (A) 163
- (B) 168
- (C) 170
- (D) 177

- 2 The table below shows how many books three classes read.

Books Read

Class	Number of Books
Ms. Potter	1023
Ms. Hogan	?
Mr. Garcia	1067

Ms. Hogan’s class read **more** books than Ms. Potter’s class and **fewer** books than Mr. Garcia’s class.

Which of these could be the number of books Ms. Hogan’s class read?

- (A) 1074
- (B) 1166
- (C) 1005
- (D) 1062

3 What is 972 rounded to the nearest ten?

- (A) 900
- (B) 970
- (C) 980
- (D) 1000

4 Neva has 16 pencils in her desk. Tracy has 8 pencils in her desk.

Which number sentence can be used to find how many more pencils Neva has than Tracy?

- (A) $8 - 16 = \square$
- (B) $8 + 16 = \square$
- (C) $16 + 8 = \square$
- (D) $16 - 8 = \square$

Use shapes R, T, and Z from your tool kit to answer question 5.

5 Which set of four shapes could you use to make the figure below?

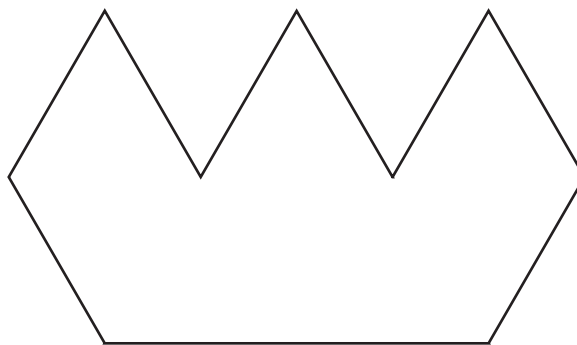

- (A) R, R, T, Z
- (B) R, R, R, Z
- (C) R, R, Z, Z
- (D) R, R, T, T

Question 6 is a short-answer question. Write your answer to this question in the Answer Box provided.

- 6 Mr. Wilson's class made the chart below to show the number of birds that ate at a bird feeder on five days.

Birds That Ate at the Bird Feeder

Day	Number of Birds
Monday	8
Tuesday	18
Wednesday	30
Thursday	12
Friday	20

How many **more** birds ate at the bird feeder on Wednesday than on Monday? Write your answer in the Answer Box below.

Answer Box

6

Write your answer to open-response question 7 in the space provided.

- 7 Zoey is using bananas and oranges to make the pattern shown below. The rule for her pattern is ABBB.

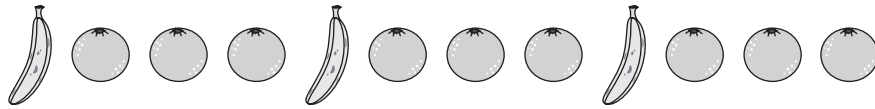

Zoey will follow the rule for her pattern a total of 4 times.

How many **oranges** will Zoey use in all? Show or explain how you got your answer.

Mark your choices for multiple-choice questions 8 through 12 by filling in the circle next to the best answer.

8 Which unit can Sara use to measure the height of the snow in her backyard?

- (A) gallon
- (B) pound
- (C) inch
- (D) ounce

9 Anna has the shapes shown in the box below.

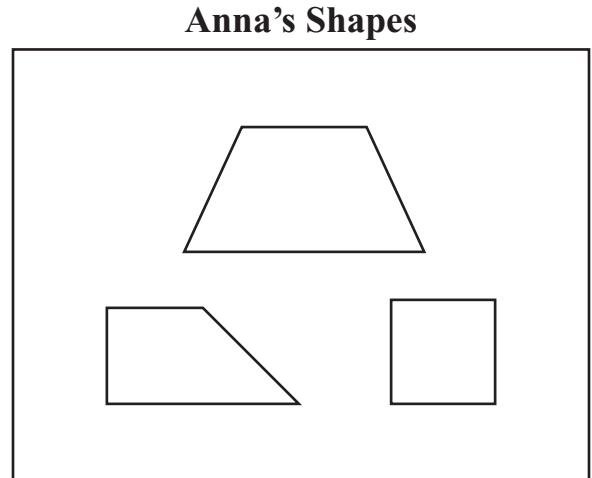

Which sentence best describes Anna's shapes?

- (A) Each shape has all sides of equal length.
- (B) Each shape has one line of symmetry.
- (C) Each shape has four right angles.
- (D) Each shape has four corners.

- 10 Which symbol belongs in the circle below to make a true number sentence?

$$7 \times 7 \bigcirc 34 + 13$$

- (A) >
- (B) -
- (C) <
- (D) =

- 11 Maria is thinking of a number. The clues for her number are shown below.

- It is a multiple of 5.
- It is an even number.
- It is less than 18.

Which of these could be Maria's number?

- (A) 5
- (B) 20
- (C) 8
- (D) 10

- 12 The bar graph below shows the number of students who belong to each club at Patterson School.

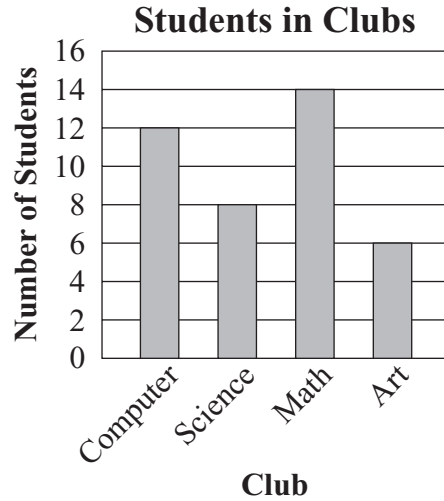

How many **more** students belong to the Math Club than to the Art Club?

- (A) 4
- (B) 6
- (C) 8
- (D) 14

Question 13 is a short-answer question. Write your answer to this question in the Answer Box provided.

- 13 The coats shown below are hanging on coat hooks.

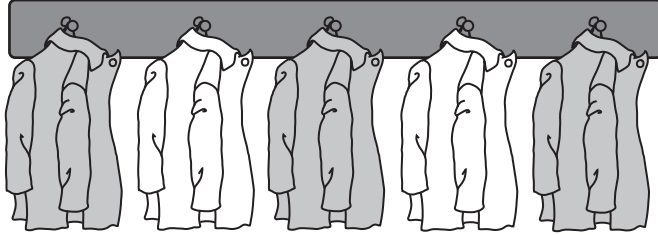

What fraction of the coats are white?

Write your answer in the Answer Box below.

Answer Box

13

Mark your choices for multiple-choice questions 14 and 15 by filling in the circle next to the best answer.

- 14 Brianna bought 4 shirts. Each shirt cost \$8.95.
Which estimate is closest to the total cost of the shirts that Brianna bought?

- | | |
|---|------|
| Ⓐ | \$32 |
| Ⓑ | \$36 |
| Ⓒ | \$38 |
| Ⓓ | \$40 |

- 15 Oliver asked his classmates to vote for their favorite cookie. The tally chart below shows their votes.

Favorite Cookies

Cookie	Number of Classmates
peanut butter	
chocolate chip	
oatmeal	

Which pictograph correctly shows their votes?

Favorite Cookies

(A)

Cookie	Number of Classmates
peanut butter	☺☺☺☺
chocolate chip	☺☺☺
oatmeal	☺☺

Key
☺ stands for 2 classmates

Favorite Cookies

(C)

Cookie	Number of Classmates
peanut butter	☺☺☺☺☺
chocolate chip	☺☺☺☺☺☺☺
oatmeal	☺☺☺☺

Key
☺ stands for 2 classmates

Favorite Cookies

(B)

Cookie	Number of Classmates
peanut butter	☺☺☺☺☺☺
chocolate chip	☺☺☺☺☺☺☺☺
oatmeal	☺☺☺☺

Key
☺ stands for 2 classmates

Favorite Cookies

(D)

Cookie	Number of Classmates
peanut butter	☺☺☺
chocolate chip	☺☺☺☺
oatmeal	☺☺

Key
☺ stands for 2 classmates

Write your answers to parts (a) and (b) of open-response question 16 in the spaces provided.

Use the number tiles from your tool kit to answer question 16.

16 Alan has the number tiles shown below.

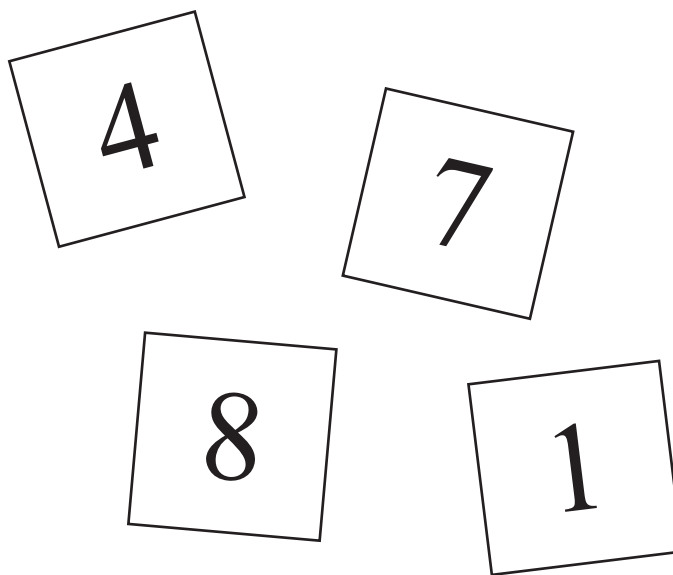

a. Use all of Alan’s number tiles to make the four-digit number with the **smallest** value. Use each number tile only one time. Write the number in the boxes below.

--	--	--	--

b. What is the value of the digit 7 in the number you made? Explain your answer.

Mathematics

SESSION 2

You may use your tool kit and MCAS ruler during this session.
You may **not** use a calculator during this session.



DIRECTIONS

This session contains thirteen multiple-choice questions, three short-answer questions, and three open-response questions. For multiple-choice questions, mark your answers by filling in the circle next to the best answer. For the short-answer and open-response questions, write your answer in the space provided below the question.

- 17 The tally chart below shows the favorite lunches of some students.

Favorite Lunches

Lunch	Number of Students
Taco	
Chicken	
Spaghetti	
Hamburger	
Pizza	

Which two lunches were the favorites of the same number of students?

- (A) taco and spaghetti
- (B) taco and hamburger
- (C) spaghetti and hamburger
- (D) spaghetti and pizza

- 18 Missy wants to put 12 stickers on her paper.

What is one way that she can put 12 stickers on her paper?

- (A) 3 rows of 3 stickers
- (B) 3 rows of 6 stickers
- (C) 4 rows of 2 stickers
- (D) 4 rows of 3 stickers

- 19 The Hamilton family drove 138 miles. The Jefferson family drove 206 miles. Which of these correctly compares the number of miles each family drove?

- (A) $138 < 206$
- (B) $138 + 206$
- (C) $138 = 206$
- (D) $138 > 206$

- 20 Point S is shown on the number line below.

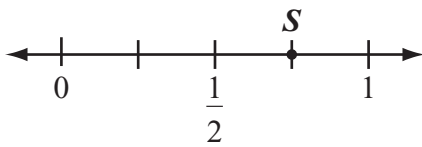

Which fraction best names point S on the number line?

- (A) $\frac{1}{4}$
- (B) $\frac{2}{3}$
- (C) $\frac{3}{4}$
- (D) $\frac{3}{2}$

- 21 Anne made the graph below to show the kinds of shirts worn by her classmates on Wednesday.

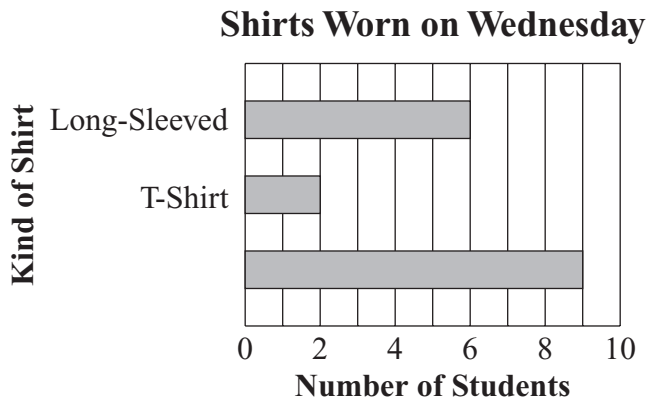

What information is missing from Anne's graph?

- (A) the kind of shirt worn by 9 students
- (B) the kind of shirt worn by 2 students
- (C) the number of students who wore T-shirts
- (D) the number of students who wore long-sleeved shirts

Question 22 is a short-answer question. Write your answer to this question in the Answer Box provided.

22 Compute:

$$\begin{array}{r} 83 \\ \times 4 \\ \hline \end{array}$$

Write your answer in the Answer Box below.

Answer Box

22

Write your answers to parts (a) and (b) of open-response question 23 in the spaces provided.

- 23** The clock below shows the time that Mr. Stone put a cake in the oven.



- a. The cake needs to bake for 30 minutes.

At what time will the cake be done?

- b. Mr. Stone also wants to bake rolls. The rolls only need to bake for 10 minutes.

At what time should Mr. Stone put the rolls in the oven so that they will be done at exactly the same time as the cake?

Mark your choices for multiple-choice questions 24 through 28 by filling in the circle next to the best answer.

- 24 The table below shows how many coins each child in the Jones family has.

Children's Coins

Child	Coins
Byron	3 quarters
Pam	100 pennies
Linda	4 quarters
William	50 pennies

Which two children have the same amount of money?

- (A) Linda and William
- (B) Pam and William
- (C) Byron and Pam
- (D) Pam and Linda

- 25 Jenny collected 10 seashells. She collected 2 times as many seashells as Beth collected.

How many seashells did Beth collect?





- (A) 5
- (B) 8
- (C) 12
- (D) 20

- 26 Which number sentence is true?

- (A) $5 + 0 = 5 \times 1$
- (B) $5 + 1 = 5 \times 1$
- (C) $5 + 0 = 5 \times 0$
- (D) $5 + 1 = 5 \times 0$

- 27 Mandy is going to wrap a gift. The kinds of wrapping paper and bows she can choose are shown below.

Gift Wrap

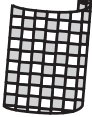
Kinds of Wrapping Paper	Kinds of Bows
	
	
	
	

How many different ways can Mandy choose 1 kind of wrapping paper and 1 kind of bow?

- (A) 2
- (B) 4
- (C) 6
- (D) 8

- 28 Models of Room 1 and Room 2 are shown below. Each room is shaped like a rectangle.

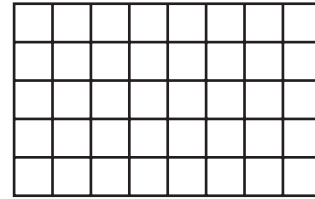

Room 1

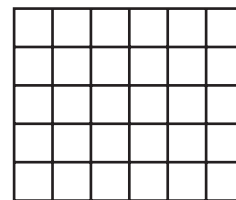

Room 2

 stands for 1 square foot

How many square feet larger is the area of Room 1 than the area of Room 2?

- (A) 2 square feet
- (B) 4 square feet
- (C) 8 square feet
- (D) 10 square feet

Question 29 is a short-answer question. Write your answer to this question in the Answer Box provided.

- 29 A cube is shown below.

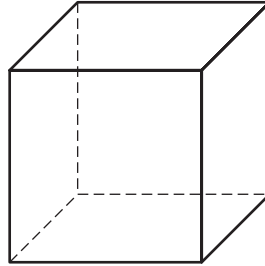

How many corners does a cube have? Write your answer in the Answer Box below.

Answer Box

29

Write your answer to open-response question 30 in the space provided below.

- 30 Noah asked eight of his friends, “How many teeth have you lost?” The chart below shows their answers.

Number of Teeth Lost

Name of Friend	Number of Teeth Lost
Alex	6
Jennifer	8
Kyle	7
Cody	5
Amanda	8
Sammy	7
Dan	9
Sarah	8

Noah started to make the line plot below to show the data from his chart. Put Xs above the correct numbers to complete the line plot.

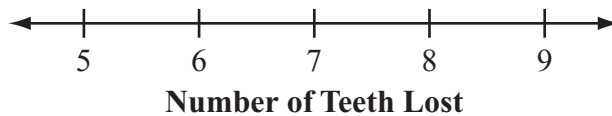

Mark your choices for multiple-choice questions 31 through 33 by filling in the circle next to the best answer.

- 31 Which symbol belongs in the circle below to make the number sentence true?

$$45 \div 9 \bigcirc 35 \div 7$$

- (A) <
- (B) =
- (C) >
- (D) +

- 32 Candace wrote the number sentence below.

$$15 \div 3 = \square$$

Which of these is another way to write Candace's number sentence?

- (A) $15 + \square = 3$
- (B) $15 \times \square = 3$
- (C) $3 + \square = 15$
- (D) $3 \times \square = 15$

- 33 Marta and Nate had the box of 8 candies shown below.

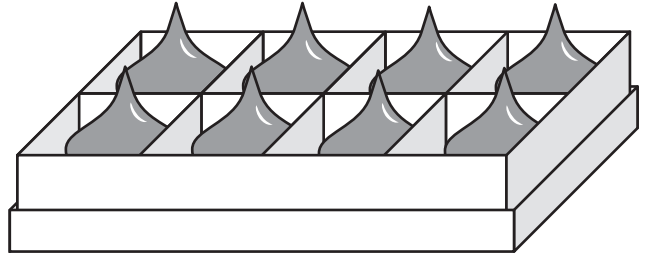

Marta ate $\frac{5}{8}$ of the candies. Nate ate $\frac{2}{8}$ of the candies. Altogether, what fraction of the box of candies did they eat?

- (A) $\frac{3}{8}$
- (B) $\frac{7}{8}$
- (C) $\frac{3}{16}$
- (D) $\frac{7}{16}$

Question 34 is a short-answer question. Write your answer to this question in the Answer Box provided.

- 34 Cindy wrote the number sentence below.

$$\boxed{?} \times 3 = 24$$

In the Answer Box below, write the missing number that makes Cindy's number sentence true.

Answer Box

34

Write your answers to parts (a) and (b) of open-response question 35 in the spaces provided.

Use shapes H, X, and Z from your tool kit to answer question 35.

35 Ravi is using the shapes shown below to learn about symmetry.

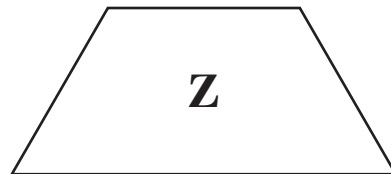
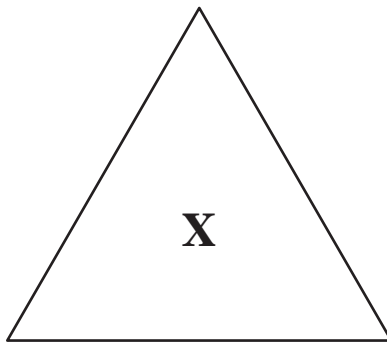
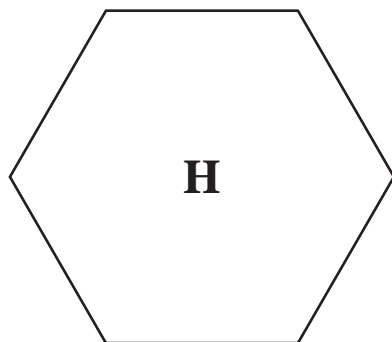

a. In the space below, trace the shape that has **only one** line of symmetry.

b. Draw the line of symmetry onto the shape you traced in part (a).

Massachusetts Comprehensive Assessment System

Grade 3 Mathematics Tool Kit

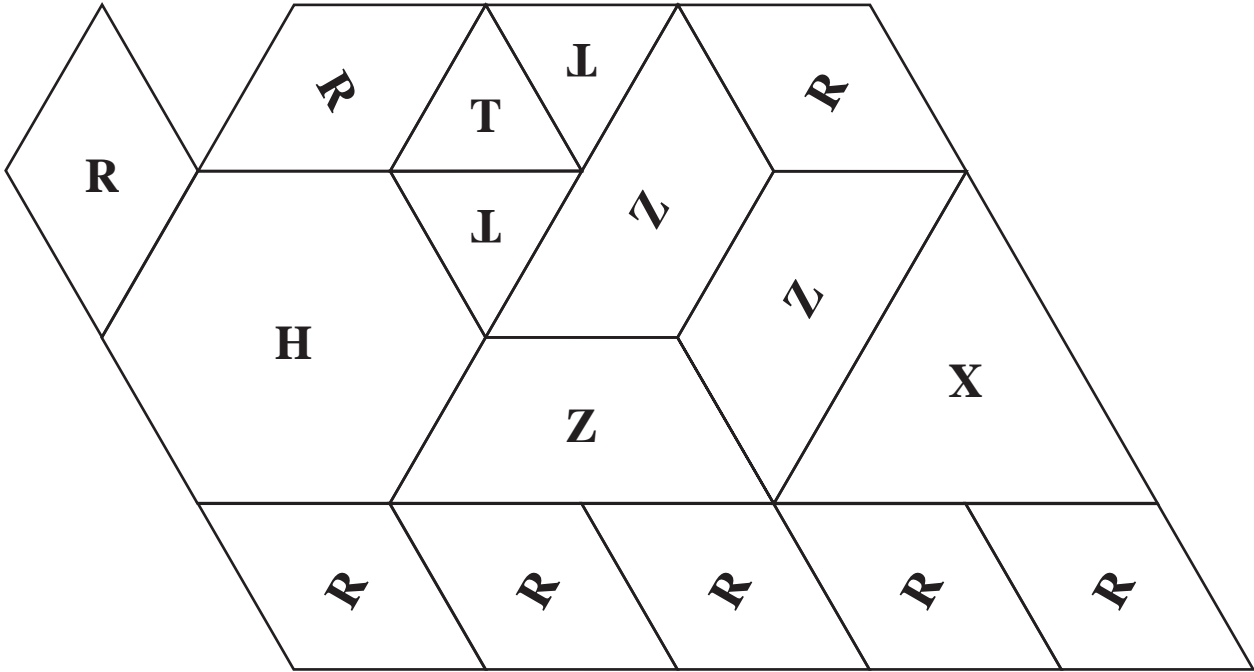

0	1	2	3	4
5	6	7	8	9

Grade 3 Mathematics
Spring 2007 Released Items:
Reporting Categories, Standards, and Correct Answers

Item No.	Page No.	Reporting Category	Standard	Correct Answer (MC/SA)*
1	229	<i>Patterns, Relations, and Algebra</i>	3.P.1	A
2	229	<i>Number Sense and Operations</i>	3.N.2	D
3	230	<i>Number Sense and Operations</i>	3.N.11	B
4	230	<i>Patterns, Relations, and Algebra</i>	3.P.4	D
5	230	<i>Geometry</i>	3.G.7	A
6	231	<i>Data Analysis, Statistics, and Probability</i>	3.D.3	22
7	232	<i>Patterns, Relations, and Algebra</i>	3.P.1	
8	233	<i>Measurement</i>	3.M.1	C
9	233	<i>Geometry</i>	3.G.1	D
10	234	<i>Patterns, Relations, and Algebra</i>	3.P.2	A
11	234	<i>Number Sense and Operations</i>	3.N.5	D
12	234	<i>Data Analysis, Statistics, and Probability</i>	3.D.3	C
13	235	<i>Number Sense and Operations</i>	3.N.3	$\frac{2}{5}$
14	236	<i>Number Sense and Operations</i>	3.N.12	B
15	237	<i>Data Analysis, Statistics, and Probability</i>	3.D.2	D
16	238	<i>Number Sense and Operations</i>	3.N.1	
17	239	<i>Data Analysis, Statistics, and Probability</i>	3.D.3	B
18	239	<i>Number Sense and Operations</i>	3.N.9	D
19	239	<i>Patterns, Relations, and Algebra</i>	3.P.4	A
20	240	<i>Number Sense and Operations</i>	3.N.4	C
21	240	<i>Data Analysis, Statistics, and Probability</i>	3.D.1	A
22	241	<i>Number Sense and Operations</i>	3.N.10	332
23	242	<i>Measurement</i>	3.M.3	
24	243	<i>Measurement</i>	3.M.2	D
25	243	<i>Number Sense and Operations</i>	3.N.8	A
26	243	<i>Number Sense and Operations</i>	3.N.7	A
27	244	<i>Data Analysis, Statistics, and Probability</i>	3.D.4	D
28	244	<i>Measurement</i>	3.M.4	D
29	245	<i>Geometry</i>	3.G.2	8
30	246	<i>Data Analysis, Statistics, and Probability</i>	3.D.3	
31	247	<i>Patterns, Relations, and Algebra</i>	3.P.2	B
32	247	<i>Number Sense and Operations</i>	3.N.6	D
33	247	<i>Number Sense and Operations</i>	3.N.13	B
34	248	<i>Patterns, Relations, and Algebra</i>	3.P.3	8
35	249	<i>Geometry</i>	3.G.6	

* Answers are provided here for multiple-choice items and short-answer items only. Sample responses and scoring guidelines for open-response items, which are indicated by shaded cells, will be posted to the Department's Web site later this year.

X. Mathematics, Grade 4

Grade 4 Mathematics Test

The spring 2007 grade 4 MCAS Mathematics test was based on learning standards in the Massachusetts *Mathematics Curriculum Framework* (2000). The *Framework* identifies five major content strands, listed below. Page numbers for the grades 3–4 learning standards appear in parentheses.

- Number Sense and Operations (*Framework*, pages 22–23)
- Patterns, Relations, and Algebra (*Framework*, page 32)
- Geometry (*Framework*, page 40)
- Measurement (*Framework*, page 48)
- Data Analysis, Statistics, and Probability (*Framework*, page 56)

The *Mathematics Curriculum Framework* is available on the Department Web site at www.doe.mass.edu/frameworks/current.html.

In *Test Item Analysis Reports* and on the Subject Area Subscore pages of the *MCAS School Reports* and *District Reports*, Mathematics test results are reported under five MCAS reporting categories, which are identical to the five *Framework* content strands listed above.

Test Sessions

The MCAS grade 4 Mathematics test included two separate test sessions. Each session included multiple-choice, short-answer, and open-response questions.

Reference Materials and Tools

Each student taking the grade 4 Mathematics test was provided with a plastic ruler and a grade 4 Mathematics Tool Kit. A copy of the tool kit follows the final question in this chapter. An image of the ruler is not reproduced in this publication.

The use of bilingual word-to-word dictionaries was allowed for current and former limited English proficient students only, during both Mathematics test sessions. No calculators, other reference tools, or materials were allowed.

Cross-Reference Information

The table at the conclusion of this chapter indicates each item's reporting category and the *Framework* learning standard it assesses. The correct answers for multiple-choice and short-answer questions are also displayed in the table.

Mathematics

SESSION 1

You may use your tool kit and MCAS ruler during this session.
You may **not** use a calculator during this session.



DIRECTIONS

This session contains twelve multiple-choice questions, two short-answer questions, and three open-response questions. Mark your answers to these questions in the spaces provided in your Student Answer Booklet.

- 1 Which of the following squares has $\frac{3}{5}$ shaded?

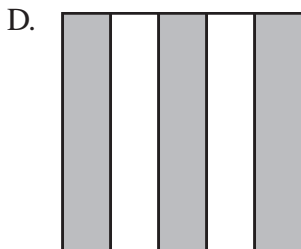
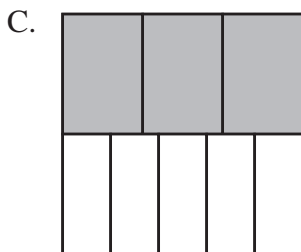
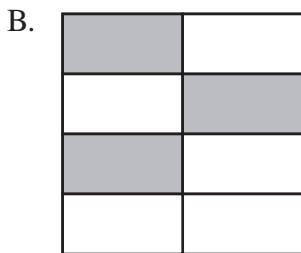
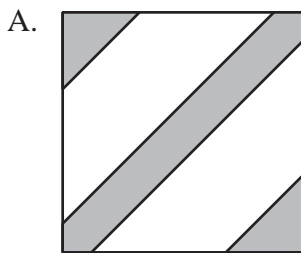

- 2 Karen has only \$10 bills and \$1 bills in her wallet. She made the table below to show how much money she has.

Karen's Money

Type of Bill	Number of Bills
\$10 bill	11
\$ 1 bill	7

Based on the table, how much money does Karen have in her wallet?

- A. \$1107
B. \$117
C. \$107
D. \$17

- 3 Which of the following is the **best** way for Mr. Gomez to show the change in the average temperature each day?
- A. a line graph
 - B. a tally chart
 - C. a pictograph
 - D. a circle graph

- 4 Tamika made a model of a house, as shown below, by gluing together a cube and a square pyramid.

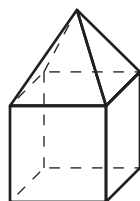

How many faces does the model of the house have?

- A. 4
- B. 8
- C. 9
- D. 11

- 5 Last summer, Max earned 5 stickers for every book he read. He earned 40 stickers in all for reading books. Which number sentence could be used to find b , the number of books Max read?
- A. $b \div 5 = 40$
 - B. $5 + b = 40$
 - C. $b - 5 = 40$
 - D. $5 \times b = 40$

- 6 All of the numbers Cindy wrote in the box shown below are even numbers **and** multiples of 3.

6	36
12	24

Which of the following is also an even number **and** a multiple of 3?

- A. 13
- B. 21
- C. 26
- D. 30

- 7 Last month, 3801 people ate at Tony’s Pizza. This month, 2765 people ate at Tony’s Pizza.

How many more people ate at Tony’s Pizza last month than this month?

- A. 1036
- B. 1044
- C. 1146
- D. 1164

- 8 The table below shows the amounts of money needed to park for different numbers of minutes. Each 6 minutes costs the same amount of money.

Parking Amounts

Amount of Money	Time (in minutes)
5 cents	6
10 cents	12
15 cents	18
20 cents	24
25 cents	30

How much money will it cost to park for 60 minutes?

- A. 50 cents
- B. 55 cents
- C. 65 cents
- D. 72 cents

- 9 Ms. Rodriguez is going to make 8 bows. She needs 28 inches of ribbon to make each bow.

Which of the following expressions has a value that is **closest** to the amount of ribbon, in inches, Ms. Rodriguez will need?

- A. 5×20
- B. 8×20
- C. 8×30
- D. 10×30

Question 10 is an open-response question.

- **BE SURE TO ANSWER AND LABEL ALL PARTS OF THE QUESTION.**
- **Show all your work (diagrams, tables, or computations) in your Student Answer Booklet.**
- **If you do the work in your head, explain in writing how you did the work.**

Write your answer to question 10 in the space provided in your Student Answer Booklet.

- 10 The chart below shows the numbers of books four children read during July.

Books Read in July

Child	Number of Books
Joy	15
Mike	6
Carol	9
Randy	12

- a. What is the total number of books the four children read during July? Show your work or explain how you got your answer.
- b. In your Student Answer Booklet, create a pictograph that displays the information from the chart. Be sure to include a title, correct labels, and a key for your pictograph. Your key must **not** represent only 1 book.

Questions 11 and 12 are short-answer questions. Write your answers to these questions in the boxes provided in your Student Answer Booklet. Do not write your answers in this test booklet. You may do your figuring in the test booklet.

- 11 Angelina wrote the number pattern below.

101, 122, 143, 164, 185, ?

She adds the same number each time to find the next number in the pattern.

What is the next number in Angelina's pattern?

- 12 Compute:

$$651 \div 3$$

Question 13 is an open-response question.



- **BE SURE TO ANSWER AND LABEL ALL PARTS OF THE QUESTION.**
- **Show all your work (diagrams, tables, or computations) in your Student Answer Booklet.**
- **If you do the work in your head, explain in writing how you did the work.**

Write your answer to question 13 in the space provided in your Student Answer Booklet.

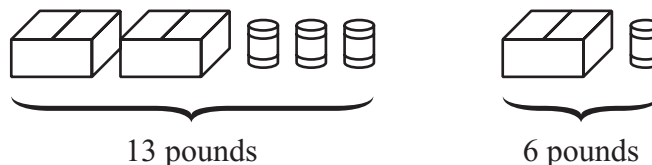
13 Ms. Lin made the models shown below.

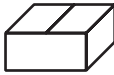

Each  has the same weight. Each  has the same weight.

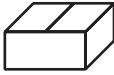
- What is the weight, in pounds, of 1 ? Show your work or explain how you got your answer.
- What is the weight, in pounds, of 1 ? Show your work or explain how you got your answer.
- What is the **least** number of  and  that have a total weight of 21 pounds? Show your work or explain how you got your answer.

Mark your answers to multiple-choice questions 14 through 16 in the spaces provided in your Student Answer Booklet. Do not write your answers in this test booklet. You may do your figuring in the test booklet.

- 14 Rhonda put the cards shown below into an empty bag and mixed them up. The back of each card is blank.

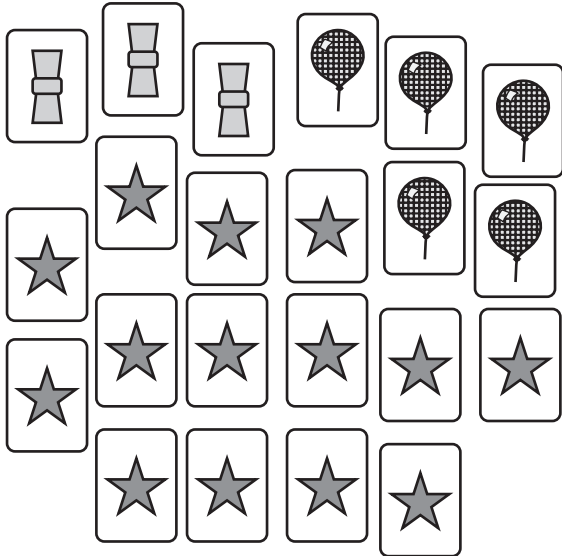

If Rhonda picks 1 card without looking, which of the following best describes the chances that she will pick a card with a star on it?

- A. certain
- B. likely
- C. unlikely
- D. impossible

- 15 Elin has centimeter blocks like the one shown below.

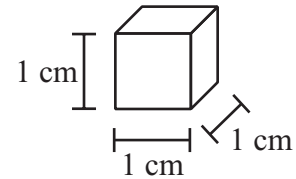

She also has a box with the length, width, and height shown below.

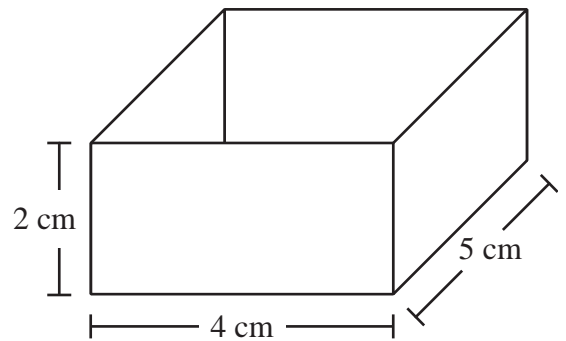

Which of the following is best represented by Elin filling the box with centimeter blocks?

- A. the area of the box
- B. the perimeter of the box
- C. the weight of the box
- D. the volume of the box

- 16 The table below shows the number of buttons that were made at a button factory each week for three weeks.

Buttons Made

Week	Number of Buttons
Week 1	84,503
Week 2	80,968
Week 3	84,551

Which of the following shows the weeks in order from the week with the **greatest** number of buttons made to the week with the **least** number of buttons made?

- A. Week 1, Week 3, Week 2
- B. Week 2, Week 3, Week 1
- C. Week 2, Week 1, Week 3
- D. Week 3, Week 1, Week 2

Question 17 is an open-response question.

- **BE SURE TO ANSWER AND LABEL ALL PARTS OF THE QUESTION.**
- **Show all your work (diagrams, tables, or computations) in your Student Answer Booklet.**
- **If you do the work in your head, explain in writing how you did the work.**

Write your answer to question 17 in the space provided in your Student Answer Booklet.

17 Jason drew a closed shape with the properties listed below.

- It has exactly four angles.
 - All angles are right angles.
 - Opposite sides are congruent.
 - Opposite sides are parallel.
- a. On the grid in your Student Answer Booklet, draw a shape that has the same properties as Jason's shape.
- b. On the grid in your Student Answer Booklet, draw a **different** shape that also has the same properties as Jason's shape.

Jason also drew trapezoid X shown on the grid below.

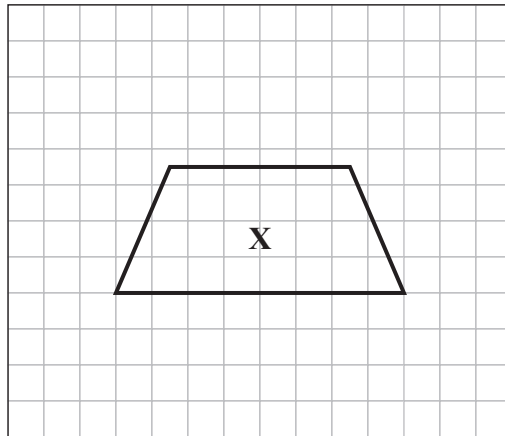

- c. List 3 properties of trapezoid X.

Mathematics

SESSION 2

You may use your tool kit and MCAS ruler during this session.
You may **not** use a calculator during this session.



DIRECTIONS

This session contains seventeen multiple-choice questions, three short-answer questions, and two open-response questions. Mark your answers to these questions in the spaces provided in your Student Answer Booklet.

- 18 Pat made the cakes shown below for a bake sale.

Chocolate Cake

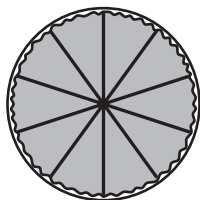

Vanilla Cake

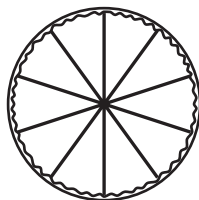

She sold $\frac{9}{10}$ of the chocolate cake and $\frac{6}{10}$ of the vanilla cake.

Which of the following fractions shows how much **more** chocolate cake was sold than vanilla cake?

- A. $\frac{2}{10}$
- B. $\frac{3}{10}$
- C. $\frac{4}{10}$
- D. $\frac{5}{10}$

- 19 Which of the following shapes has **only** acute angles?

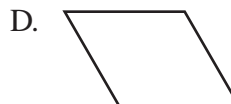
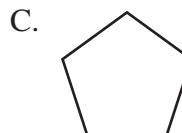

- 20 Which of the following does **not** equal 1500?
- A. 3×500
 - B. 300×5
 - C. 30×50
 - D. 300×50

- 21 Ryan picked 6 of the flowers shown below.

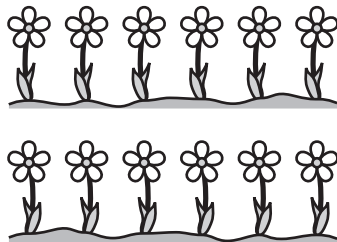

He correctly wrote two fractions to represent the part of the group of flowers he picked.

Which two fractions could Ryan have written?

- A. $\frac{1}{2}$ and $\frac{6}{12}$
- B. $\frac{6}{12}$ and $\frac{1}{6}$
- C. $\frac{1}{2}$ and $\frac{4}{6}$
- D. $\frac{6}{12}$ and $\frac{2}{3}$

- 22 Which of the following shows the number 0.45 written in words?
- A. forty-five
 - B. four and five tenths
 - C. four and five hundredths
 - D. forty-five hundredths

- 23 Kyle put 50 pickles on 10 sandwiches. He put the same number of pickles on each sandwich.

Which of the following number sentences can be used to find how many pickles Kyle put on each sandwich?

- A. $50 - 10 = \square$
- B. $50 \times 10 = \square$
- C. $50 + 10 = \square$
- D. $50 \div 10 = \square$

- 24 Jamie made the line graph below to show how much money he earned shoveling snow each week for five weeks.

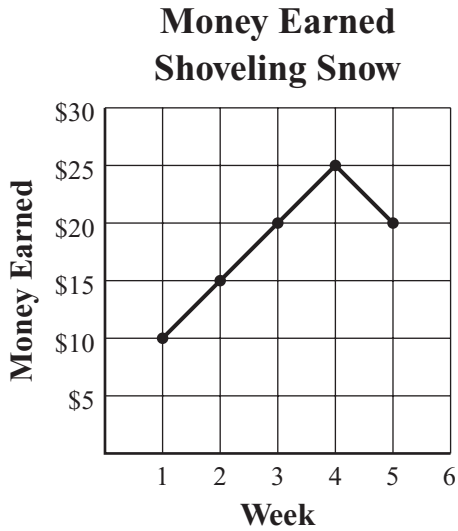

Based on the information in the graph, which of the following statements is true?

- A. Most weeks Jamie earned more money than the week before.
- B. Each week Jamie earned more money than the week before.
- C. Most weeks Jamie earned less money than the week before.
- D. Each week Jamie earned less money than the week before.

- 25 The total cost of 2 pencils is 30¢. Each pencil costs the same amount. What is the total cost of 3 pencils?

- A. 15¢
- B. 33¢
- C. 45¢
- D. 90¢

- 26 Jake is 52 inches tall. Which of the following measurements is the same as 52 inches?



- A. 4 feet 2 inches
- B. 4 feet 4 inches
- C. 5 feet 2 inches
- D. 5 feet 4 inches

Question 27 is an open-response question.

- **BE SURE TO ANSWER AND LABEL ALL PARTS OF THE QUESTION.**
- **Show all your work (diagrams, tables, or computations) in your Student Answer Booklet.**
- **If you do the work in your head, explain in writing how you did the work.**

Write your answer to question 27 in the space provided in your Student Answer Booklet.

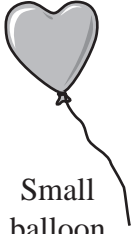
- 27 At The Village Gift Shop, balloons are sold in two different sizes. The picture below shows the cost of each size of balloon.

 Small balloon \$1.25	 Large balloon \$2.99
Prices include tax.	

- a. Kiki is buying 2 small balloons and 1 large balloon. What is the total cost of her three balloons at The Village Gift Shop? Show your work or explain how you got your answer.
- b. Kiki gave the clerk \$6 to pay for her three balloons. How much change should Kiki receive? Show your work or explain how you got your answer.
- c. Sam has \$10 to buy balloons at The Village Gift Shop. He will follow all of the rules listed below to choose his balloons.
 - He will buy at least one of each size of balloon.
 - He will buy as many balloons as he can.
 - He will spend as close to \$10 as he can without going over.

Using his rules, how many small balloons and large balloons can Sam buy for \$10? Show your work or explain how you got your answer.

Questions 28 and 29 are short-answer questions. Write your answers to these questions in the boxes provided in your Student Answer Booklet. Do not write your answers in this test booklet. You may do your figuring in the test booklet.

28 The line plot below shows the shoe sizes of all the students in Ms. Hill’s class.

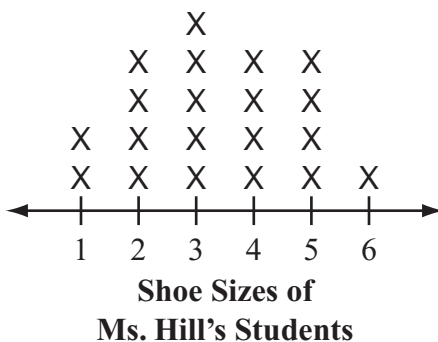

How many students in Ms. Hill’s class have a shoe size **larger** than 4?

29 Ms. Chan bought 15 shirts. Each shirt cost \$18, including tax. What was the total cost of the shirts?

Question 30 is a short-answer question. Write your answer to this question in the box provided in your Student Answer Booklet. Do not write your answer in this test booklet. You may do your figuring in the test booklet.

- 30 Pedro wrote the number sentences below.

$$36 = \square \times 4$$

$$\square \times \triangle = 18$$

The value of \square is the same in both sentences. Both of Pedro's number sentences are true. What is the value of \triangle ?

Question 31 is an open-response question.

- **BE SURE TO ANSWER AND LABEL ALL PARTS OF THE QUESTION.**
- **Show all your work (diagrams, tables, or computations) in your Student Answer Booklet.**
- **If you do the work in your head, explain in writing how you did the work.**

Write your answer to question 31 in the space provided in your Student Answer Booklet.

- 31 Three classes will go to the book fair at Carter Elementary School. The first class will arrive at the book fair at the time shown on the clock below.



- a. At what time will the first class arrive at the book fair?

Each class will spend 30 minutes at the book fair and then leave. The second class will arrive at the book fair as the first class leaves, and the third class will arrive as the second class leaves.

- b. What is the total amount of time that all three classes will spend at the book fair? Show or explain how you got your answer.
- c. What time will it be when the third class **leaves** the book fair? Show or explain how you got your answer.

Mark your answers to multiple-choice questions 32 through 39 in the spaces provided in your Student Answer Booklet. Do not write your answers in this test booklet. You may do your figuring in the test booklet.

- 32 Ms. Wang has the pencils shown below in her desk.

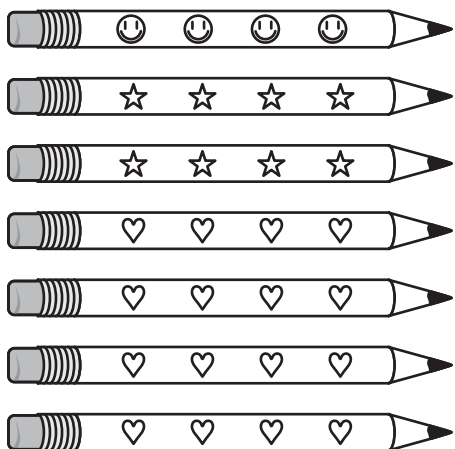

She took one pencil out of her desk without looking.

What is the probability that Ms. Wang took out a pencil with stars on it?

- A. 1 out of 3
- B. 1 out of 7
- C. 2 out of 5
- D. 2 out of 7

- 33 Rosetta will cut the paper shape shown below in a straight line from point X to point Y.

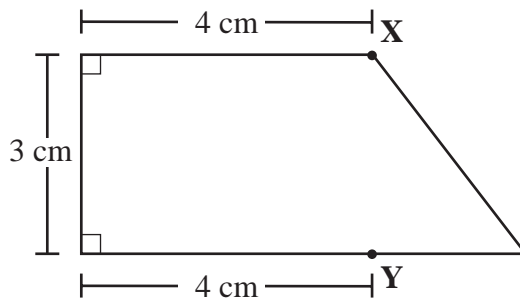

What two shapes will Rosetta have after she cuts the paper?

- A. a square and a triangle
- B. a square and a trapezoid
- C. a rectangle and a triangle
- D. a rectangle and a parallelogram

- 34 The manager of a ball factory made the table below to show the number of balls that were made at the factory each day for two weeks.

**Balls Made at Ball Factory
for Two Weeks**

Day	Number of Balls Made First Week	Number of Balls Made Second Week
Monday	1765	1816
Tuesday	1740	1794
Wednesday	1698	1750
Thursday	1542	1675
Friday	1505	1610

Based on the information in the table, which of the following is true about the number of balls made each day for these two weeks?

- A. The same number of balls were made each day.
- B. The least number of balls were made at the end of the second week.
- C. More balls were made at the end of each week than at the beginning of each week.
- D. More balls were made at the beginning of each week than at the end of each week.

- 35 Last week, 228 fourth-grade students rode 4 buses on a field trip. The same number of students rode on each bus.

How many students rode on each bus?

- A. 52
- B. 57
- C. 62
- D. 67

- 36 Shannon made the map below to show the towns on Pine Island.

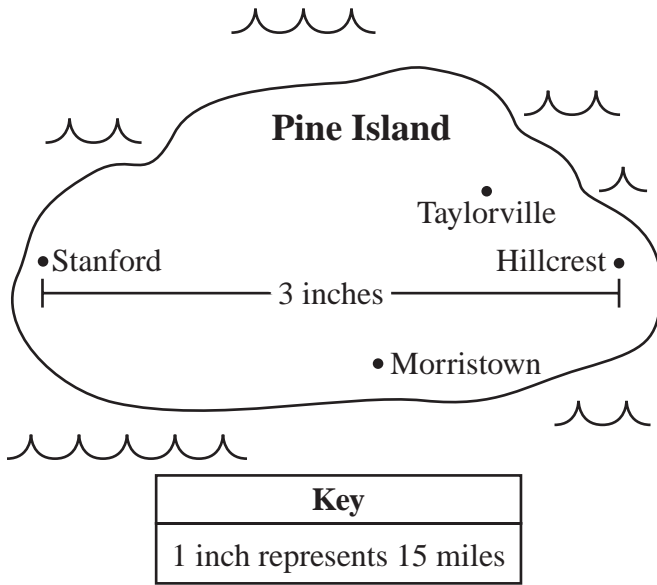

She marked the distance, in inches, between Stanford and Hillcrest on the map.

About how many miles is Stanford from Hillcrest?

- A. 15
- B. 30
- C. 35
- D. 45

- 37 Rachel wants to decorate her journal with stickers. She decided to choose 1 animal, 1 flower, and 1 heart from each of the sticker groups shown below.

Sticker Groups

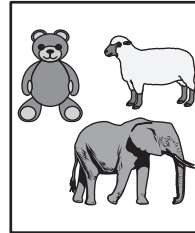

Animals



Flowers

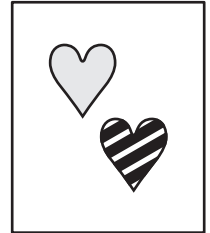

Hearts

What is the total number of different combinations of 1 animal, 1 flower, and 1 heart that Rachel can choose?

- A. 8
- B. 9
- C. 11
- D. 18

- 38 The table below shows the different numbers of boxes that are needed to hold different numbers of jars. Each box holds the same number of jars.

Jars in Boxes

Number of Jars	Number of Boxes
12	2
18	3
24	4
30	5
36	6
42	7

How many jars does each box hold?

- A. 6
- B. 8
- C. 10
- D. 12

- 39 Which of the following decimal numbers is equivalent to $\frac{6}{10}$?

- A. 0.06
- B. 0.6
- C. 6.0
- D. 6.10

Massachusetts Comprehensive Assessment System Grade 4 Mathematics Tool Kit

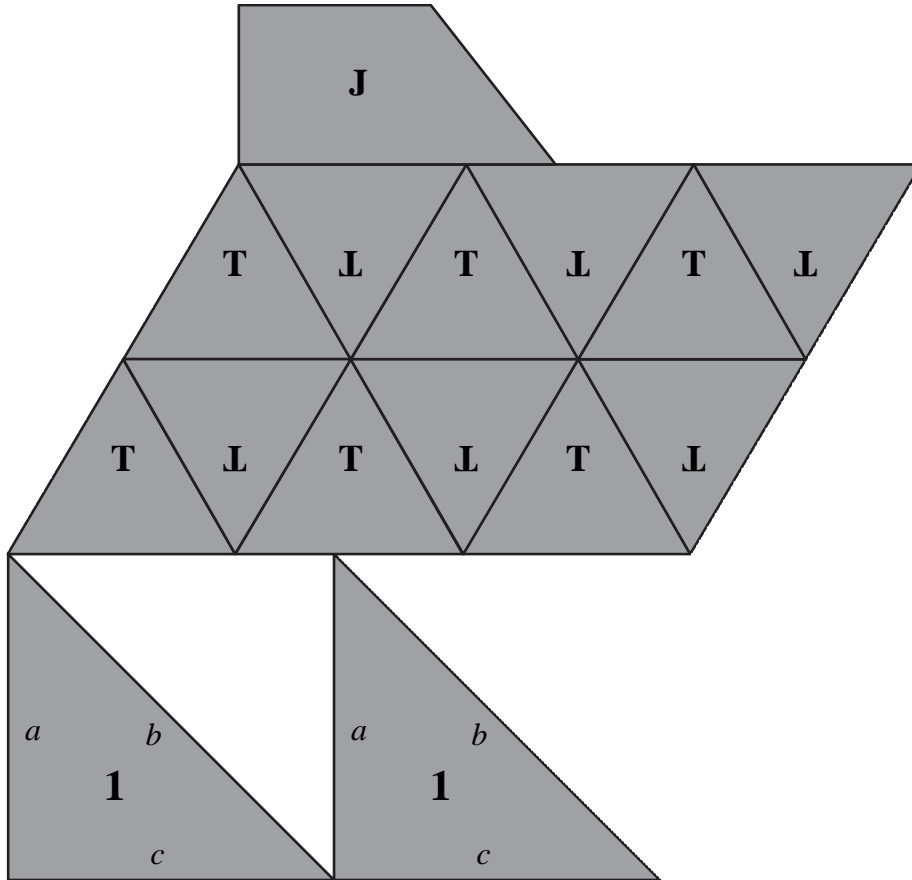

Grade 4 Mathematics
Spring 2007 Released Items:
Reporting Categories, Standards, and Correct Answers

Item No.	Page No.	Reporting Category	Standard	Correct Answer (MC/SA)*
1	255	<i>Number Sense and Operations</i>	4.N.3	D
2	255	<i>Number Sense and Operations</i>	4.N.1	B
3	256	<i>Data Analysis, Statistics, and Probability</i>	4.D.1	A
4	256	<i>Geometry</i>	4.G.1	C
5	256	<i>Patterns, Relations, and Algebra</i>	4.P.2	D
6	256	<i>Number Sense and Operations</i>	4.N.7	D
7	257	<i>Number Sense and Operations</i>	4.N.10	A
8	257	<i>Patterns, Relations, and Algebra</i>	4.P.6	A
9	257	<i>Number Sense and Operations</i>	4.N.17	C
10	258	<i>Data Analysis, Statistics, and Probability</i>	4.D.3	
11	259	<i>Patterns, Relations, and Algebra</i>	4.P.1	206
12	259	<i>Number Sense and Operations</i>	4.N.13	217
13	260	<i>Patterns, Relations, and Algebra</i>	4.P.4	
14	261	<i>Data Analysis, Statistics, and Probability</i>	4.D.6	B
15	261	<i>Measurement</i>	4.M.1	D
16	262	<i>Number Sense and Operations</i>	4.N.2	D
17	263	<i>Geometry</i>	4.G.2	
18	264	<i>Number Sense and Operations</i>	4.N.18	B
19	264	<i>Geometry</i>	4.G.4	B
20	265	<i>Number Sense and Operations</i>	4.N.11	D
21	265	<i>Number Sense and Operations</i>	4.N.4	A
22	265	<i>Number Sense and Operations</i>	4.N.6	D
23	265	<i>Number Sense and Operations</i>	4.N.10	D
24	266	<i>Data Analysis, Statistics, and Probability</i>	4.D.3	A
25	266	<i>Patterns, Relations, and Algebra</i>	4.P.5	C
26	266	<i>Measurement</i>	4.M.2	B
27	267	<i>Number Sense and Operations</i>	4.N.10	
28	268	<i>Data Analysis, Statistics, and Probability</i>	4.D.3	5
29	268	<i>Number Sense and Operations</i>	4.N.10	\$270
30	269	<i>Patterns, Relations, and Algebra</i>	4.P.3	2
31	270	<i>Measurement</i>	4.M.3	
32	271	<i>Data Analysis, Statistics, and Probability</i>	4.D.4	D
33	271	<i>Geometry</i>	4.G.9	C
34	272	<i>Data Analysis, Statistics, and Probability</i>	4.D.3	D
35	272	<i>Number Sense and Operations</i>	4.N.13	B
36	273	<i>Patterns, Relations, and Algebra</i>	4.P.5	D
37	273	<i>Data Analysis, Statistics, and Probability</i>	4.D.5	D
38	274	<i>Patterns, Relations, and Algebra</i>	4.P.1	A
39	274	<i>Number Sense and Operations</i>	4.N.5	B

* Answers are provided here for multiple-choice items and short-answer items only. Sample responses and scoring guidelines for open-response items, which are indicated by shaded cells, will be posted to the Department's Web site later this year.

XI. Mathematics, Grade 5

Grade 5 Mathematics Test

The spring 2007 grade 5 MCAS Mathematics test was based on learning standards in the Massachusetts *Mathematics Curriculum Framework* (2000). The *Framework* identifies five major content strands, listed below. Specific learning standards for grade 5 are found in the *Supplement to the Massachusetts Mathematics Curriculum Framework* (2004). Page numbers for the grades 5–6 *Framework* learning standards and for the grade 5 *Supplement* standards appear in parentheses.

- Number Sense and Operations (*Framework*, pages 25–26; *Supplement*, pages 7–8)
- Patterns, Relations, and Algebra (*Framework*, page 34; *Supplement*, page 8)
- Geometry (*Framework*, page 42; *Supplement*, page 9)
- Measurement (*Framework*, page 50; *Supplement*, pages 9–10)
- Data Analysis, Statistics, and Probability (*Framework*, page 58; *Supplement*, page 10)

The *Mathematics Curriculum Framework* and *Supplement* are available on the Department Web site at www.doe.mass.edu/frameworks/current.html.

In *Test Item Analysis Reports* and on the Subject Area Subscore pages of the *MCAS School Reports* and *District Reports*, Mathematics test results are reported under five MCAS reporting categories, which are identical to the five *Framework* content strands listed above.

Test Sessions

The MCAS grade 5 Mathematics test included two separate test sessions. Each session included multiple-choice, short-answer, and open-response questions.

Reference Materials and Tools

Each student taking the grade 5 Mathematics test was provided with a plastic ruler and a grade 5 Mathematics Reference Sheet. A copy of the reference sheet follows the final question in this chapter. An image of the ruler is not reproduced in this publication.

The use of bilingual word-to-word dictionaries was allowed for current and former limited English proficient students only, during both Mathematics test sessions. No calculators, other reference tools, or materials were allowed.

Cross-Reference Information

The table at the conclusion of this chapter indicates each item's reporting category and the *Framework* learning standard it assesses. The correct answers for multiple-choice and short-answer questions are also displayed in the table.

Mathematics

SESSION 1

You may use your reference sheet and MCAS ruler during this session.
*You may **not** use a calculator during this session.*



DIRECTIONS

This session contains twelve multiple-choice questions, two short-answer questions, and three open-response questions. Mark your answers to these questions in the spaces provided in your Student Answer Booklet.

- 1 Ramon wrote the pattern shown below.

6, 18, 30, 42, 54, . . .

Which of the following is a rule for Ramon's pattern?

- A. add 6
- B. add 12
- C. multiply by 3
- D. multiply by 6

- 2 At one time the population of Massachusetts was about 6,349,100. What digit is in the hundred thousands place of this number?

- A. 1
- B. 3
- C. 4
- D. 6

3 In which of the following diagrams does Figure 2 appear to be a reflection of Figure 1 across line m ?

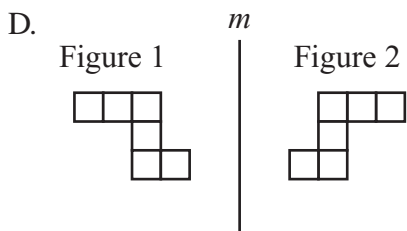
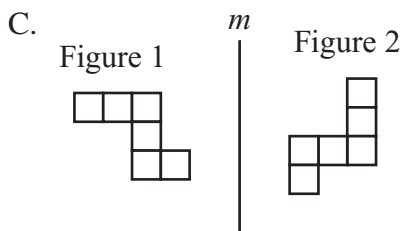
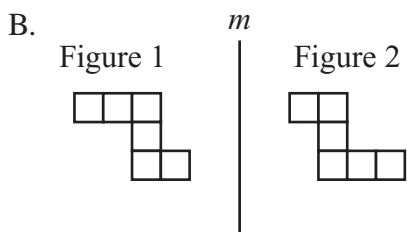
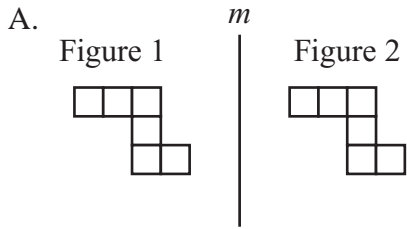

4 A plumber spent 0.5 hours repairing a faucet. Which of the following fractions is **not** equivalent to 0.5?

- A. $\frac{1}{2}$
- B. $\frac{2}{4}$
- C. $\frac{3}{5}$
- D. $\frac{5}{10}$

5 In triangle PQR , shown below, angle P measures 140° .

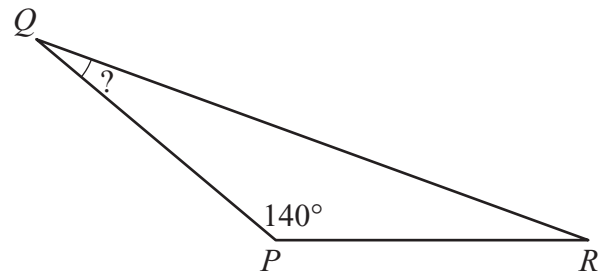

Angle Q has the same measure as angle R . What is the measure of angle Q ?

- A. 20°
- B. 40°
- C. 70°
- D. 80°

- 6 Carla set up tables and chairs for a party. There were four chairs at each table.

Carla set up n tables. If n represents any number of tables, which of the following expressions represents the total number of chairs that Carla set up?

- A. $n \div 4$
- B. $4 \div n$
- C. $n + 4$
- D. $4 \times n$

- 7 Kevin has the following three kinds of juice boxes in a cooler.

- 12 apple juice
- 13 grape juice
- 15 orange juice

The juice boxes are all the same size and shape. Kevin will take out a juice box without looking.

What is the probability that Kevin will take out an apple juice box?

- A. $\frac{1}{40}$
- B. $\frac{1}{12}$
- C. $\frac{12}{40}$
- D. $\frac{12}{28}$

- 8 Greg recorded the heights of four plants. The heights are listed in the table below.

Plant Heights

Plant	Height (inches)
A	$5\frac{1}{2}$ inches
B	$5\frac{3}{8}$ inches
C	$5\frac{1}{4}$ inches
D	$5\frac{7}{16}$ inches

Which plant had the **greatest** height?

- A. Plant A
- B. Plant B
- C. Plant C
- D. Plant D

- 9 To make hot cereal, Macy uses the directions on the back of the cereal box, as shown in the table below.

Directions for Making Hot Cereal

Number of Servings of Hot Cereal	Dry Cereal Needed	Water Needed
1	$\frac{1}{4}$ cup	1 cup
2	$\frac{1}{2}$ cup	2 cups
3	$\frac{3}{4}$ cup	3 cups
4	1 cup	4 cups

Macy wants to make 10 servings of hot cereal. Using this table, what is the total number of cups of dry cereal that she should use?

- A. $1\frac{1}{4}$ cups
- B. $2\frac{1}{2}$ cups
- C. 5 cups
- D. 10 cups

Question 10 is an open-response question.

- **BE SURE TO ANSWER AND LABEL ALL PARTS OF THE QUESTION.**
- **Show all your work (diagrams, tables, or computations) in your Student Answer Booklet.**
- **If you do the work in your head, explain in writing how you did the work.**

Write your answer to question 10 in the space provided in your Student Answer Booklet.

- 10** Three candidates ran in the election for fifth-grade class president. The bar graph below shows the number of students who voted for each candidate.

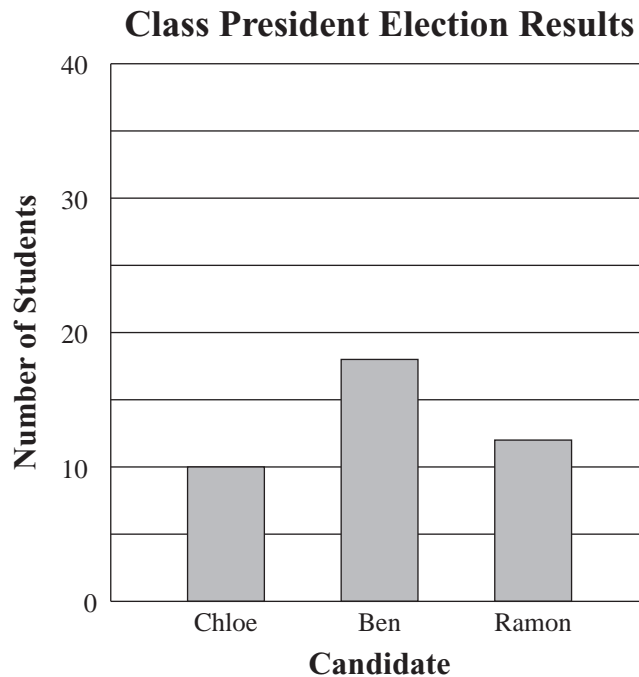

- a. Based on the graph, how many students voted for Ben? Explain your reasoning.
- b. Based on the graph, what is the total number of students who voted in the election? Show or explain how you got your answer.
- c. A reporter for the school newspaper wrote that each candidate got less than 50% of the total number of votes. Is the reporter correct? Explain your reasoning.

Questions 11 and 12 are short-answer questions. Write your answers to these questions in the boxes provided in your Student Answer Booklet. Do not write your answers in this test booklet. You may do your figuring in the test booklet.

- 11 Will earned the following grades on his last five mathematics tests.

88, 79, 99, 96, 91

What was Will's median grade for these five tests?

- 12 A triangular prism is shown below.

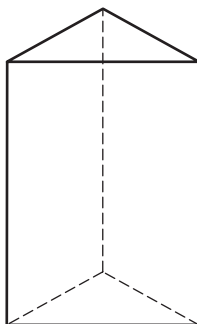

What is the total number of vertices in a triangular prism?

Question 13 is an open-response question.

- **BE SURE TO ANSWER AND LABEL ALL PARTS OF THE QUESTION.**
- **Show all your work (diagrams, tables, or computations) in your Student Answer Booklet.**
- **If you do the work in your head, explain in writing how you did the work.**

Write your answer to question 13 in the space provided in your Student Answer Booklet.

13 The Fish Bowl store had a sale. During the sale, the store gave away two kinds of fish, goldfish and catfish.

- Every 5th customer received a free goldfish.
- Every 12th customer received a free catfish.

There were 134 customers on the day of the sale.

- a. How many customers received a free goldfish? Show or explain how you got your answer.
- b. How many customers received a free catfish? Show or explain how you got your answer.
- c. How many customers received **both** a free goldfish and a free catfish? Show or explain how you got your answer.

Mark your answers to multiple-choice questions 14 through 16 in the spaces provided in your Student Answer Booklet. Do not write your answers in this test booklet. You may do your figuring in the test booklet.

- 14 Which of the following is equivalent to the expression below?

$$10^4$$

- A. 104
- B. $10 + 4$
- C. 10×4
- D. $10 \times 10 \times 10 \times 10$

- 15 Madison started a bicycle trip at 2:00 p.m. At 5:00 p.m. the same day she had completed 75% of the total distance.

If Madison continues at the same speed, at what time will she finish the total distance?

- A. 6:00 p.m.
- B. 6:30 p.m.
- C. 7:00 p.m.
- D. 7:30 p.m.

- 16 Jack has 18 toy cars. Each car weighs 4.2 ounces.

Which of the following expressions has a value that is closest to the total weight, in ounces, of Jack's 18 toy cars?

- A. 10×4
- B. 10×5
- C. 20×4
- D. 20×5

Question 17 is an open-response question.

- **BE SURE TO ANSWER AND LABEL ALL PARTS OF THE QUESTION.**
- **Show all your work (diagrams, tables, or computations) in your Student Answer Booklet.**
- **If you do the work in your head, explain in writing how you did the work.**

Write your answer to question 17 in the space provided in your Student Answer Booklet.

- 17 Georgia has some 4-inch cubes like the one shown below.

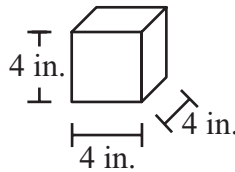

Georgia will put the cubes in the box shown below.

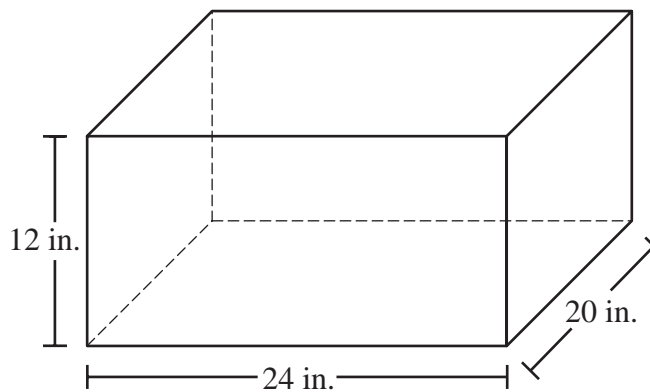

- What is the total number of cubes that Georgia needs to exactly cover the bottom of the box with a layer one cube deep? Show or explain how you got your answer.
- Georgia is going to fill the entire box with her cubes. What is the total number of cubes that Georgia needs? Show or explain how you got your answer.

Mathematics

SESSION 2

You may use your reference sheet and MCAS ruler during this session.
You may **not** use a calculator during this session.



DIRECTIONS

This session contains seventeen multiple-choice questions, three short-answer questions, and two open-response questions. Mark your answers to these questions in the spaces provided in your Student Answer Booklet.

- 18 Which of the following sentences best describes two parallel lines?

- A. They meet at exactly one point.
- B. They meet at exactly two points.
- C. They form a right angle.
- D. They are always the same distance apart.

- 19 What is the value of the expression below?

$$4 \times (9 - 6)$$

- A. 12
- B. 15
- C. 30
- D. 60

- 20 The graph below shows the relationship between gasoline used and total distance traveled for Katya's car.

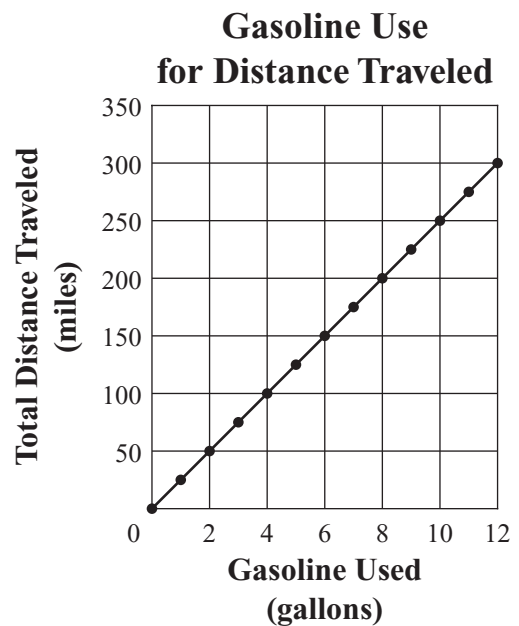

Based on this graph, what is the number of miles traveled per gallon of gasoline used?

- A. 25 miles per gallon
- B. 50 miles per gallon
- C. 75 miles per gallon
- D. 100 miles per gallon

- 21 Tenisha is planning a backpacking trip. The table below shows the weights of the items she has packed so far.

**Backpacking Trip
Items and Weights**

Item	Weight
tent	4 pounds 4 ounces
sleeping bag	2 pounds 10 ounces
food	5 pounds 6 ounces

What is the total weight of the items listed in the table? (1 pound = 16 ounces)

- A. 12 pounds
 - B. 12 pounds 4 ounces
 - C. 12 pounds 8 ounces
 - D. 13 pounds
- 22 Which of the following is equivalent to the expression below?

$$(6 \times 1) + (5 \times 0.01) + (8 \times 0.001)$$

- A. 65.08
- B. 60.58
- C. 6.508
- D. 6.058

- 23 A baker had 1128 cookies. She put them all in bags, with 24 cookies in each bag. What is the total number of bags that she used?

- A. 37
- B. 38
- C. 47
- D. 48

- 24 Paula uses the rule below to estimate the distance of a thunderstorm from her location.

Paula’s Rule

Count the number of seconds between seeing the lightning and hearing the thunder.
For every 5 seconds counted, the storm is 1 mile away.

Based on Paula’s rule, which of the following tables shows the relationship between the number of seconds counted and the distance of the thunderstorm?

A. **Thunderstorm Distance**

Time (in seconds)	Distance (in miles)
0	0
5	1
10	2
15	3
20	4

C. **Thunderstorm Distance**

Time (in seconds)	Distance (in miles)
1	0
2	5
3	10
4	15
5	20

B. **Thunderstorm Distance**

Time (in seconds)	Distance (in miles)
0	1
5	2
10	3
15	4
20	5

D. **Thunderstorm Distance**

Time (in seconds)	Distance (in miles)
0	0
1	5
2	10
3	15
4	20

- 25 Barbara wrote the equation shown below.

$$\square \div 6 = 3$$

If Barbara's equation is true, which of the following equations must also be true?

- A. $6 \div \square = 3$
- B. $3 \times \square = 6$
- C. $\square = 3 + 6$
- D. $3 \times 6 = \square$

- 26 Carol is training for a bicycle race. The number of miles that she rode her bicycle on each of the past 5 days is shown below.

12, 18, 13, 17, 20

What is the mean (average) number of miles that Carol rode her bicycle per day?

- A. 13 miles
- B. 16 miles
- C. 17 miles
- D. 20 miles

Question 27 is an open-response question.

- **BE SURE TO ANSWER AND LABEL ALL PARTS OF THE QUESTION.**
- **Show all your work (diagrams, tables, or computations) in your Student Answer Booklet.**
- **If you do the work in your head, explain in writing how you did the work.**

Write your answer to question 27 in the space provided in your Student Answer Booklet.

- 27 Zulma drew the triangle shown below.

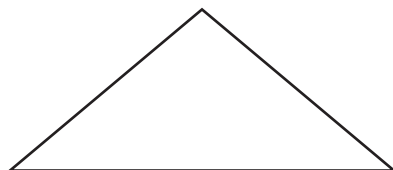

- a. What is the total number of lines of symmetry that the triangle appears to have? Show or explain how you got your answer.
- b. On the grid in your Student Answer Booklet, draw a quadrilateral that has **exactly two** lines of symmetry. Draw the lines of symmetry.
- c. On the grid in your Student Answer Booklet, draw a quadrilateral that has **more than two** lines of symmetry. Draw the lines of symmetry.

Questions 28 and 29 are short-answer questions. Write your answers to these questions in the boxes provided in your Student Answer Booklet. Do not write your answers in this test booklet. You may do your figuring in the test booklet.

- 28 Compute:

$$12.63 - 3.72$$

- 29 The circle below is divided into congruent parts. What **percent** of the whole circle is shaded?

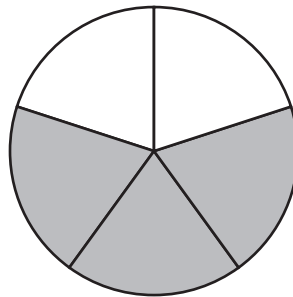

Question 30 is a short-answer question. Write your answer to this question in the box provided in your Student Answer Booklet. Do not write your answer in this test booklet. You may do your figuring in the test booklet.

- 30** The perimeter of an equilateral triangle is 24 centimeters. How many centimeters long is each side of the triangle?

Question 31 is an open-response question.

- **BE SURE TO ANSWER AND LABEL ALL PARTS OF THE QUESTION.**
- **Show all your work (diagrams, tables, or computations) in your Student Answer Booklet.**
- **If you do the work in your head, explain in writing how you did the work.**

Write your answer to question 31 in the space provided in your Student Answer Booklet.

- 31** Ms. Taylor is playing a number game with one of her students. When the student tells Ms. Taylor a number, Ms. Taylor uses a rule to determine a new number. Ms. Taylor always uses the same rule.

The table below shows some of the student's numbers and Ms. Taylor's numbers.

Number Game

Student's Number	Ms. Taylor's Number
5	16
8	25
1	4
4	13
2	7

- What should be Ms. Taylor's number when the student's number is 6?
- When the student tells Ms. Taylor a number, what is the rule that Ms. Taylor uses to determine her number?
- If the student's numbers are always whole numbers, could 43 be one of Ms. Taylor's numbers? Show or explain how you got your answer.

Mark your answers to multiple-choice questions 32 through 39 in the spaces provided in your Student Answer Booklet. Do not write your answers in this test booklet. You may do your figuring in the test booklet.

- 32 What is the value of the expression below when $n = 3$?

$$58 - (4 \times n)$$

- A. 15
- B. 46
- C. 51
- D. 162

- 33 The location of point Q is shown on the number line below.

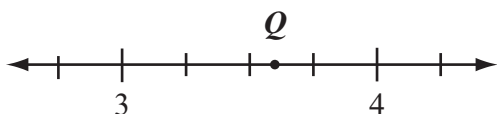

Which of the following numbers is best represented by point Q ?

- A. 3.4
- B. 3.6
- C. 3.8
- D. 4.4

- 34 Which of the following is a prime number?

- A. 65
- B. 58
- C. 39
- D. 23

- 35 Which of the following is equivalent to the expression below?

$$3\frac{3}{4} + 1\frac{1}{2}$$

- A. $4\frac{1}{4}$
- B. $4\frac{3}{4}$
- C. $5\frac{1}{4}$
- D. $5\frac{3}{4}$

- 36 The manager of an ice cream shop asked some boys and girls to vote for their favorite kind of sundae. The results are shown in the graph below.

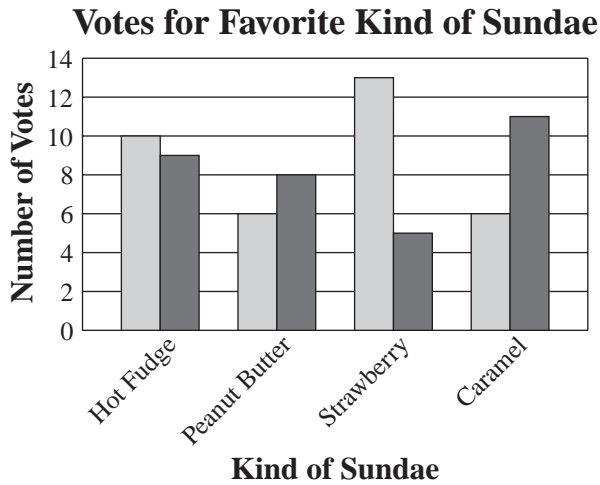

Key	
□	represents boys
■	represents girls

Which kind of sundae received the greatest **total** number of votes?

- A. hot fudge
- B. peanut butter
- C. strawberry
- D. caramel

- 37 There were 123 players at a soccer camp. The players were divided into teams having 11 players each. What was the total number of teams and the total number of players left over?

- A. 10 teams, with 3 players left over
- B. 11 teams, with 1 player left over
- C. 11 teams, with 2 players left over
- D. 12 teams, with 3 players left over

- 38 Molly will draw a figure on the grid shown below.

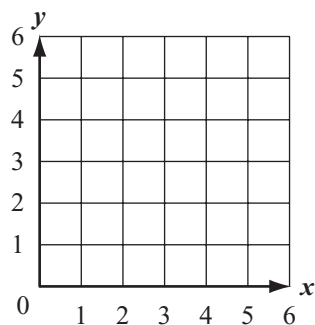

She will follow the steps below to draw the figure.

- Step 1: Draw a line segment from (1, 2) to (1, 4).
- Step 2: Draw a line segment from (1, 4) to (3, 2).
- Step 3: Draw a line segment from (3, 2) to (3, 4).

Which of the following figures will Molly draw?

- A. a square
- B. the letter N
- C. a triangle
- D. the letter H

- 39 For a sale, the price of a computer was reduced by \$100 to \$950. Which of the following expressions represents the price of the computer before the sale?

- A. $100 + 950$
- B. $100 - 950$
- C. $950 - 100$
- D. $950 \div 100$

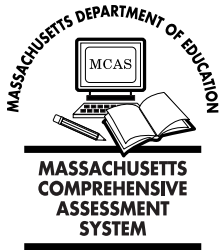

Massachusetts Comprehensive Assessment System Grade 5 Mathematics Reference Sheet

PERIMETER (P) FORMULAS

perimeter = distance around

square $P = 4 \times s$
(s = length of a side)

rectangle $P = (2 \times l) + (2 \times w)$
(l = length; w = width)

triangle $P = a + b + c$
(a , b , and c are the lengths of the sides)

VOLUME (V) FORMULAS

rectangular prism $V = l \times w \times h$
(l = length; w = width; h = height)

cube $V = s \times s \times s$
(s = length of an edge)

AREA (A) FORMULAS

square $A = s \times s$
(s = length of a side)

rectangle $A = l \times w$
(l = length; w = width)

triangle $A = \frac{1}{2} \times b \times h$
(b = length of the base;
 h = height)

Grade 5 Mathematics
Spring 2007 Released Items:
Reporting Categories, Standards, and Correct Answers

Item No.	Page No.	Reporting Category	Standard	Correct Answer (MC/SA)*
1	279	<i>Patterns, Relations, and Algebra</i>	5.P.1	B
2	279	<i>Number Sense and Operations</i>	5.N.2	B
3	280	<i>Geometry</i>	5.G.5	D
4	280	<i>Number Sense and Operations</i>	5.N.5	C
5	280	<i>Measurement</i>	5.M.5	A
6	281	<i>Patterns, Relations, and Algebra</i>	5.P.4	D
7	281	<i>Data Analysis, Statistics, and Probability</i>	5.D.3	C
8	282	<i>Number Sense and Operations</i>	5.N.7	A
9	282	<i>Patterns, Relations, and Algebra</i>	5.P.5	B
10	283	<i>Data Analysis, Statistics, and Probability</i>	5.D.2	
11	284	<i>Data Analysis, Statistics, and Probability</i>	5.D.1	91
12	284	<i>Geometry</i>	5.G.2	6
13	285	<i>Number Sense and Operations</i>	5.N.8	
14	286	<i>Number Sense and Operations</i>	5.N.1	D
15	286	<i>Patterns, Relations, and Algebra</i>	5.P.5	A
16	286	<i>Number Sense and Operations</i>	5.N.14	C
17	287	<i>Measurement</i>	5.M.4	
18	288	<i>Geometry</i>	5.G.3	D
19	288	<i>Number Sense and Operations</i>	5.N.10	A
20	288	<i>Patterns, Relations, and Algebra</i>	5.P.6	A
21	289	<i>Measurement</i>	5.M.3	B
22	289	<i>Number Sense and Operations</i>	5.N.3	D
23	289	<i>Number Sense and Operations</i>	5.N.12	C
24	290	<i>Patterns, Relations, and Algebra</i>	5.P.4	A
25	291	<i>Patterns, Relations, and Algebra</i>	5.P.3	D
26	291	<i>Data Analysis, Statistics, and Probability</i>	5.D.1	B
27	292	<i>Geometry</i>	5.G.6	
28	293	<i>Number Sense and Operations</i>	5.N.12	8.91
29	293	<i>Number Sense and Operations</i>	5.N.5	60%
30	294	<i>Measurement</i>	5.M.1	8 cm
31	295	<i>Patterns, Relations, and Algebra</i>	5.P.4	
32	296	<i>Patterns, Relations, and Algebra</i>	5.P.2	B
33	296	<i>Number Sense and Operations</i>	5.N.6	B
34	296	<i>Number Sense and Operations</i>	5.N.8	D
35	296	<i>Number Sense and Operations</i>	5.N.13	C
36	297	<i>Data Analysis, Statistics, and Probability</i>	5.D.2	A
37	297	<i>Number Sense and Operations</i>	5.N.9	C
38	298	<i>Geometry</i>	5.G.4	B
39	298	<i>Number Sense and Operations</i>	5.N.11	A

* Answers are provided here for multiple-choice items and short-answer items only. Sample responses and scoring guidelines for open-response items, which are indicated by shaded cells, will be posted to the Department's Web site later this year.

XII. Mathematics, Grade 6

Grade 6 Mathematics Test

The spring 2007 grade 6 MCAS Mathematics test was based on learning standards in the Massachusetts *Mathematics Curriculum Framework* (2000). The *Framework* identifies five major content strands, listed below. Page numbers for the grades 5–6 learning standards appear in parentheses.

- Number Sense and Operations (*Framework*, pages 25–26)
- Patterns, Relations, and Algebra (*Framework*, page 34)
- Geometry (*Framework*, page 42)
- Measurement (*Framework*, page 50)
- Data Analysis, Statistics, and Probability (*Framework*, page 58)

The *Mathematics Curriculum Framework* is available on the Department Web site at www.doe.mass.edu/frameworks/current.html.

In *Test Item Analysis Reports* and on the Subject Area Subscore pages of the *MCAS School Reports* and *District Reports*, Mathematics test results are reported under five MCAS reporting categories, which are identical to the five *Mathematics Curriculum Framework* content strands listed above.

Test Sessions

The MCAS grade 6 Mathematics test included two separate test sessions. Each session included multiple-choice, short-answer, and open-response questions.

Reference Materials and Tools

Each student taking the grade 6 Mathematics test was provided with a plastic ruler and a grade 6 Mathematics Reference Sheet. A copy of the reference sheet follows the final question in this chapter. An image of the ruler is not reproduced in this publication.

The use of bilingual word-to-word dictionaries was allowed for current and former limited English proficient students only, during both Mathematics test sessions. No calculators, other reference tools, or materials were allowed.

Cross-Reference Information

The table at the conclusion of this chapter indicates each item's reporting category and the *Framework* learning standard it assesses. The correct answers for multiple-choice and short-answer questions are also displayed in the table.

Mathematics

SESSION 1

You may use your reference sheet and MCAS ruler during this session.
You may **not** use a calculator during this session.



DIRECTIONS

This session contains twelve multiple-choice questions, two short-answer questions, and three open-response questions. Mark your answers to these questions in the spaces provided in your Student Answer Booklet.

- 1 Which of the following is equivalent to the expression below?

$$5^4$$

- A. 54
- B. 5×4
- C. $5 \times 5 \times 5 \times 5$
- D. $4 \times 4 \times 4 \times 4 \times 4$

- 2 Michael has exactly 204 stamps. He has 43 more stamps than Brian. What is the total number of stamps Brian has?

- A. 161
- B. 167
- C. 247
- D. 261

- 3 Nathan folded and taped a piece of cardboard to form the figure shown below.



Which of the following nets shows the unfolded figure?

A.

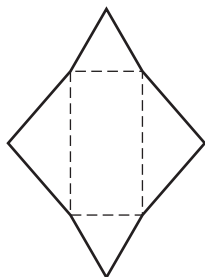

B.

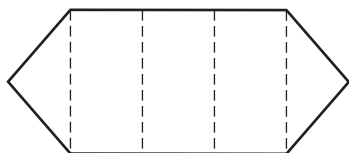

C.

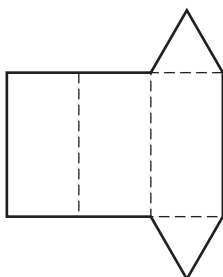

D.

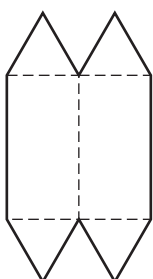

- 4 The table below shows the number of points that each player on a basketball team scored in his last game.

Points Scored

Player	Number of Points Scored
Alex	9
Doug	12
Nick	15
Keith	5
Sam	4

What percent of the total number of points did Alex score?

- A. 9%
 - B. 20%
 - C. 25%
 - D. 45%
- 5 What is the value of the expression below when $\square = 3$?

$$2(\square) + 5$$

- A. 6
- B. 7
- C. 10
- D. 11

- 6 A drawing of a pentagon is shown below.

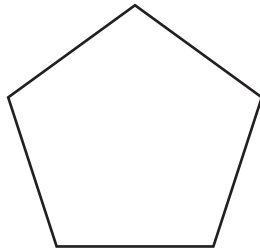

What is the sum of the measures of the interior angles of the pentagon?

- A. 180°
 - B. 360°
 - C. 540°
 - D. 720°
- 7 Last year, Jenna’s town recycled 9.85 tons of paper. This year, her town recycled 18.5 tons of paper.
- How much more paper did the town recycle this year than last year?
- A. 8.00 tons
 - B. 8.65 tons
 - C. 8.75 tons
 - D. 9.35 tons

- 8 Which of the following has the **greatest** value?

- A. $(2 \times 100,000) + (6 \times 100)$
- B. $(2 \times 100,000) + (5 \times 1,000)$
- C. $(3 \times 10,000) + (6 \times 100) + (7 \times 10)$
- D. $(3 \times 10,000) + (5 \times 1,000) + (7 \times 10)$

- 9 Each of the cards below is the same shape and size. The front of each card has a letter on it, and the back of each card is blank. Jack will put them all in a bag and then, without looking, take out one card.



What is the probability that Jack will take out a card with the letter T on it?

- A. $\frac{1}{8}$
- B. $\frac{1}{7}$
- C. $\frac{1}{4}$
- D. $\frac{1}{3}$

Question 10 is an open-response question.

- **BE SURE TO ANSWER AND LABEL ALL PARTS OF THE QUESTION.**
- **Show all your work (diagrams, tables, or computations) in your Student Answer Booklet.**
- **If you do the work in your head, explain in writing how you did the work.**

Write your answer to question 10 in the space provided in your Student Answer Booklet.

- 10 Lucinda earns \$20 each week. She spends \$5 each week and saves the rest. The table below shows the total amount that she saved at the end of each week for 4 weeks.

Lucinda's Savings at the End of Each Week

Week	1	2	3	4
Total Amount Saved	\$15	\$30	\$45	\$60

Lucinda continues to save at the same rate.

- What will be Lucinda's total amount saved at the end of 7 weeks? Show or explain how you got your answer.
- Use numbers, words, or symbols to write an expression that represents Lucinda's total amount saved at the end of n weeks.
- How many weeks will it take for Lucinda to save \$300? Show or explain how you got your answer.

Questions 11 and 12 are short-answer questions. Write your answers to these questions in the boxes provided in your Student Answer Booklet. Do not write your answers in this test booklet. You may do your figuring in the test booklet.

- 11 Write 84 as a product of prime numbers.

- 12 Using the number line below, what is the distance between point A and point B ?



Question 13 is an open-response question.

- **BE SURE TO ANSWER AND LABEL ALL PARTS OF THE QUESTION.**
- **Show all your work (diagrams, tables, or computations) in your Student Answer Booklet.**
- **If you do the work in your head, explain in writing how you did the work.**

Write your answer to question 13 in the space provided in your Student Answer Booklet.

13 Six geometric terms are given in the box below.

acute	equilateral	isosceles
obtuse	right	scalene

David drew the six triangles shown below.

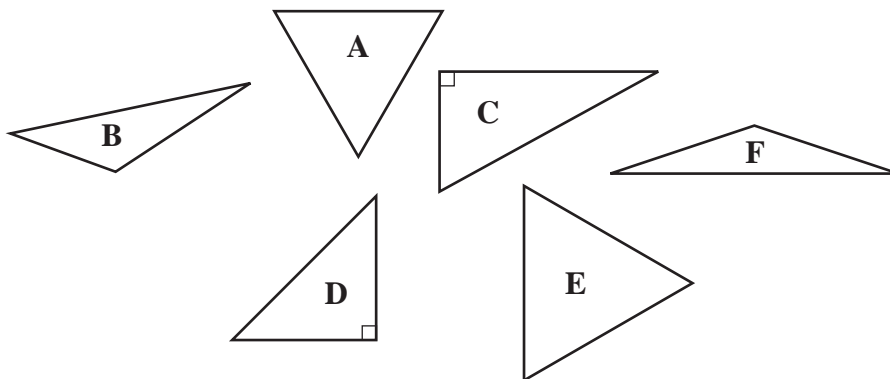

- Identify one of the geometric terms listed in the box that can be used to describe triangle A. Explain your reasoning.
- Which **two** of the geometric terms listed in the box can be used to describe triangle B? Explain your reasoning.

David grouped his triangles as shown below.

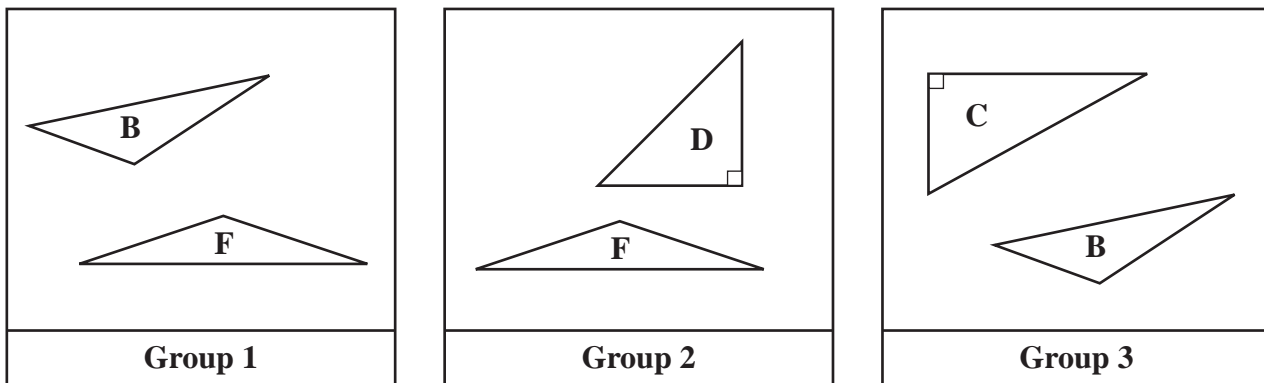

- Using one or more of the geometric terms listed in the box, explain what the two triangles in each group have in common. Be sure to label your answers Group 1, Group 2, and Group 3.

Mark your answers to multiple-choice questions 14 through 16 in the spaces provided in your Student Answer Booklet. Do not write your answers in this test booklet. You may do your figuring in the test booklet.

- 14 Francisco, Leon, and Jack each had the same number of trading cards.
- Francisco put his cards into groups of 3 with none left over.
 - Leon put his cards into groups of 4 with none left over.
 - Jack put his cards into groups of 9 with none left over.

Which of the following could be the total number of trading cards each person had?

- A. 72
- B. 81
- C. 84
- D. 90

- 15 Ted used the amounts of spices listed below to make a pie.

- 2 teaspoons of cinnamon
- $\frac{3}{4}$ teaspoon of nutmeg
- $\frac{1}{2}$ teaspoon of cloves

What is the total number of teaspoons of spices that Ted used?

- A. $2\frac{3}{8}$ teaspoons
- B. $2\frac{4}{6}$ teaspoons
- C. $3\frac{1}{4}$ teaspoons
- D. $3\frac{1}{2}$ teaspoons

- 16 In which of the following tables do the data show a constant rate of change in the total distance traveled during a four-hour trip?

A. **Distance Traveled**

Time (hours)	Total Distance (miles)
1	50
2	80
3	140
4	230

C. **Distance Traveled**

Time (hours)	Total Distance (miles)
1	60
2	120
3	150
4	165

B. **Distance Traveled**

Time (hours)	Total Distance (miles)
1	30
2	60
3	120
4	240

D. **Distance Traveled**

Time (hours)	Total Distance (miles)
1	50
2	100
3	150
4	200

Question 17 is an open-response question.

- **BE SURE TO ANSWER AND LABEL ALL PARTS OF THE QUESTION.**
- **Show all your work (diagrams, tables, or computations) in your Student Answer Booklet.**
- **If you do the work in your head, explain in writing how you did the work.**

Write your answer to question 17 in the space provided in your Student Answer Booklet.

- 17 Emily works at a fitness center. She recorded the heart rates of some people immediately after they exercised. Her data are shown below.

Heart Rates (beats per minute)

120	128	144	136	130
150	138	140	132	130

- Construct a stem-and-leaf plot to show Emily's data. Be sure to include a key.
- Based on Emily's data, what is the **median** heart rate? Show or explain how you got your answer.

Emily measured the heart rates of two more people. When these heart rates were added to the data set, the **mode** decreased.

- Explain what must be true of the two additional heart rates in order for the **mode** to decrease.
- Explain how the two additional heart rates will affect the **median** heart rate that you found in part (b).

Mathematics

SESSION 2

You may use your reference sheet and MCAS ruler during this session.
You may **not** use a calculator during this session.



DIRECTIONS

This session contains seventeen multiple-choice questions, three short-answer questions, and two open-response questions. Mark your answers to these questions in the spaces provided in your Student Answer Booklet.

- 18 The measure of an angle is 100° . What kind of angle is this?

A. right
B. acute
C. obtuse
D. straight

- 19 Megan bought a box of 30 cookies. She ate $\frac{1}{3}$ of them. What is the total number of cookies that Megan ate?

A. 27
B. 10
C. 9
D. 3

- 20 The graph below shows the relationship between distance measured in kilometers and distance measured in miles.

Measures of Distance

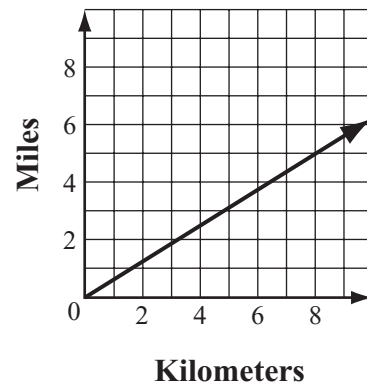

Which of the following is closest to the number of miles that is equivalent to 4 kilometers?

- A. 1.5 miles
B. 2.5 miles
C. 5.8 miles
D. 6.2 miles

- 21 What is the value of n that makes the equation below true?

$$\frac{n}{3} = 12$$

- A. 4
- B. 9
- C. 15
- D. 36

- 22 At one time, the world population was 6,034,627,105. What digit is in the millions place of 6,034,627,105?

- A. 0
- B. 3
- C. 4
- D. 6

- 23 Jon and his friends painted a mural in art class. The shaded part of the figure below represents the part of the mural that Jon painted.



Which of the following best represents the percent of the mural that Jon painted?

- A. 20%
- B. 25%
- C. 33%
- D. 40%

- 24 The cost for labor at a car repair center is shown in the table below.

Car Repair Costs

Hours	Total Cost
1	\$ 60
2	\$120
3	\$180
4	\$240

Based on the data in the table, which of the following expressions represents the total cost, in dollars, of a repair that requires h hours of labor?

- A. $h + 60$
- B. $h - 60$
- C. $h \times 60$
- D. $h \div 60$

- 25 The line plot below shows the number of books individual customers bought at a bookstore one day.

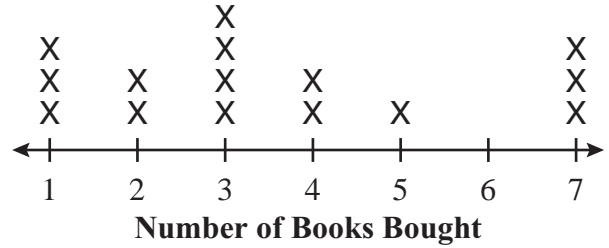

What was the total number of customers who bought **more than** 3 books?

- A. 4
- B. 6
- C. 7
- D. 10

- 26 The table below shows the lowest recorded temperature for each of four cities.

Lowest Recorded Temperatures

City	Temperature (in degrees Fahrenheit)
Detroit, Michigan	-21
San Juan, Puerto Rico	60
Fairbanks, Alaska	-62
Seattle, Washington	9

Which of the following shows these numbers in order from least to greatest?

- A. -62, -21, 9, 60
- B. 9, -21, 60, -62
- C. -62, 60, -21, 9
- D. -21, -62, 9, 60

Question 27 is an open-response question.

- **BE SURE TO ANSWER AND LABEL ALL PARTS OF THE QUESTION.**
- **Show all your work (diagrams, tables, or computations) in your Student Answer Booklet.**
- **If you do the work in your head, explain in writing how you did the work.**

Write your answer to question 27 in the space provided in your Student Answer Booklet.

Use your MCAS ruler to answer question 27.

- 27** Part of a map is shown below. Each point is labeled to indicate the town that it represents. The map has a scale in which 1 inch represents 20 miles.

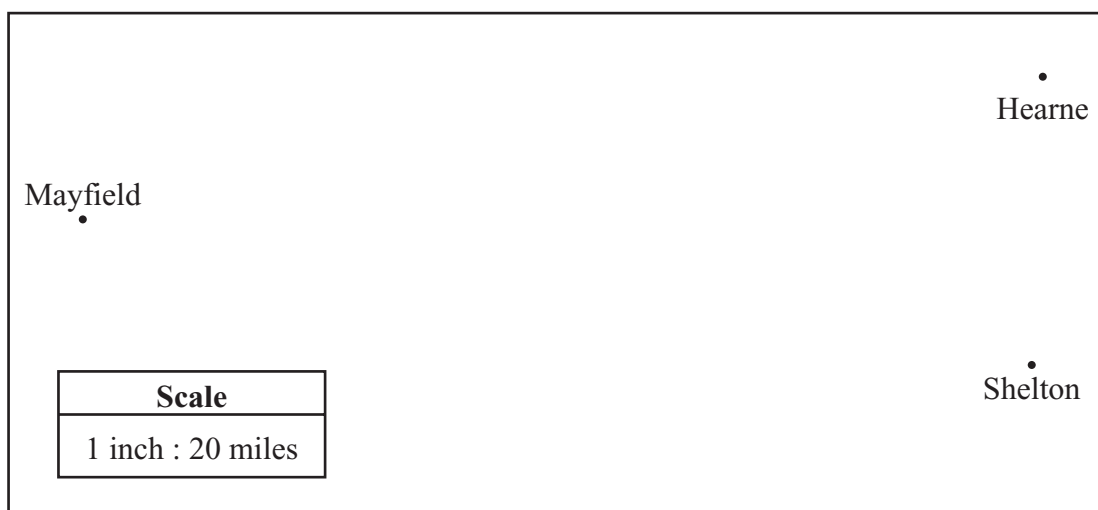

- a. Using your MCAS ruler, what is the distance, in inches, between Mayfield and Shelton on the map?
- b. What is the actual distance, in miles, between the towns of Mayfield and Shelton? Show or explain how you used the scale to get your answer.
- c. What is the actual distance, in miles, between the towns of Hearne and Shelton? Show or explain how you used the scale to get your answer.
- d. The town of Sawyer is located 50 miles from Mayfield. On the full map, what should be the distance, in inches, between Sawyer and Mayfield? Show or explain how you got your answer.

Questions 28 and 29 are short-answer questions. Write your answers to these questions in the boxes provided in your Student Answer Booklet. Do not write your answers in this test booklet. You may do your figuring in the test booklet.

- 28 What number best represents the location of point A on the number line below?

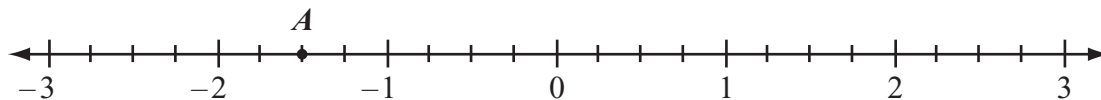

- 29 A hexagonal prism is shown below.

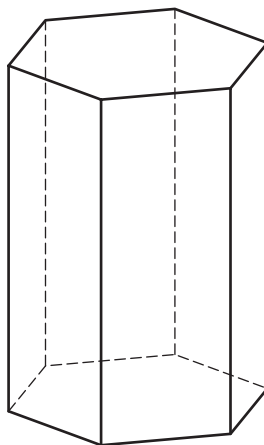

What is the total number of edges in a hexagonal prism?

Question 30 is a short-answer question. Write your answer to this question in the box provided in your Student Answer Booklet. Do not write your answer in this test booklet. You may do your figuring in the test booklet.

- 30 The shaded figure below represents Peggy’s garden.

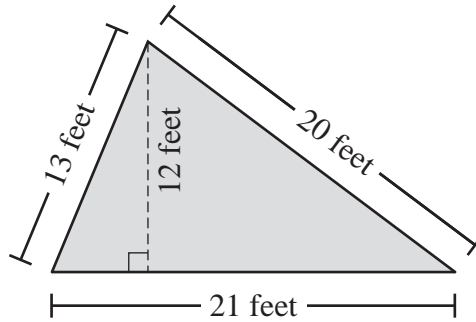

Based on the dimensions in the figure, what is the perimeter, in feet, of Peggy’s garden?

Question 31 is an open-response question.

- **BE SURE TO ANSWER AND LABEL ALL PARTS OF THE QUESTION.**
- **Show all your work (diagrams, tables, or computations) in your Student Answer Booklet.**
- **If you do the work in your head, explain in writing how you did the work.**

Write your answer to question 31 in the space provided in your Student Answer Booklet.

- 31** Carla made the table below to show the populations of five different states.

State Populations

State	Population (in millions)
Massachusetts	6.35
New Hampshire	1.24
New York	18.98
Pennsylvania	12.28
Vermont	0.61

- Based on the data in the table, write the states in order from the **greatest** population to the **least** population.
- Based on the data in the table, estimate how many more people live in Pennsylvania than in Vermont. Show or explain your strategy.
- Based on the data in the table, estimate the total number of people who live in all five states. Show or explain your strategy.
- Based on your answer to part (c), estimate the percent of the total population of the five states that is from Massachusetts. Show or explain how you got your answer.

Mark your answers to multiple-choice questions 32 through 39 in the spaces provided in your Student Answer Booklet. Do not write your answers in this test booklet. You may do your figuring in the test booklet.

- 32 Each night, Stephanie reads 3 more pages of her book than Michael reads of his book. Which of the following graphs correctly represents the relationship between the number of pages Stephanie reads each night and the number of pages Michael reads each night?

A. **Pages Read Each Night**

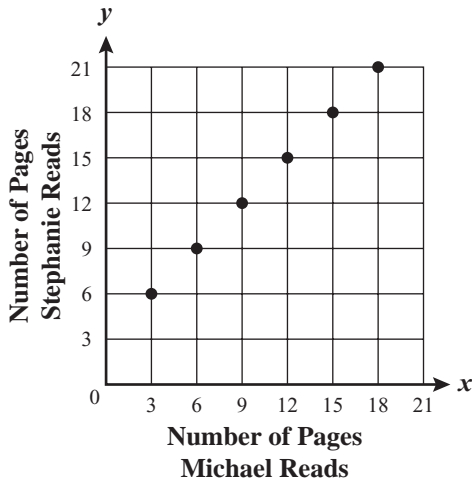

C. **Pages Read Each Night**

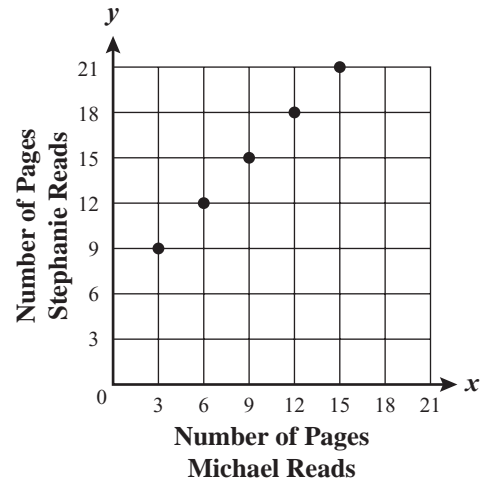

B. **Pages Read Each Night**

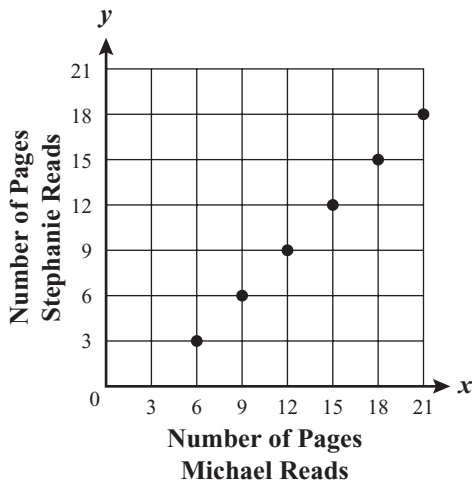

D. **Pages Read Each Night**

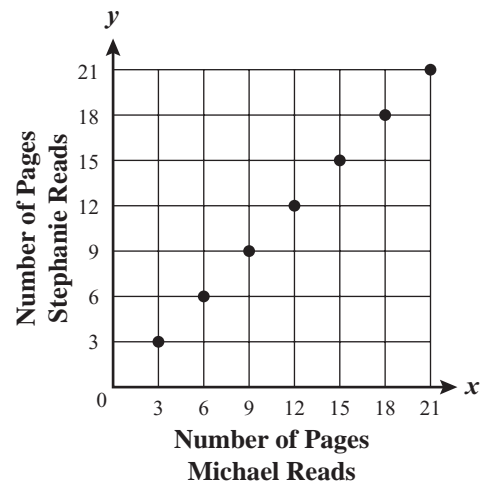

- 33 What is the value of the expression shown below?

$$3 + (2 + 5) \times 3$$

- A. 13
- B. 20
- C. 24
- D. 30

- 34 A comet passed by Earth in the year 1835. It passes by Earth every 60 years. Based on this information, in which of the following years can the comet be expected to pass by Earth?

- A. 2035
- B. 2060
- C. 2075
- D. 2080

- 35 Which of the following figures appears to have both line symmetry and rotational symmetry?

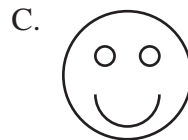
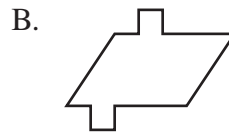
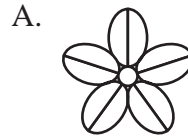

- 36 Which of the following could be the rule used to create the number pattern shown below?

250, 130, 70, 40, 25

- A. Subtract 120.
- B. Subtract 10; then divide the result by 2.
- C. Divide by 2.
- D. Divide by 2; then add 5 to the result.

- 37 Which of the following numbers best represents the location of point P on the number line below?

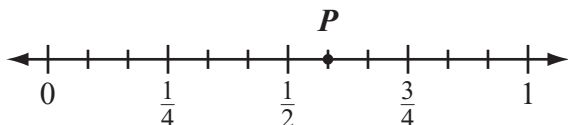

- A. $\frac{1}{3}$
- B. $\frac{2}{3}$
- C. $\frac{7}{9}$
- D. $\frac{7}{12}$

- 38 Karen purchased a new camera for \$60. She also purchased 5 rolls of film. The total cost of the camera and the rolls of film was \$90. Karen's purchase is represented by the equation below. In the equation, f stands for the cost of each roll of film.

$$5f + 60 = 90$$

What was the cost of each roll of film that Karen purchased?

- A. \$6
- B. \$12
- C. \$18
- D. \$30

- 39 Alex practiced playing the piano each day last week. The number of minutes he practiced each day is shown in the table below.

Piano Practice Time per Day

Day	Time (minutes)
Sunday	55
Monday	20
Tuesday	25
Wednesday	45
Thursday	50
Friday	20
Saturday	30

What is the median number of minutes per day that Alex practiced last week?

- A. 20 minutes
- B. 30 minutes
- C. 35 minutes
- D. 45 minutes

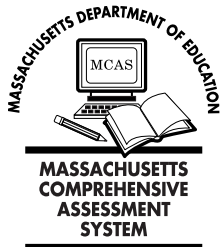

Massachusetts Comprehensive Assessment System Grade 6 Mathematics Reference Sheet

PERIMETER FORMULAS

perimeter = distance around

square $P = 4s$

rectangle $P = 2b + 2h$

OR

$P = 2l + 2w$

triangle $P = a + b + c$

AREA FORMULAS

square $A = s \times s$

rectangle $A = bh$

OR

$A = lw$

parallelogram $A = bh$

triangle $A = \frac{1}{2}bh$

circle $A = \pi r^2$

VOLUME FORMULAS

rectangular prism $V = lwh$

cube $V = s \times s \times s$

(s = length of an edge)

CIRCLE FORMULAS

$C = 2\pi r$

OR

$C = \pi d$

$A = \pi r^2$

Grade 6 Mathematics
Spring 2007 Released Items:
Reporting Categories, Standards, and Correct Answers

Item No.	Page No.	Reporting Category	Standard	Correct Answer (MC/SA)*
1	303	<i>Number Sense and Operations</i>	6.N.1	C
2	303	<i>Number Sense and Operations</i>	6.N.12	A
3	304	<i>Geometry</i>	6.G.9	C
4	304	<i>Number Sense and Operations</i>	6.N.9	B
5	304	<i>Patterns, Relations, and Algebra</i>	6.P.2	D
6	305	<i>Measurement</i>	6.M.7	C
7	305	<i>Number Sense and Operations</i>	6.N.13	B
8	305	<i>Number Sense and Operations</i>	6.N.3	B
9	305	<i>Data Analysis, Statistics, and Probability</i>	6.D.4	C
10	306	<i>Patterns, Relations, and Algebra</i>	6.P.4	
11	307	<i>Number Sense and Operations</i>	6.N.8	$2 \times 2 \times 3 \times 7$
12	307	<i>Geometry</i>	6.G.5	$2\frac{2}{3}$ or equivalent
13	308	<i>Geometry</i>	6.G.1	
14	309	<i>Number Sense and Operations</i>	6.N.8	A
15	309	<i>Number Sense and Operations</i>	6.N.14	C
16	310	<i>Patterns, Relations, and Algebra</i>	6.P.7	D
17	311	<i>Data Analysis, Statistics, and Probability</i>	6.D.1	
18	312	<i>Measurement</i>	6.M.2	C
19	312	<i>Number Sense and Operations</i>	6.N.4	B
20	312	<i>Patterns, Relations, and Algebra</i>	6.P.6	B
21	313	<i>Patterns, Relations, and Algebra</i>	6.P.3	D
22	313	<i>Number Sense and Operations</i>	6.N.2	C
23	313	<i>Number Sense and Operations</i>	6.N.5	D
24	314	<i>Patterns, Relations, and Algebra</i>	6.P.4	C
25	314	<i>Data Analysis, Statistics, and Probability</i>	6.D.2	B
26	315	<i>Number Sense and Operations</i>	6.N.7	A
27	316	<i>Measurement</i>	6.M.3	
28	317	<i>Number Sense and Operations</i>	6.N.6	$-1\frac{1}{2}$ or equivalent
29	317	<i>Geometry</i>	6.G.2	18
30	318	<i>Measurement</i>	6.M.1	54 feet
31	319	<i>Number Sense and Operations</i>	6.N.16	
32	320	<i>Patterns, Relations, and Algebra</i>	6.P.6	A
33	321	<i>Number Sense and Operations</i>	6.N.11	C
34	321	<i>Patterns, Relations, and Algebra</i>	6.P.1	C
35	321	<i>Geometry</i>	6.G.7	A
36	321	<i>Patterns, Relations, and Algebra</i>	6.P.1	D
37	322	<i>Number Sense and Operations</i>	6.N.6	D
38	322	<i>Patterns, Relations, and Algebra</i>	6.P.5	A
39	323	<i>Data Analysis, Statistics, and Probability</i>	6.D.1	B

* Answers are provided here for multiple-choice items and short-answer items only. Sample responses and scoring guidelines for open-response items, which are indicated by shaded cells, will be posted to the Department's Web site later this year.

XIII. Mathematics, Grade 7

Grade 7 Mathematics Test

The spring 2007 grade 7 MCAS Mathematics test was based on learning standards in the Massachusetts *Mathematics Curriculum Framework* (2000). The *Framework* identifies five major content strands, listed below. Specific learning standards for grade 7 are found in the *Supplement to the Massachusetts Mathematics Curriculum Framework* (2004). Page numbers for the grades 7–8 *Framework* learning standards and for the grade 7 *Supplement* standards appear in parentheses.

- Number Sense and Operations (*Framework*, page 62; *Supplement*, page 11)
- Patterns, Relations, and Algebra (*Framework*, page 63; *Supplement*, page 12)
- Geometry (*Framework*, page 64; *Supplement*, pages 12–13)
- Measurement (*Framework*, page 65; *Supplement*, page 13)
- Data Analysis, Statistics, and Probability (*Framework*, page 66; *Supplement*, page 14)

The *Mathematics Curriculum Framework* and *Supplement* are available on the Department Web site at www.doe.mass.edu/frameworks/current.html.

In *Test Item Analysis Reports* and on the Subject Area Subscore pages of the MCAS *School Reports* and *District Reports*, Mathematics test results are reported under five MCAS reporting categories, which are identical to the five *Framework* content strands listed above.

Test Sessions

The MCAS grade 7 Mathematics test included two separate test sessions. Each session included multiple-choice and open-response questions. Session 1 also included short-answer questions.

Reference Materials and Tools

Each student taking the grade 7 Mathematics test was provided with a plastic ruler and a grade 7 Mathematics Reference Sheet. A copy of the reference sheet follows the final question in this chapter. An image of the ruler is not reproduced in this publication.

During session 2, each student had sole access to a calculator with at least four functions and a square root key. Calculator use was not allowed during session 1.

The use of bilingual word-to-word dictionaries was allowed for current and former limited English proficient students only, during both Mathematics test sessions. No other reference tools or materials were allowed.

Cross-Reference Information

The table at the conclusion of this chapter indicates each item's reporting category and the *Framework* learning standard it assesses. The correct answers for multiple-choice and short-answer questions are also displayed in the table.

Mathematics

SESSION 1

You may use your reference sheet and MCAS ruler during this session.
You may **not** use a calculator during this session.



DIRECTIONS

This session contains fifteen multiple-choice questions, five short-answer questions, and two open-response questions. Mark your answers to these questions in the spaces provided in your Student Answer Booklet.

- 1 The depth of the water in a tank was 5 feet. At noon, Haley started draining water out of the tank at a steady rate, as shown by the graph below.

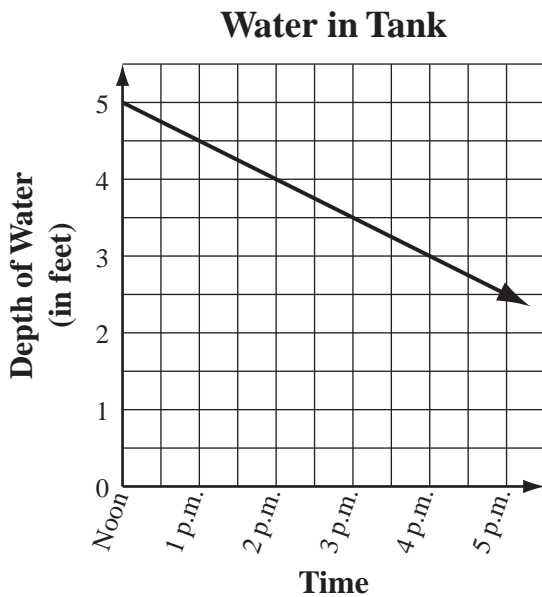

Based on the rate shown by the graph, at what time will the depth of the water in the tank be 2 feet?

- A. 2 p.m.
- B. 4 p.m.
- C. 6 p.m.
- D. 8 p.m.

- 2 What is the value of the expression below?

$$(2 + 5)^2$$

- A. 14
- B. 27
- C. 29
- D. 49

- 3 The tail of a comet can be up to 45,100,000 kilometers long. What is 45,100,000 written in scientific notation?

- A. 4.51×10^8
- B. 4.51×10^7
- C. 4.51×10^6
- D. 4.51×10^5

- 4 Angelie shaded a figure on a coordinate plane, as shown below.

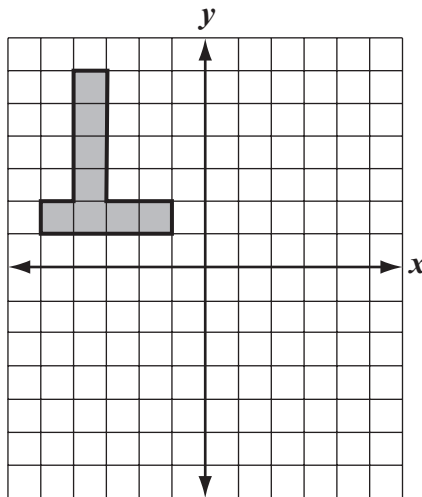

Which of the following best represents the reflection of Angelie's figure across the y-axis?

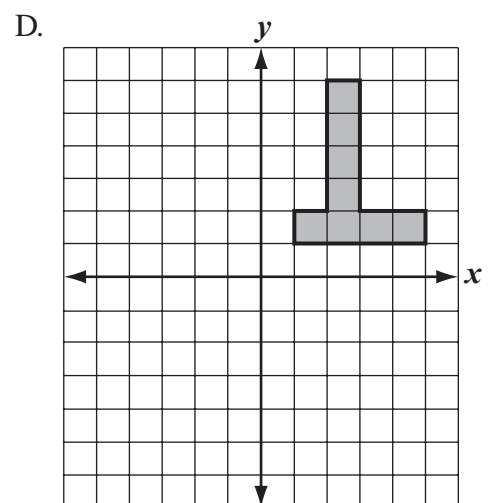
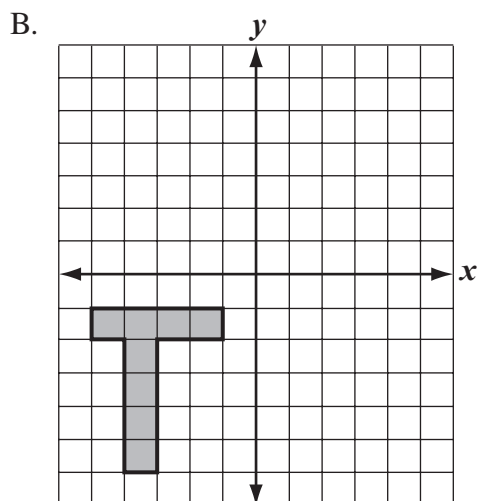
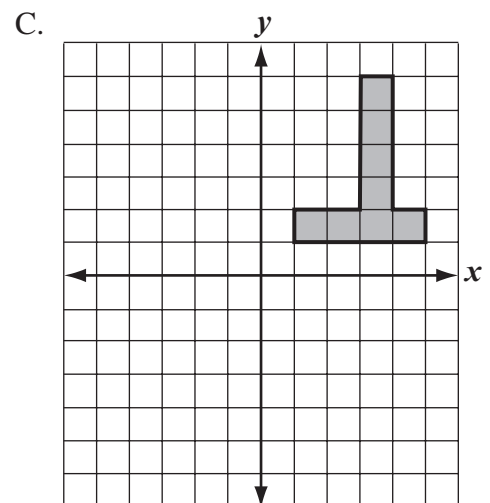
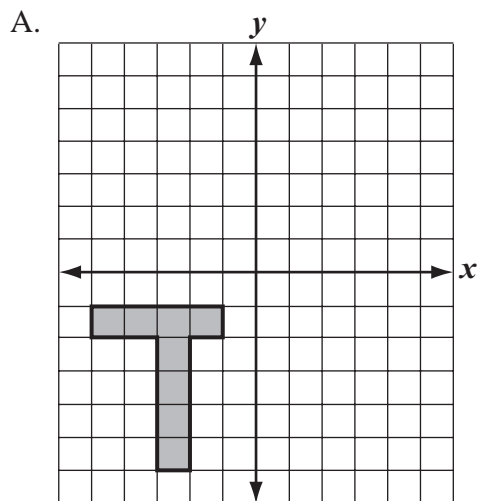

- 5 Horseshoe Falls has an average water flow of 600,000 gallons per second. What is the average water flow of Horseshoe Falls in gallons per **minute**?
- A. 10,000 gallons per minute
 - B. 100,000 gallons per minute
 - C. 3,600,000 gallons per minute
 - D. 36,000,000 gallons per minute
- 6 Which of the following has the greatest value?
- A. $|10|$
 - B. $|12|$
 - C. $|-14|$
 - D. $|-8|$

Questions 7 and 8 are short-answer questions. Write your answers to these questions in the boxes provided in your Student Answer Booklet. Do not write your answers in this test booklet. You may do your figuring in the test booklet.

- 7 The figure below is a quadrilateral.

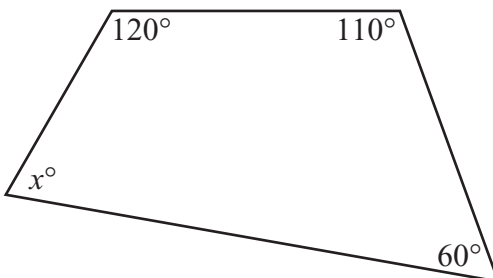

What is the value of x in the quadrilateral?

- 8 The table below shows the relationship between t , the number of tickets to a school social, and c , the total cost, in dollars, of the tickets.

Total Cost of Tickets

Number of Tickets (t)	Total Cost in Dollars (c)
1	5
2	10
3	15
4	20

Write an equation that represents the relationship between t and c for the data shown in the table.

Question 9 is an open-response question.

- **BE SURE TO ANSWER AND LABEL ALL PARTS OF THE QUESTION.**
- **Show all your work (diagrams, tables, or computations) in your Student Answer Booklet.**
- **If you do the work in your head, explain in writing how you did the work.**

Write your answer to question 9 in the space provided in your Student Answer Booklet.

9 Sandy purchased three trees.

- The price of the first tree was \$63.50.
 - The price of the second tree was equal to twice the price of the **first** tree.
 - The price of the third tree was equal to $\frac{3}{4}$ of the price of the **second** tree.
- a. What was the price of the second tree? Show or explain how you got your answer.
 - b. What was the price of the third tree? Show or explain how you got your answer.
 - c. What was the total of the prices of all three trees? Show or explain how you got your answer.
 - d. Sandy had to pay sales tax of 5% on her purchase. What was the total amount of Sandy's purchase of three trees, including tax? Show or explain how you got your answer.

Mark your answers to multiple-choice questions 10 through 18 in the spaces provided in your Student Answer Booklet. Do not write your answers in this test booklet. You may do your figuring in the test booklet.

10 Carly made 21 out of 83 shots while practicing basketball. Which of the following is closest to the percentage of shots that Carly made?

- A. 20%
- B. 25%
- C. 30%
- D. 40%

11 Heather asked her classmates if they went to a movie, a play, a concert, or any combination of those events during the last month. The Venn diagram below represents her data.

Students Attending Events

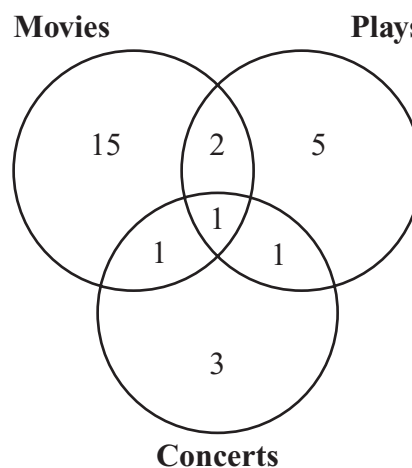

Based on the diagram, what is the total number of Heather’s classmates who went to a concert during the last month?

- A. 3
- B. 4
- C. 5
- D. 6

- 12 Sally found the following information about Massachusetts.
- The land area of Massachusetts is 7,804 square miles.
 - The population of Massachusetts was 6,379,304 in 2001.

Population density is determined using the formula below.

$\text{population density} = \text{population} \div \text{land area}$

Based on the information that Sally found, which of the following estimates is closest to the population density of Massachusetts in 2001?

- A. 1,000 people per square mile
- B. 800 people per square mile
- C. 640 people per square mile
- D. 600 people per square mile

- 13 Steven has one bag that contains three table-tennis balls numbered 1, 2, and 3. He also has a second bag that contains four table-tennis balls lettered A, B, C, and D.

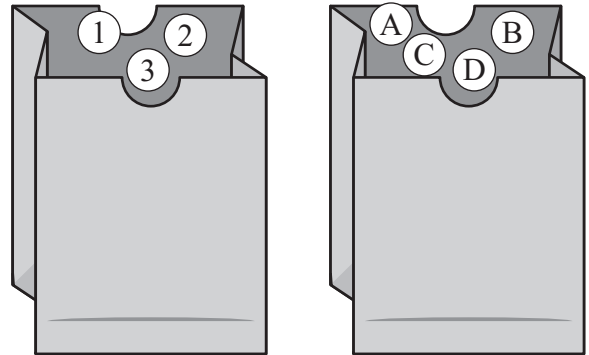

The organized list in the box below shows all of the possible combinations of numbers and letters that Steven can get when he selects one ball from each bag.

1 A	2 A	3 A
1 B	2 B	3 B
1 C	2 C	3 C
1 D	2 D	3 D

When Steven randomly selects one ball from each bag, what is the probability that he will select a table-tennis ball with a 1 on it and also a table-tennis ball with a B on it?

- A. $\frac{1}{12}$
- B. $\frac{1}{11}$
- C. $\frac{1}{4}$
- D. $\frac{1}{3}$

14 A bottle contains 0.375 liters of juice. Which of the following is another way to express 0.375?

- A. $\frac{3}{75}$
- B. $\frac{3}{8}$
- C. $\frac{37}{50}$
- D. $\frac{3}{4}$

15 The stem-and-leaf plot below shows the ages, in years, of people who attended the mayor’s speech yesterday.

**Ages, in Years, of People
Who Attended Mayor’s Speech**

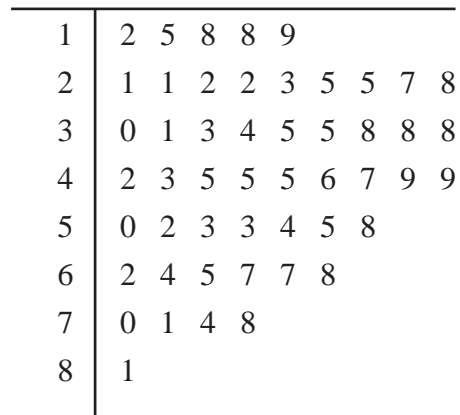

Key
2 4 represents 24

What is the total number of people younger than 30 years old who attended the speech?

- A. 10
- B. 14
- C. 15
- D. 23

- 16 The graph below represents the cost of purchasing different numbers of tickets to a school play.

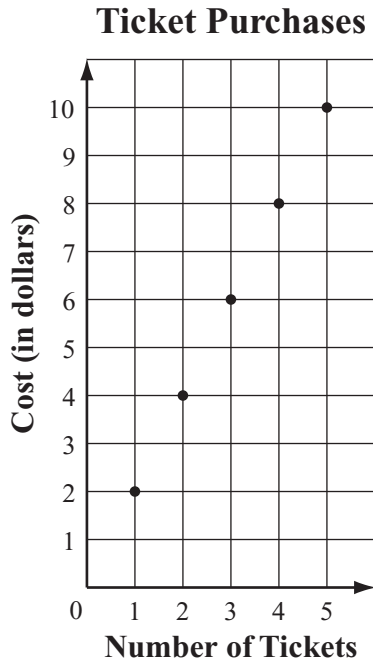

As the number of tickets purchased increases by 1, how does the cost of the ticket purchase change?

- A. It increases by \$0.50.
- B. It increases by \$1.00.
- C. It increases by \$2.00.
- D. It increases by \$4.00.

- 17 Hani divided a board that is 52 inches long into two equal pieces. To find the length of each piece, she used the division expression below.

$$52 \div 2$$

Which of the following expressions can also be used to find the length of each piece?

- A. 2×52
- B. $2 \div 52$
- C. $52 \times \frac{1}{2}$
- D. $52 \div \frac{1}{2}$

- 18 What is the value of the expression below when $x = 4$ and $y = 2$?

$$x^3 - 3y$$

- A. 58
- B. 32
- C. 10
- D. 6

Questions 19 and 20 are short-answer questions. Write your answers to these questions in the boxes provided in your Student Answer Booklet. Do not write your answers in this test booklet. You may do your figuring in the test booklet.

- 19 All of the sweaters in a store are on sale for 10% less than the regular price. What is the sale price of a sweater with a regular price of \$38?

- 20 What value of x makes the equation below true?

$$5x - 1 = 19$$

Question 21 is a short-answer question. Write your answer to this question in the box provided in your Student Answer Booklet. Do not write your answer in this test booklet. You may do your figuring in the test booklet.

- 21 The figure below shows two intersecting lines.

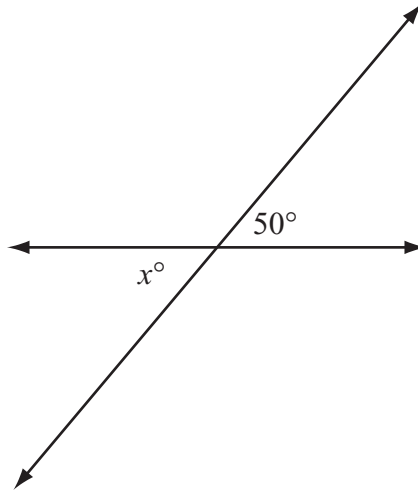

Based on the given angle measure, what is the value of x ?

Question 22 is an open-response question.

- **BE SURE TO ANSWER AND LABEL ALL PARTS OF THE QUESTION.**
- **Show all your work (diagrams, tables, or computations) in your Student Answer Booklet.**
- **If you do the work in your head, explain in writing how you did the work.**

Write your answer to question 22 in the space provided in your Student Answer Booklet.

22 Mary took 7 hours to read a biography that had 210 pages.

- a. What was Mary’s average reading rate, in pages per hour? Show or explain how you got your answer.
- b. In your Student Answer Booklet, copy the table below, and complete it using Mary’s average reading rate from part (a).

Mary’s Reading Rate

Number of Hours (x)	Number of Pages (y)
1	
2	
3	
4	

- c. Write an equation that represents the relationship between x , the number of hours Mary read, and y , the number of pages she read.
- d. How long will it take Mary to read 80 pages at the same average reading rate? Show or explain how you got your answer.

Mathematics

SESSION 2

You may use your reference sheet and MCAS ruler during this session.

You may use a calculator during this session.



DIRECTIONS

This session contains fourteen multiple-choice questions and three open-response questions. Mark your answers to these questions in the spaces provided in your Student Answer Booklet.

- 23 The list below shows the number of minutes that Katie played in each basketball game last season.

35, 13, 34, 25, 35, 26

What was the mean number of minutes that Katie played per game?

- A. 22 minutes
- B. 28 minutes
- C. 30 minutes
- D. 35 minutes

- 24 Valerie and Grace have part-time jobs. Valerie earns \$2 less per hour than Grace earns.

Let g represent Grace's hourly wage in dollars. Which of the following expressions represents Valerie's hourly wage?

- A. $2g$
- B. $2 - g$
- C. $g - 2$
- D. $g \div 2$

- 25 The principal of Washington Middle School surveyed students to determine how they got home from school on Monday. The graph below shows the results of this survey.

Students' Transportation from School on Monday

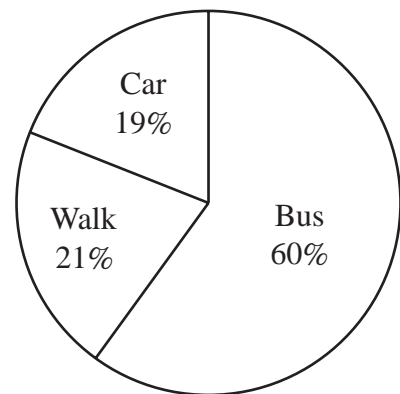

Of the students surveyed, 63 students said they walked home from school on Monday. What was the total number of students surveyed?

- A. 63
- B. 189
- C. 210
- D. 300

- 26 The graph below shows a relationship between values of x and y .

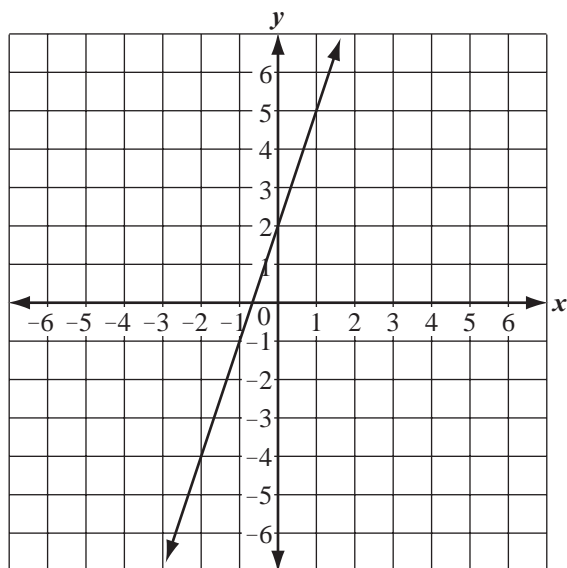

As the value of x increases from 0 to 1, what is the change in the value of y ?

- A. The value of y increases by 3.
- B. The value of y decreases by 3.
- C. The value of y increases by $\frac{1}{3}$.
- D. The value of y decreases by $\frac{1}{3}$.

- 27 The interior of a picnic cooler is in the shape of a rectangular prism.

- It has a width of 6 inches.
- It has a length of 8 inches.
- It has a volume of 336 cubic inches.

What is the height of the interior of the picnic cooler?

- A. 4 inches
- B. 6 inches
- C. 7 inches
- D. 8 inches

Questions 28 and 29 are open-response questions.

- **BE SURE TO ANSWER AND LABEL ALL PARTS OF EACH QUESTION.**
- **Show all your work (diagrams, tables, or computations) in your Student Answer Booklet.**
- **If you do the work in your head, explain in writing how you did the work.**

Write your answer to question 28 in the space provided in your Student Answer Booklet.

- 28** Ms. Larson gave a mathematics test to nine of the students in her class. Each student's score is listed in the box below.

85, 77, 88, 52, 82, 95, 93, 77, 80

- Make a stem-and-leaf plot for these test scores. Be sure to include a key.
- What is the median of these test scores? Show or explain how you got your answer.
- The test score of one more student was added to the list. With the new score included, the median is 83. What score was added to the list? Show or explain how you got your answer.

Write your answer to question 29 in the space provided in your Student Answer Booklet.

- 29 The figure below is a rectangle with a semicircle at one of its ends.

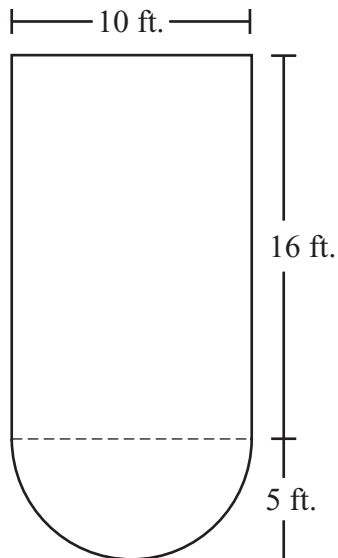

The radius of the semicircle is 5 feet, and the dimensions of the rectangle are 10 feet by 16 feet.

- What is the diameter, in feet, of the semicircle? Show or explain how you got your answer.
- What is the length, in feet, of the curved part of the semicircle? Show or explain how you got your answer. (Use 3.14 for π .)
- What is the perimeter, in feet, of the figure? Show or explain how you got your answer.

Mark your answers to multiple-choice questions 30 through 38 in the spaces provided in your Student Answer Booklet. Do not write your answers in this test booklet. You may do your figuring in the test booklet.

- 30 Serita counted her heartbeats after running. In 15 seconds, she counted 33 heartbeats. At that rate, what was her number of heartbeats per **minute**?
- A. 132
B. 220
C. 273
D. 495
- 31 The price that Economy Lawn Mowing charges to mow a lawn is equal to $\frac{2}{3}$ of the price charged by Farrell's Lawn Service.
- If a represents the price charged by Farrell's Lawn Service, which of the following expressions represents the price that Economy Lawn Mowing charges?
- A. $a - \frac{2}{3}$
B. $a + \frac{2}{3}$
C. $a \times \frac{2}{3}$
D. $a \div \frac{2}{3}$
- 32 Mary's chores include taking out the trash every third day and washing the dishes every fourth day. She took out the trash **and** washed the dishes on February 7.
- Based on Mary's schedule for doing chores, what is the next date that she will do both chores on the same day?
- A. February 10
B. February 12
C. February 14
D. February 19
- 33 A speedboat can travel at a rate of 40 miles per hour. At this rate, what is the distance that the speedboat will travel in 6 minutes?
- A. 2.4 miles
B. 4.0 miles
C. 6.7 miles
D. 9.0 miles

34 In her pocket, Sheena has one state quarter for each of the states listed below.

- Massachusetts (MA)
- Connecticut (CT)
- New York (NY)
- Vermont (VT)

She randomly selects a quarter and returns it to her pocket. Then she does this a second time. The tree diagram below shows all of the possible combinations of quarters that Sheena can select.

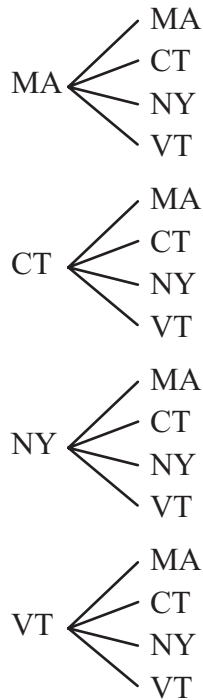

What is the probability that Sheena will select the Massachusetts quarter both times?

- A. $\frac{1}{16}$
- B. $\frac{1}{4}$
- C. $\frac{1}{3}$
- D. $\frac{1}{2}$

35 The flow rate of a river was measured in cubic feet per second at the same time each day over a five-day period. The table below lists the flow rates.

River Flow Rates



Day	Flow Rate (cubic feet per second)
1	145
2	150
3	145
4	149
5	136

What is the range of the river’s flow rates, in cubic feet per second, for these five days?











- A. 150
- B. 136
- C. 14
- D. 9

- 36 At Burger Shack, the price of 2 hamburgers and 2 orders of fries is equal to the price of 3 hamburgers, as modeled below.

$$\text{hamburger} + \text{hamburger} + \text{fries} + \text{fries} = \text{hamburger} + \text{hamburger} + \text{hamburger}$$

Key	
	represents the cost of a hamburger
	represents the cost of an order of fries

Which of the following equations models the price of an order of fries in terms of the price of a hamburger at Burger Shack?

- A.  = 
- B.  = 
- C.  =  + 
- D.  =  + 

- 37 A new house was built on a lot in the shape of a trapezoid, as shown below.

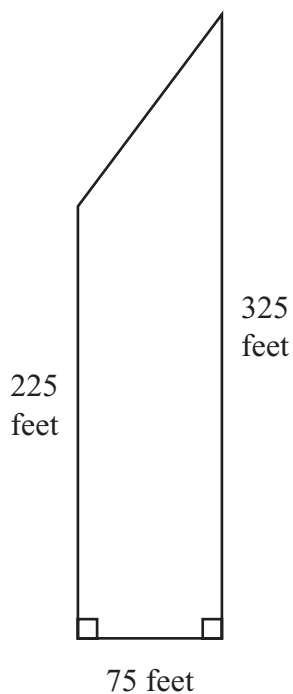

What is the area of the trapezoid?

- A. 16,875 square feet
- B. 17,200 square feet
- C. 20,625 square feet
- D. 24,375 square feet

- 38 Jamie made 7 paper airplanes in 2 minutes. She wants to make 10 paper airplanes.

If Jamie works at the same rate, which of the following proportions can be used to determine x , the number of minutes it will take her to make 10 paper airplanes?

- A. $\frac{1}{10} = \frac{x}{2 + 7}$
- B. $\frac{10}{1} = \frac{x}{2 + 7}$
- C. $\frac{7}{2} = \frac{10}{x}$
- D. $\frac{2}{7} = \frac{10}{x}$

Question 39 is an open-response question.

- **BE SURE TO ANSWER AND LABEL ALL PARTS OF THE QUESTION.**
- **Show all your work (diagrams, tables, or computations) in your Student Answer Booklet.**
- **If you do the work in your head, explain in writing how you did the work.**

Write your answer to question 39 in the space provided in your Student Answer Booklet.

- 39 Copy the x -axis and y -axis shown below onto the grid in your Student Answer Booklet.

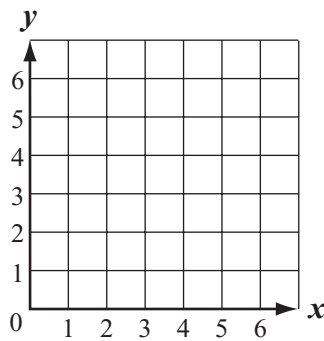

- Plot and label point $P(4, 6)$ and point $Q(4, 2)$ on your grid.
- Line segment PQ is one side of a rectangle. On your grid, draw rectangle $PQRS$ with a length of 4 units and a width of 2 units.
 - Label point R and point S .
 - Write the coordinates of point R and point S .
- On your grid, draw the two diagonals of rectangle $PQRS$. What are the coordinates of the point where the two diagonals intersect?

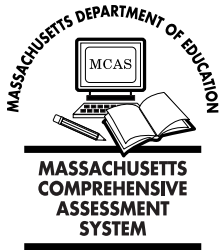

Massachusetts Comprehensive Assessment System Grade 7 Mathematics Reference Sheet

PERIMETER FORMULAS

square $P = 4s$

rectangle $P = 2b + 2h$

OR

$$P = 2l + 2w$$

triangle $P = a + b + c$

AREA FORMULAS

square $A = s^2$

rectangle $A = bh$

OR

$$A = lw$$

parallelogram $A = bh$

triangle $A = \frac{1}{2}bh$

trapezoid $A = \frac{1}{2}h(b_1 + b_2)$

circle $A = \pi r^2$

TOTAL SURFACE AREA FORMULAS

rectangular prism $SA = 2(lw) + 2(hw) + 2(lh)$

cylinder $SA = 2\pi r^2 + 2\pi rh$

VOLUME FORMULAS

rectangular prism $V = lwh$

OR

$$V = Bh$$

(B = area of a base)

cube $V = s^3$

(s = length of an edge)

cylinder $V = \pi r^2 h$

CIRCLE FORMULAS

$$C = 2\pi r$$

OR

$$C = \pi d$$

$$A = \pi r^2$$

Grade 7 Mathematics
Spring 2007 Released Items:
Reporting Categories, Standards, and Correct Answers

Item No.	Page No.	Reporting Category	Standard	Correct Answer (MC/SA)*
1	329	<i>Patterns, Relations, and Algebra</i>	7.P.1	C
2	329	<i>Number Sense and Operations</i>	7.N.5	D
3	329	<i>Number Sense and Operations</i>	7.N.3	B
4	330	<i>Geometry</i>	7.G.6	C
5	331	<i>Measurement</i>	7.M.1	D
6	331	<i>Number Sense and Operations</i>	7.N.4	C
7	332	<i>Geometry</i>	7.G.1	70
8	332	<i>Patterns, Relations, and Algebra</i>	7.P.5	$c = 5t$ or equivalent
9	333	<i>Number Sense and Operations</i>	7.N.9	
10	334	<i>Number Sense and Operations</i>	7.N.7	B
11	334	<i>Data Analysis, Statistics, and Probability</i>	7.D.1	D
12	335	<i>Number Sense and Operations</i>	7.N.8	B
13	335	<i>Data Analysis, Statistics, and Probability</i>	7.D.3	A
14	336	<i>Number Sense and Operations</i>	7.N.1	B
15	336	<i>Data Analysis, Statistics, and Probability</i>	7.D.1	B
16	337	<i>Patterns, Relations, and Algebra</i>	7.P.5	C
17	337	<i>Number Sense and Operations</i>	7.N.6	C
18	337	<i>Patterns, Relations, and Algebra</i>	7.P.2	A
19	338	<i>Number Sense and Operations</i>	7.N.9	\$34.20
20	338	<i>Patterns, Relations, and Algebra</i>	7.P.4	4
21	339	<i>Geometry</i>	7.G.3	50
22	340	<i>Patterns, Relations, and Algebra</i>	7.P.3	
23	341	<i>Data Analysis, Statistics, and Probability</i>	7.D.2	B
24	341	<i>Patterns, Relations, and Algebra</i>	7.P.3	C
25	341	<i>Data Analysis, Statistics, and Probability</i>	7.D.1	D
26	342	<i>Patterns, Relations, and Algebra</i>	7.P.5	A
27	342	<i>Measurement</i>	7.M.3	C
28	343	<i>Data Analysis, Statistics, and Probability</i>	7.D.2	
29	344	<i>Measurement</i>	7.M.3	
30	345	<i>Number Sense and Operations</i>	7.N.2	A
31	345	<i>Patterns, Relations, and Algebra</i>	7.P.3	C
32	345	<i>Patterns, Relations, and Algebra</i>	7.P.1	D
33	345	<i>Number Sense and Operations</i>	7.N.2	B
34	346	<i>Data Analysis, Statistics, and Probability</i>	7.D.3	A
35	346	<i>Data Analysis, Statistics, and Probability</i>	7.D.2	C
36	347	<i>Patterns, Relations, and Algebra</i>	7.P.4	A
37	348	<i>Measurement</i>	7.M.3	C
38	348	<i>Patterns, Relations, and Algebra</i>	7.P.6	C
39	349	<i>Geometry</i>	7.G.4	

* Answers are provided here for multiple-choice items and short-answer items only. Sample responses and scoring guidelines for open-response items, which are indicated by shaded cells, will be posted to the Department's Web site later this year.

XIV. Mathematics, Grade 8

Grade 8 Mathematics Test

The spring 2007 grade 8 MCAS Mathematics test was based on learning standards in the Massachusetts *Mathematics Curriculum Framework* (2000). The *Framework* identifies five major content strands, listed below.

- Number Sense and Operations
- Patterns, Relations, and Algebra
- Geometry
- Measurement
- Data Analysis, Statistics, and Probability

The grades 7–8 learning standards for each of these strands appear on pages 62–66 of the *Mathematics Curriculum Framework*, which is available on the Department Web site at www.doe.mass.edu/frameworks/current.html.

In *Test Item Analysis Reports* and on the Subject Area Subscore pages of the *MCAS School Reports* and *District Reports*, Mathematics test results are reported under five MCAS reporting categories, which are identical to the five *Framework* content strands listed above.

Test Sessions

The MCAS grade 8 Mathematics test included two separate test sessions. Each session included multiple-choice and open-response questions. Session 1 also included short-answer questions.

Reference Materials and Tools

Each student taking the grade 8 Mathematics test was provided with a plastic ruler and a grade 8 Mathematics Reference Sheet. A copy of the reference sheet follows the final question in this chapter. An image of the ruler is not reproduced in this publication.

During session 2, each student had sole access to a calculator with at least four functions and a square root key. Calculator use was not allowed during session 1.

The use of bilingual word-to-word dictionaries was allowed for current and former limited English proficient students only, during both Mathematics test sessions. No other reference tools or materials were allowed.

Cross-Reference Information

The table at the conclusion of this chapter indicates each item's reporting category and the *Framework* learning standard it assesses. The correct answers for multiple-choice and short-answer questions are also displayed in the table.

Mathematics

SESSION 1

You may use your reference sheet and MCAS ruler during this session.
You may **not** use a calculator during this session.



DIRECTIONS

This session contains fifteen multiple-choice questions, five short-answer questions, and two open-response questions. Mark your answers to these questions in the spaces provided in your Student Answer Booklet.

- 1 Samir made a pattern by starting with 9 and repeatedly dividing by 3, as shown below.

$$9, 3, 1, \frac{1}{3}, ?, \frac{1}{27}, \dots$$

What number belongs in the position indicated by the question mark?

- A. $\frac{1}{6}$
- B. $\frac{1}{9}$
- C. $\frac{1}{12}$
- D. $\frac{1}{18}$

- 2 Between which two consecutive integers on the number line does $\sqrt{11}$ lie?

- A. 3 and 4
- B. 5 and 6
- C. 11 and 12
- D. 22 and 23

- 3 The graph below shows the distance an airplane traveled over time.

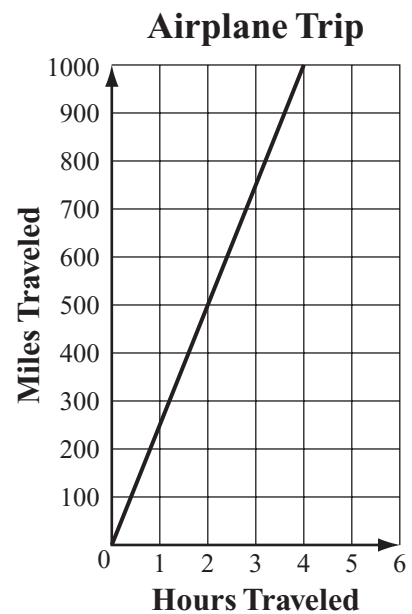

Which of the following is closest to the average speed of the airplane?

- A. 100 miles per hour
- B. 250 miles per hour
- C. 500 miles per hour
- D. 1000 miles per hour

4 The minimum distance from Neptune to Earth is about 2.68 billion miles. What is 2.68 billion written in scientific notation?

- A. 2.68×10^6
- B. 2.68×10^7
- C. 2.68×10^9
- D. 2.68×10^{10}

5 What is the value of the expression below?

$$|15| + |-10|$$

- A. -25
- B. -5
- C. 5
- D. 25

6 The floor of the lobby of a theater is shaped like a rectangle, as shown below.

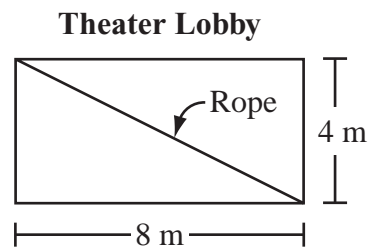

Before a performance starts, a velvet rope is stretched diagonally across the lobby. Which of the following best describes the diagonal length of the lobby?

- A. between 8 and 9 meters
- B. between 9 and 10 meters
- C. between 10 and 11 meters
- D. between 11 and 12 meters

Questions 7 and 8 are short-answer questions. Write your answers to these questions in the boxes provided in your Student Answer Booklet. Do not write your answers in this test booklet. You may do your figuring in the test booklet.

- 7 In the figure below, parallel lines l and m are intersected by transversal p .

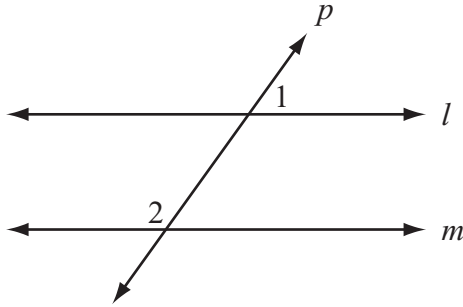

If the measure of $\angle 1$ is 50° , what is the degree measure of $\angle 2$?

- 8 A large jet has a wingspan of $87\frac{1}{3}$ yards, as shown below.

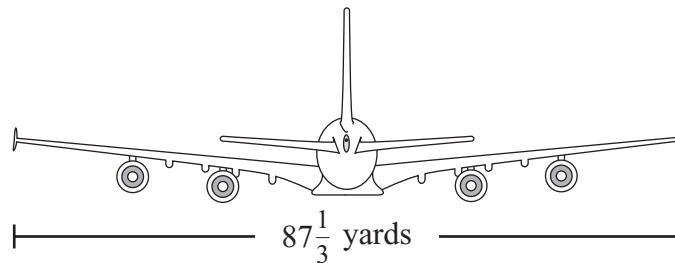

What is the wingspan, in feet, of the jet?

Question 9 is an open-response question.

- **BE SURE TO ANSWER AND LABEL ALL PARTS OF THE QUESTION.**
- **Show all your work (diagrams, tables, or computations) in your Student Answer Booklet.**
- **If you do the work in your head, explain in writing how you did the work.**

Write your answer to question 9 in the space provided in your Student Answer Booklet.

- 9** Marisa drank one cup of milk and ate x small vanilla cookies for a snack. The linear equation below represents y , the total number of calories in Marisa's snack.

$$y = 12x + 120$$

- What is the y -intercept of the line represented by this equation?
- Explain what the y -intercept tells us about Marisa's snack.
- What is the slope of the line represented by this equation?
- Explain what the slope tells us about Marisa's snack.
- If Marisa eats 9 small vanilla cookies, what is the total number of calories in her snack? Show or explain how you got your answer.

Mark your answers to multiple-choice questions 10 through 18 in the spaces provided in your Student Answer Booklet. Do not write your answers in this test booklet. You may do your figuring in the test booklet.

- 10 Which of the following graphs best represents the equation below?

$$y = -2x + 1$$

A.

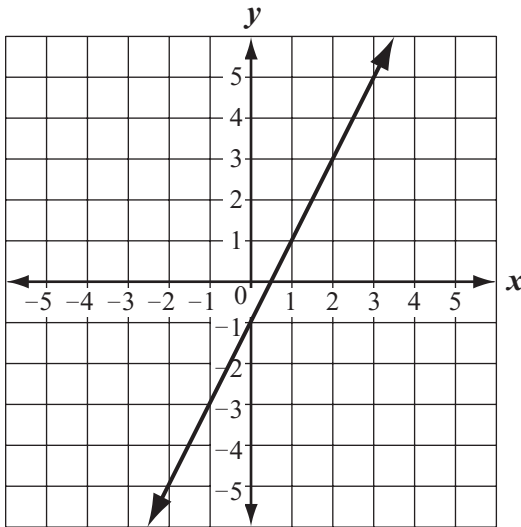

C.

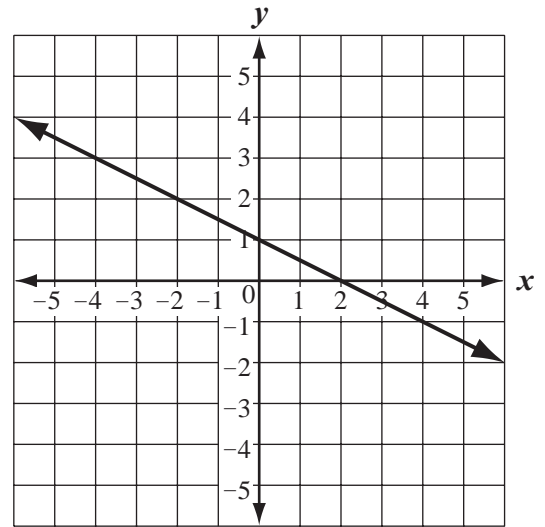

B.

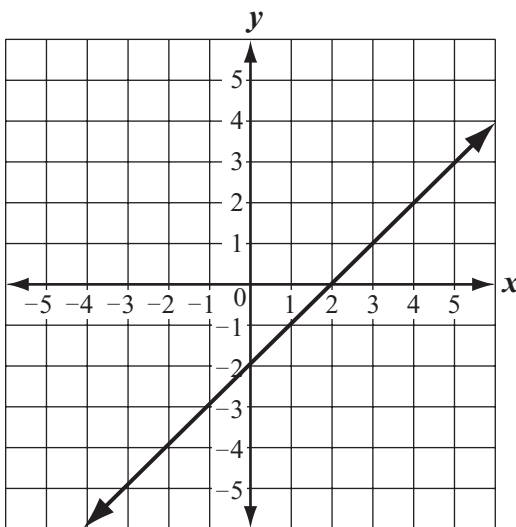

D.

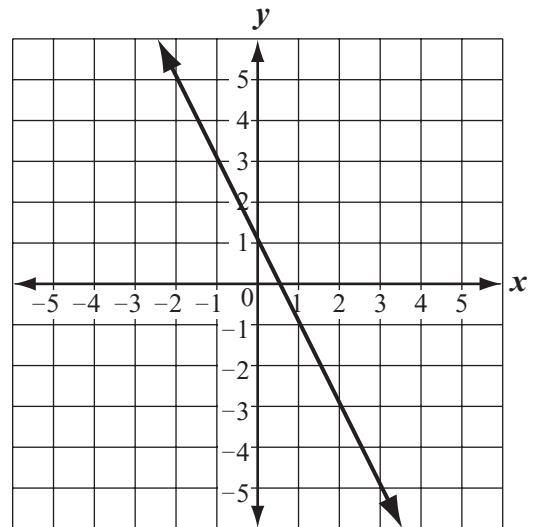

11 Mr. Lee has one mathematics class with 16 students and one with 24 students. He wants to divide each class into groups with the same number of students in each group. What is the greatest number of students Mr. Lee can have in each group?

- A. 2
- B. 4
- C. 6
- D. 8

12 Which of the following is equivalent to the expression below?

$$3(1.50) + 3(2.50)$$

- A. $3(1.50 + 2.50)$
- B. $3(1.50)(2.50)$
- C. $3(1.50 + 3)2.50$
- D. $3(3) + (1.50)(2.50)$

13 Abe tested 85 Brand X light bulbs to determine their life spans. The histogram below shows the results of his test.

**Life Spans of
85 Brand X Light Bulbs**

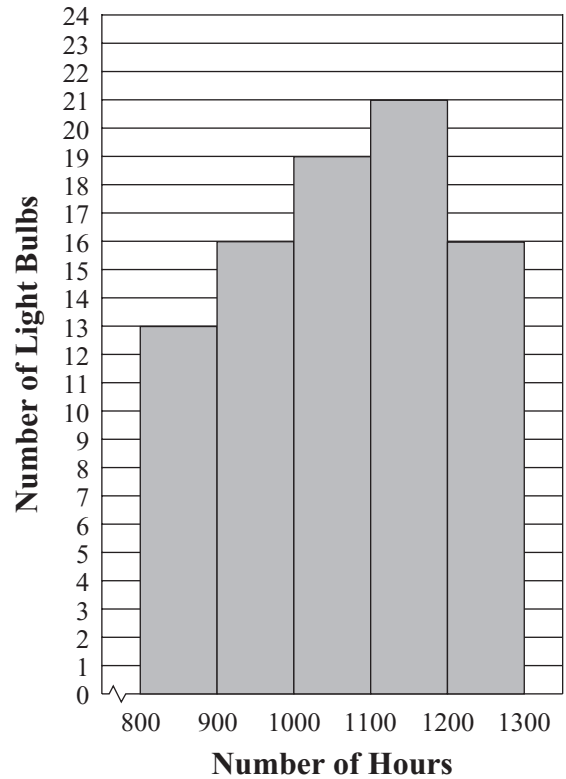

What was the total number of Brand X light bulbs that had life spans greater than or equal to 1000 hours?

- A. 72
- B. 56
- C. 51
- D. 21

- 14 Which of the following is equivalent to the expression below?

$$-2(x - 3)$$

- A. $x - 5$
- B. $x + 6$
- C. $-2x - 5$
- D. $-2x + 6$

- 15 Which of the following is equivalent to the expression below?

$$\frac{2}{3} \div \frac{3}{4}$$

- A. $\frac{2}{3} \div \frac{4}{3}$
- B. $\frac{2}{3} \cdot \frac{4}{3}$
- C. $\frac{3}{2} \div \frac{3}{4}$
- D. $\frac{3}{2} \cdot \frac{3}{4}$

- 16 The table below shows the relationship between the number of a term in a pattern and the value of that term. The same rule is used to find the value of the term in each row.

Term Number	Value of Term
1	3
2	5
3	7
4	9
n	?

Based on the pattern shown in the table, which of the following expressions could represent the value of the n th term?

- A. $3n$
- B. $n + 2$
- C. $n + 5$
- D. $2n + 1$

17 Which of the following lines appears to have a y-intercept of 4 and a slope of $\frac{1}{3}$?

A.

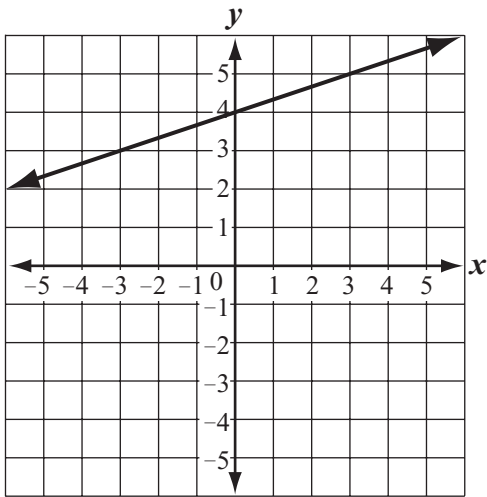

C.

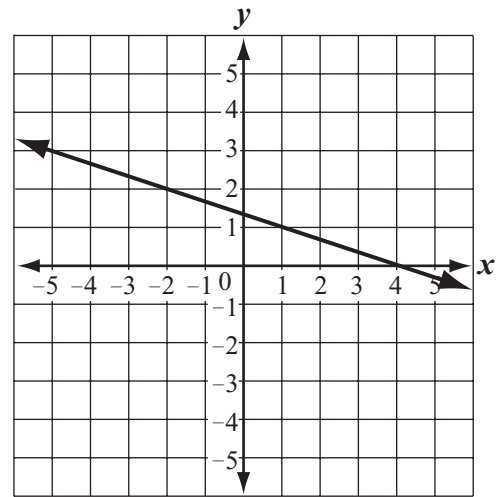

B.

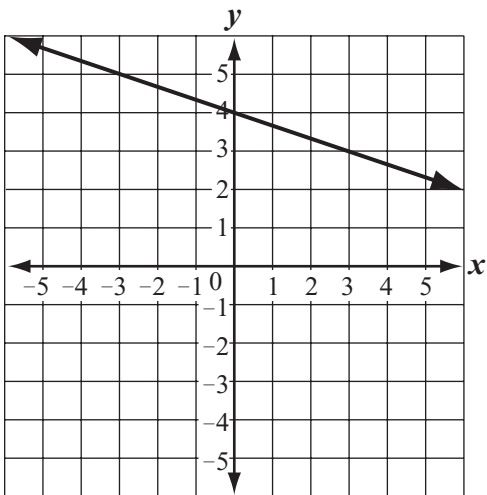

D.

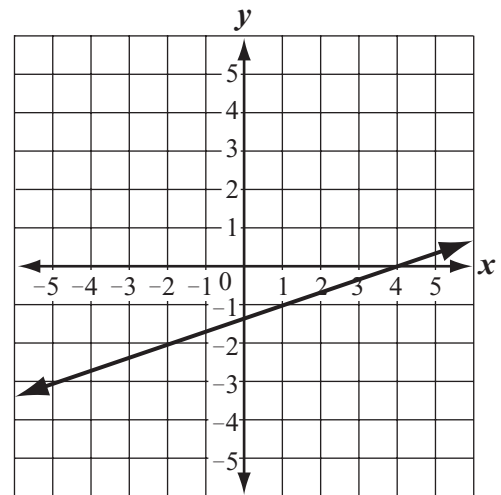

- 18 What is the value of the expression below?

$$\sqrt{36} + 13 \cdot 2$$

- A. 32
- B. 38
- C. 62
- D. 98

Questions 19 and 20 are short-answer questions. Write your answers to these questions in the boxes provided in your Student Answer Booklet. Do not write your answers in this test booklet. You may do your figuring in the test booklet.

- 19 A shipping box is in the shape of a rectangular prism, as shown below.

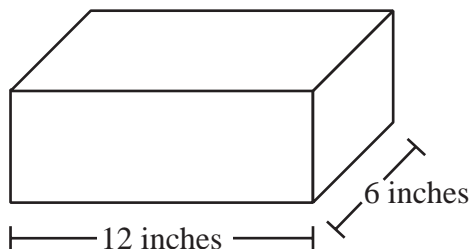

- It has a length of 12 inches.
- It has a width of 6 inches.
- It has a volume of 288 cubic inches.

What is the height, in inches, of the shipping box?

- 20 Mr. Johnson noted that $\frac{3}{8}$ of the students at his school were in the band. He also noted that $\frac{1}{2}$ of the students in the band were girls. What fractional part of the students at the school were girls in the band?

Question 21 is a short-answer question. Write your answer to this question in the box provided in your Student Answer Booklet. Do not write your answer in this test booklet. You may do your figuring in the test booklet.

- 21** What is the value of x that makes the equation below true?

$$2x - 3 = 11$$

Question 22 is an open-response question.

- **BE SURE TO ANSWER AND LABEL ALL PARTS OF THE QUESTION.**
- **Show all your work (diagrams, tables, or computations) in your Student Answer Booklet.**
- **If you do the work in your head, explain in writing how you did the work.**

Write your answer to question 22 in the space provided in your Student Answer Booklet.

- 22 Mora bought a box of cereal that was a rectangular prism with a length of 7.5 inches, a width of 2.5 inches, and a height of 11 inches, as shown below.

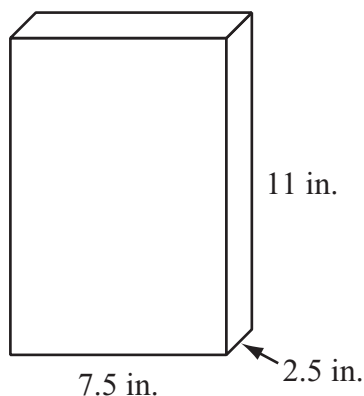

- a. What is the total number of vertices of Mora's cereal box? Show or explain how you got your answer.
- b. What is the total number of faces of Mora's cereal box? Show or explain how you got your answer.
- c. In your Student Answer Booklet, draw a net (flat pattern) that can be folded to form a box with the same dimensions as Mora's cereal box. Be sure to label your drawing of the net with the lengths, in inches, of the line segments.

Mathematics

SESSION 2

You may use your reference sheet and MCAS ruler during this session.

You may use a calculator during this session.



DIRECTIONS

This session contains fourteen multiple-choice questions and three open-response questions. Mark your answers to these questions in the spaces provided in your Student Answer Booklet.

- 23 What is the value of the expression below when $x = 3$ and $y = 5$?

$$2x^2 + 3y$$

- A. 27
- B. 33
- C. 51
- D. 53

- 24 Tuan answered 20 customer service calls in 3 hours. At this rate, how many customer service calls can Tuan answer in 7.5 hours?

- A. 45
- B. 50
- C. 60
- D. 80

- 25 Intersecting sidewalks surround a playground shaped like a quadrilateral, as shown in the diagram below.

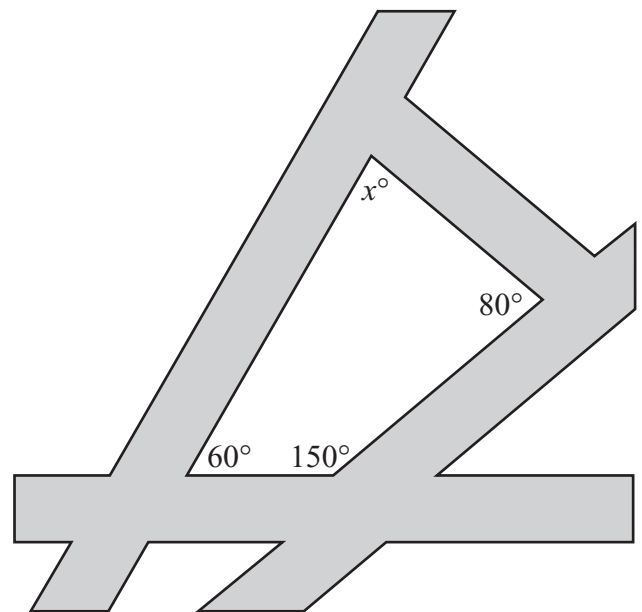

Based on the angle measures in the diagram, what is the value of x ?

- A. 70
- B. 80
- C. 120
- D. 150

- 26 In David's school district, there is a positive correlation between the grade level and the weight of the mathematics textbook used by each grade.

Which of the following scatterplots best represents this correlation?

A. **Mathematics Textbooks**

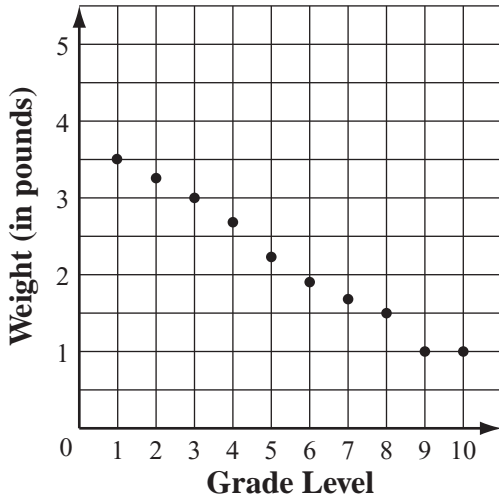

C. **Mathematics Textbooks**

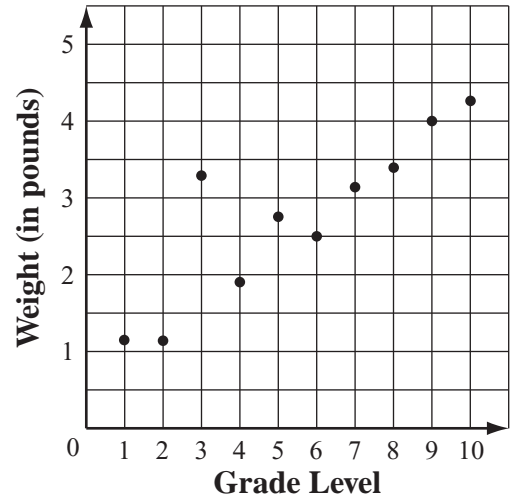

B. **Mathematics Textbooks**

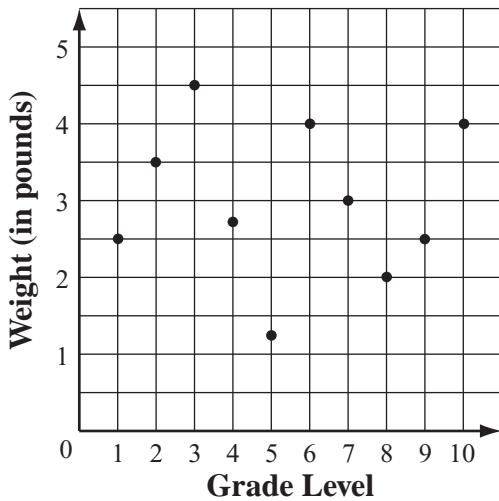

D. **Mathematics Textbooks**

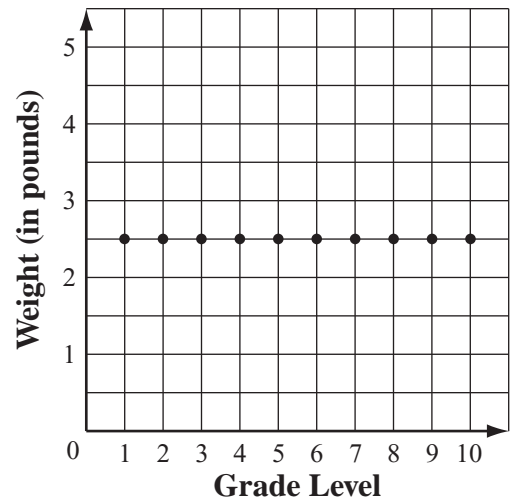

- 27 What is the slope of the line represented by the equation below?

$$y = \frac{1}{2}x + 3$$

- A. $\frac{1}{3}$
- B. $\frac{1}{2}$
- C. 2
- D. 3

Questions 28 and 29 are open-response questions.

- **BE SURE TO ANSWER AND LABEL ALL PARTS OF EACH QUESTION.**
- **Show all your work (diagrams, tables, or computations) in your Student Answer Booklet.**
- **If you do the work in your head, explain in writing how you did the work.**

Write your answer to question 28 in the space provided in your Student Answer Booklet.

28 A florist sells bouquets of carnations. He creates bouquets of different sizes by using 4 white carnations for every 3 pink carnations in a bouquet.

- Write a proportion that can be used to find p , the number of pink carnations in a bouquet with w white carnations.
- What is the number of pink carnations in a bouquet with 16 white carnations? Show or explain how you got your answer.
- The florist made a bouquet with a total of 35 carnations in it.
 - What is the total number of pink carnations in the bouquet?
 - What is the total number of white carnations in the bouquet?

Show or explain how you got your answers.

Write your answer to question 29 in the space provided in your Student Answer Booklet.

29 A rancher has two water tanks.

- Each water tank is in the shape of a cylinder.
- The base of each water tank is in the shape of a circle.

Diagrams of the two water tanks are shown below.

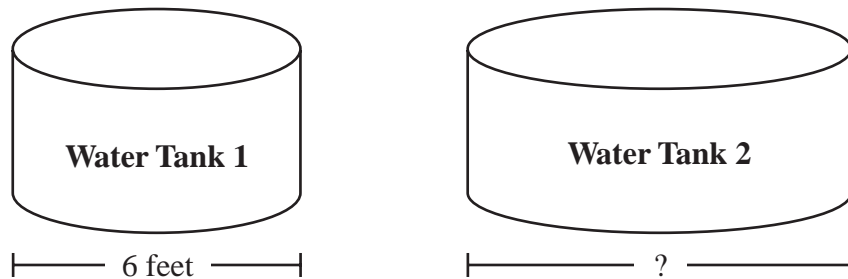

- What is the circumference, in feet, of the base of Water Tank 1? Show or explain how you got your answer. (Use 3.14 for π .)
- The circumference of the base of Water Tank 2 is 6.28 feet longer than that of Water Tank 1. What is the diameter, in feet, of the base of Water Tank 2? Show or explain how you got your answer. (Use 3.14 for π .)
- How many more square feet does the base of Water Tank 2 cover than the base of Water Tank 1? Show or explain how you got your answer. (Use 3.14 for π .)

Mark your answers to multiple-choice questions 30 through 38 in the spaces provided in your Student Answer Booklet. Do not write your answers in this test booklet. You may do your figuring in the test booklet.

- 30 Ruben surveyed 180 students in his school to find each student’s favorite winter sport. He recorded his results in the circle graph below.

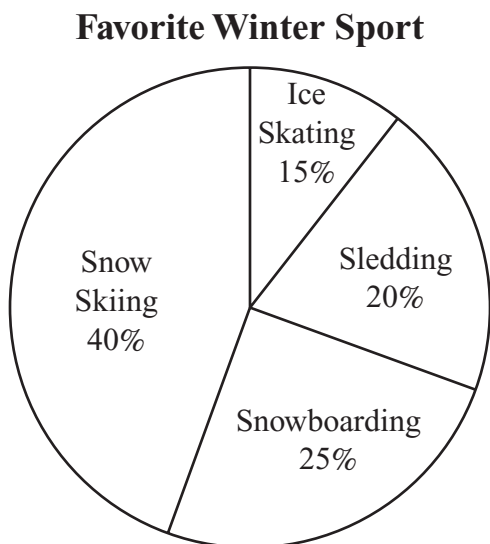

Based on Ruben’s graph, what is the total number of students whose favorite sport was either snowboarding or snow skiing?

- A. 117
- B. 115
- C. 90
- D. 65

- 31 Jaime used $5\frac{1}{2}$ tablespoons of lemonade mix to make 2 quarts of lemonade. At this rate, what is the total number of tablespoons of lemonade mix that Jaime will use to make 3 quarts of lemonade?

- A. $6\frac{1}{2}$
- B. $8\frac{1}{4}$
- C. $10\frac{1}{2}$
- D. $16\frac{1}{4}$

- 32 Andrea went to an amusement park.
- The cost of admission was \$5.
 - The cost for each ride was \$0.75.

The equation below shows c , Andrea's total cost to go to the amusement park and go on r rides.

$$c = 5 + 0.75r$$

Based on the equation, which of the following statements is true?

- A. As the value of r increases, the value of c increases.
- B. As the value of r decreases, the value of c stays the same.
- C. As the value of c decreases, the value of r increases.
- D. As the value of c increases, the value of r stays the same.

- 33 Ms. Simmons made the box-and-whisker plot below to show some statistics about the ages of the students in her class at a community college.

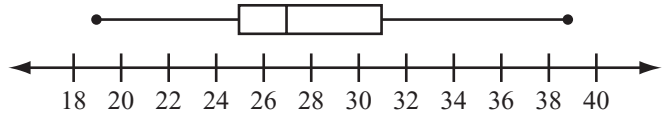

Ages of Students (in years)

Which of the following best represents the median age of the students in her class?

- A. 25
- B. 27
- C. 29
- D. 31

- 34 The directions for using a concentrated cleaning product say to add 3 capfuls of the product for every 2 quarts of water used. Which of the following equations can be used to calculate c , the number of capfuls of the product needed for 5 quarts of water?

A. $\frac{2}{3} = \frac{c}{5}$

B. $\frac{2}{3} = \frac{c}{7}$

C. $\frac{3}{2} = \frac{c}{5}$

D. $\frac{3}{2} = \frac{c}{7}$

- 35 Tara wrote a set of three numbers.

- The mean of her set is 8.
- The range of her set is 14.

Which of the following could be Tara's set of numbers?

- A. 2, 8, 14
B. 4, 6, 18
C. 2, 6, 16
D. 6, 8, 10

- 36 Franco has a bag with four letter tiles in it. All of the tiles are the same size and shape, as shown below.



One face of each tile has a letter on it, and the other faces are blank.

Franco will select a tile at random, record the letter, and put the tile back. If he does this two times, what is the probability that Franco will select a T and then a B?

A. $\frac{1}{16}$

B. $\frac{1}{12}$

C. $\frac{1}{4}$

D. $\frac{1}{2}$

- 37 Amanda rents space at an outdoor market. Each month she pays the owner of the outdoor market \$79 plus 10 percent of s , her total monthly sales.

Which of the following expressions represents the total amount of money that Amanda pays the owner for one month?

- A. $79(0.1s)$
- B. $79s \div 0.1$
- C. $79s + 0.1$
- D. $79 + 0.1s$

- 38 The chart below shows the low temperatures, in degrees Fahrenheit, outside Maya's house for a seven-day period in December.

**Temperatures Outside
Maya's House**

Date	Temperature
December 12	-3°F
December 13	-9°F
December 14	8°F
December 15	7°F
December 16	-4°F
December 17	5°F
December 18	8°F

What is the median of the temperatures in the chart?

- A. 5°F
- B. 6°F
- C. 7°F
- D. 8°F

Question 39 is an open-response question.

- **BE SURE TO ANSWER AND LABEL ALL PARTS OF THE QUESTION.**
- **Show all your work (diagrams, tables, or computations) in your Student Answer Booklet.**
- **If you do the work in your head, explain in writing how you did the work.**

Write your answer to question 39 in the space provided in your Student Answer Booklet.

- 39 Brad made the Venn diagram below to show the number of cars in a parking lot that were red, had four doors, had a sunroof, or had any combination of those features. He left one number off his Venn diagram.

**Features of Cars
in Parking Lot**

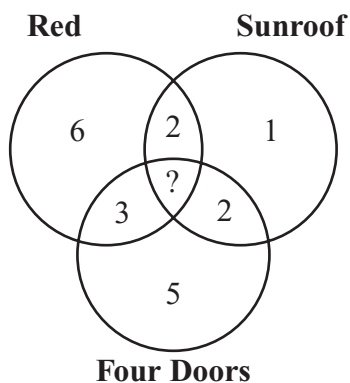

- Describe what the 6 represents in the Venn diagram.
- A total of 20 cars in the parking lot were red, had four doors, had a sunroof, or had any combination of those features. What number should Brad put in place of the “?” in the center section of his Venn diagram? Show or explain how you got your answer.
- What was the total number of cars in the parking lot that were red? Show or explain how you got your answer.



Massachusetts Comprehensive Assessment System Grade 8 Mathematics Reference Sheet

PERIMETER FORMULAS

square $P = 4s$

rectangle $P = 2b + 2h$

OR

$P = 2l + 2w$

triangle $P = a + b + c$

AREA FORMULAS

square $A = s^2$

rectangle $A = bh$

OR

$A = lw$

parallelogram $A = bh$

triangle $A = \frac{1}{2}bh$

trapezoid $A = \frac{1}{2}h(b_1 + b_2)$

circle $A = \pi r^2$

TOTAL SURFACE AREA FORMULAS

rectangular prism $SA = 2(lw) + 2(hw) + 2(lh)$

cylinder $SA = 2\pi r^2 + 2\pi rh$

sphere $SA = 4\pi r^2$

VOLUME FORMULAS

rectangular prism $V = lwh$

OR

$V = Bh$

($B =$ area of a base)

cube $V = s^3$

($s =$ length of an edge)

cylinder $V = \pi r^2 h$

sphere $V = \frac{4}{3}\pi r^3$

CIRCLE FORMULAS

$C = 2\pi r$

OR

$C = \pi d$

$A = \pi r^2$

PYTHAGOREAN THEOREM

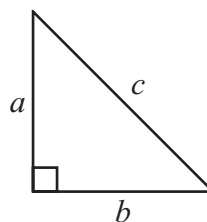

$a^2 + b^2 = c^2$

Grade 8 Mathematics
Spring 2007 Released Items:
Reporting Categories, Standards, and Correct Answers

Item No.	Page No.	Reporting Category	Standard	Correct Answer (MC/SA)*
1	355	<i>Patterns, Relations, and Algebra</i>	8.P.1	B
2	355	<i>Number Sense and Operations</i>	8.N.2	A
3	355	<i>Measurement</i>	8.M.5	B
4	356	<i>Number Sense and Operations</i>	8.N.4	C
5	356	<i>Number Sense and Operations</i>	8.N.6	D
6	356	<i>Geometry</i>	8.G.4	A
7	357	<i>Geometry</i>	8.G.3	130°
8	357	<i>Measurement</i>	8.M.1	262 feet
9	358	<i>Patterns, Relations, and Algebra</i>	8.P.6	
10	359	<i>Patterns, Relations, and Algebra</i>	8.P.7	D
11	360	<i>Number Sense and Operations</i>	8.N.5	D
12	360	<i>Number Sense and Operations</i>	8.N.8	A
13	360	<i>Data Analysis, Statistics, and Probability</i>	8.D.2	B
14	361	<i>Patterns, Relations, and Algebra</i>	8.P.3	D
15	361	<i>Number Sense and Operations</i>	8.N.9	B
16	361	<i>Patterns, Relations, and Algebra</i>	8.P.1	D
17	362	<i>Patterns, Relations, and Algebra</i>	8.P.10	A
18	363	<i>Number Sense and Operations</i>	8.N.7	A
19	364	<i>Measurement</i>	8.M.3	4 inches
20	364	<i>Number Sense and Operations</i>	8.N.10	$\frac{3}{16}$ or equivalent
21	365	<i>Patterns, Relations, and Algebra</i>	8.P.7	7
22	366	<i>Geometry</i>	8.G.8	
23	367	<i>Patterns, Relations, and Algebra</i>	8.P.2	B
24	367	<i>Number Sense and Operations</i>	8.N.3	B
25	367	<i>Geometry</i>	8.G.1	A
26	368	<i>Data Analysis, Statistics, and Probability</i>	8.D.2	C
27	369	<i>Patterns, Relations, and Algebra</i>	8.P.5	B
28	370	<i>Number Sense and Operations</i>	8.N.3	
29	371	<i>Measurement</i>	8.M.3	
30	372	<i>Data Analysis, Statistics, and Probability</i>	8.D.2	A
31	372	<i>Number Sense and Operations</i>	8.N.3	B
32	373	<i>Patterns, Relations, and Algebra</i>	8.P.8	A
33	373	<i>Data Analysis, Statistics, and Probability</i>	8.D.2	B
34	374	<i>Patterns, Relations, and Algebra</i>	8.P.9	C
35	374	<i>Data Analysis, Statistics, and Probability</i>	8.D.3	C
36	374	<i>Data Analysis, Statistics, and Probability</i>	8.D.4	A
37	375	<i>Patterns, Relations, and Algebra</i>	8.P.4	D
38	375	<i>Data Analysis, Statistics, and Probability</i>	8.D.3	A
39	376	<i>Data Analysis, Statistics, and Probability</i>	8.D.2	

* Answers are provided here for multiple-choice items and short-answer items only. Sample responses and scoring guidelines for open-response items, which are indicated by shaded cells, will be posted to the Department's Web site later this year.

XV. Mathematics, Grade 10

Grade 10 Mathematics Test

The spring 2007 grade 10 MCAS Mathematics test was based on learning standards in the Massachusetts *Mathematics Curriculum Framework* (2000). The *Framework* identifies five major content strands listed below.

- Number Sense and Operations
- Patterns, Relations, and Algebra
- Geometry
- Measurement
- Data Analysis, Statistics, and Probability

The grades 9–10 learning standards for each of these strands appear on pages 72–75 of the *Mathematics Curriculum Framework*, which is available on the Department Web site at www.doe.mass.edu/frameworks/current.html.

In *Test Item Analysis Reports* and on the Subject Area Subscore pages of the *MCAS School Reports* and *District Reports*, Mathematics test results are reported under five MCAS reporting categories, which are identical to the five *Framework* content strands listed above.

Test Sessions

The MCAS grade 10 Mathematics test included two separate test sessions, which were administered on consecutive days. Each session included multiple-choice and open-response questions. Session 1 also included short-answer questions.

Reference Materials and Tools

Each student taking the grade 10 Mathematics test was provided with a grade 10 Mathematics Reference Sheet. A copy of the reference sheet follows the final question in this chapter.

During session 2, each student had sole access to a calculator with at least four functions and a square root key. Calculator use was not allowed during session 1.

The use of bilingual word-to-word dictionaries was allowed for current and former limited English proficient students only, during both Mathematics test sessions. No other reference tools or materials were allowed.

Cross-Reference Information

The table at the conclusion of this chapter indicates each item's reporting category and the *Framework* learning standard it assesses. The correct answers for multiple-choice and short-answer questions are also displayed in the table.

Mathematics

SESSION 1

*You may use your reference sheet during this session.
You may **not** use a calculator during this session.*



DIRECTIONS

This session contains fourteen multiple-choice questions, four short-answer questions, and three open-response questions. Mark your answers to these questions in the spaces provided in your Student Answer Booklet.

- 1 What is the value of the expression below?

$$4(2^3 - 7) - 5^2$$

- A. -21
- B. -14
- C. 1
- D. 29

- 2 Which of the following is closest to the value of $\sqrt{140}$?

- A. 11
- B. 12
- C. 70
- D. 72

- 3 The number of points scored by the Springdale Hawks in each of their last ten basketball games is shown in the stem-and-leaf plot below.

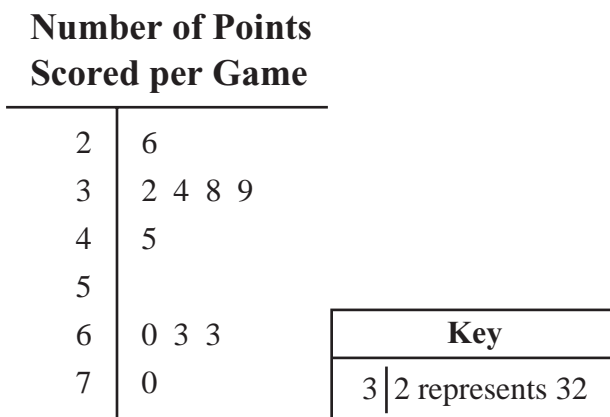

What is the median number of points scored per game by the Hawks?

- A. 42
- B. 44
- C. 45
- D. 47

- 4 Which of the following is equivalent to the expression below?

$$(3x - 2)(2x + 3)$$

- A. $5x^2 + 5x + 1$
- B. $5x^2 + 13x + 1$
- C. $6x^2 + 13x - 6$
- D. $6x^2 + 5x - 6$

- 5 What is the value of the expression below?

$$\frac{8 + 6 \cdot 4}{48 \div 6 - 4}$$

- A. $\frac{4}{3}$
- B. $\frac{7}{3}$
- C. 8
- D. 14

- 6 The table below shows a relationship between values of x and y .

x	1	2	3	4	5
y	3	6	11	18	27

Which of the following equations describes the relationship between x and y for the values in the table?

- A. $y = 3x$
- B. $y = 5x - 2$
- C. $y = x^2 + 2$
- D. $y = x^3$

- 7 Which of the following statements is true?

- A. $\pi = \sqrt{8}$
- B. $\pi > \sqrt{8}$
- C. $\pi = \sqrt{12}$
- D. $\pi > \sqrt{12}$

- 8 Which of the following is equivalent to the expression below?

$$(5x + 6y - 3z) + (3x - 8y + z)$$

- A. $8x - 14y - 4z$
- B. $8x - 2y - 2z$
- C. $8x - 14y - 2z$
- D. $8x - 2y - 3z$

- 9 Which of the following is closest to the cube root of 150?

- A. 5
- B. 12
- C. 15
- D. 50

- 10 Which of the following scatterplots is most likely to have a line of best fit represented by the equation below?

$$y = -5x + 2$$

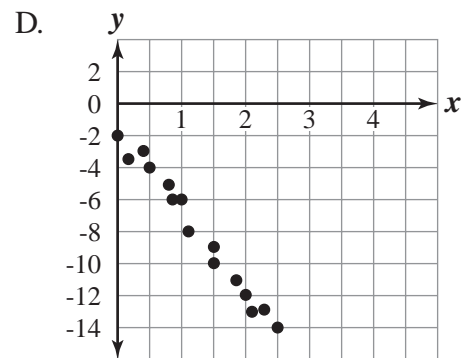
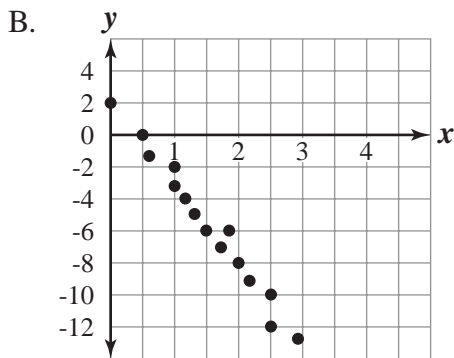
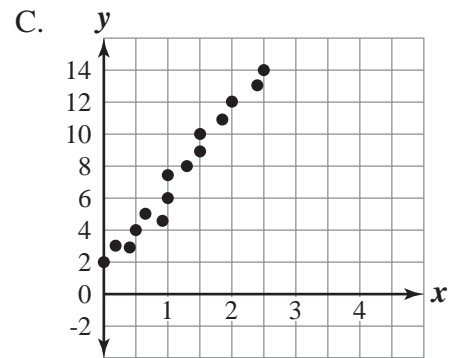
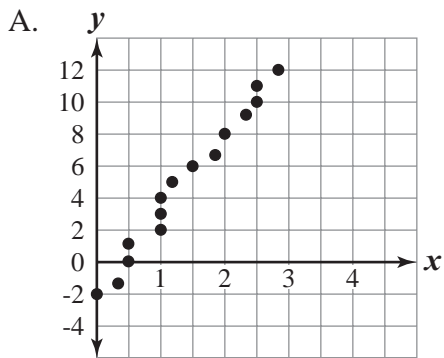

- 11 What are **all** the values of x that make the quadratic equation below true?

$$x^2 - 16 = 0$$

- A. $x = 4$
- B. $x = 8$
- C. $x = 4$ or $x = -4$
- D. $x = 8$ or $x = -8$

- 12 The line segments in the diagram below represent the paths through a rose garden.

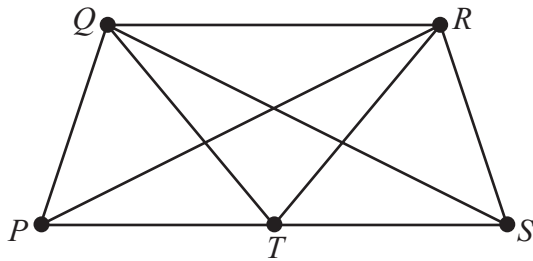

If Roberta starts at point P and walks on each path exactly once, at what point will she finish?

- A. Q
- B. R
- C. S
- D. T

- 13 Which of the following shows the expression below in factored form?

$$x^2 + 2x - 8$$

- A. $(x - 2)(x + 4)$
- B. $(x + 2)(x - 4)$
- C. $(x - 1)(x + 8)$
- D. $(x + 1)(x - 8)$

- 14 What is the value of the expression below?

$$5|4 - 6| - (-3)$$

- A. -13
- B. -7
- C. 13
- D. 17

Question 15 is a short-answer question. Write your answer to this question in the box provided in your Student Answer Booklet. Do not write your answer in this test booklet. You may do your figuring in the test booklet.

- 15 A “wheat penny” is a United States penny that has a picture of wheat on one side. These pennies were only produced from 1909 through 1958.

The members of a coin-collecting group counted the number of wheat pennies in each of their collections. The line plot below shows the number of wheat pennies in each member’s coin collection.

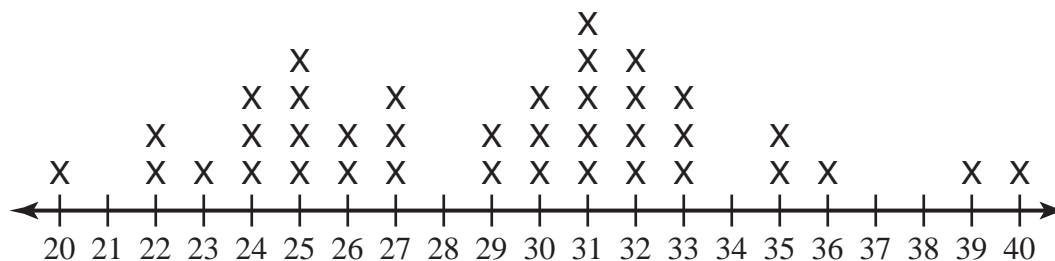

Number of Wheat Pennies in Each Member’s Coin Collection

What is the mode of the data in the line plot?

Question 16 is a short-answer question. Write your answer to this question in the box provided in your Student Answer Booklet. Do not write your answer in this test booklet. You may do your figuring in the test booklet.

16 Dan made an accurate scale drawing of the front of a building.

- The width of the building in Dan's scale drawing is 5 inches.
- The height of the building in his scale drawing is 3 inches.

If the actual width of the building is 100 feet, what is the actual height, in feet, of the building?

Question 17 is an open-response question.

- **BE SURE TO ANSWER AND LABEL ALL PARTS OF THE QUESTION.**
- **Show all your work (diagrams, tables, or computations) in your Student Answer Booklet.**
- **If you do the work in your head, explain in writing how you did the work.**

Write your answer to question 17 in the space provided in your Student Answer Booklet.

17 Rodney is starting a horse-grooming business.

- His initial expense will be a one-time cost of \$200 for equipment.
- His earnings will be \$40 per horse groomed.

Rodney's profit will be equal to his earnings for all horses groomed minus his initial expense.

- What will be Rodney's profit if 15 horses are groomed? Show or explain how you got your answer.
- On the grid in your Student Answer Booklet, plot eight points with coordinates (x, y) , in which x and y are defined as follows:
 - x = the number of horses groomed (in whole numbers from 0 through 7)
 - y = Rodney's profit, in dollars, if x horses are groomedBe sure to label the x -axis and y -axis, indicate the scale on each axis, and include a title for your graph.
- Write an equation of the line that contains all of the points you plotted in part (b). Show or explain how you determined your equation.
- What is the **x -intercept** of the line represented by your equation in part (c)? Show or explain how you got your answer.
- Explain the meaning of the x -intercept you determined in part (d) in terms of the context of this problem.

Questions 18 and 19 are short-answer questions. Write your answers to these questions in the boxes provided in your Student Answer Booklet. Do not write your answers in this test booklet. You may do your figuring in the test booklet.

- 18 Hannah's garden is in the shape of a parallelogram. A diagram representing her garden is shown below.

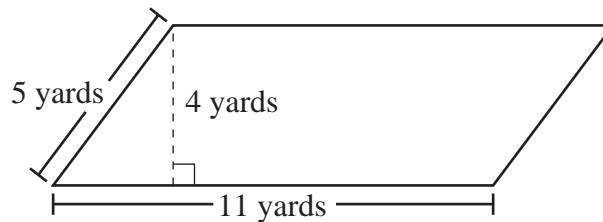

Hannah needs to know the area of the garden in order to buy the correct amount of fertilizer. Based on the dimensions in the diagram, what is the area, in square yards, of Hannah's garden?

- 19 Angelo placed 5 CDs into his CD player. There are 12 songs on each CD.

Angelo set his CD player to select songs in a random order. What is the probability that the first song the CD player selects will be the 4th song on the 3rd CD?

Questions 20 and 21 are open-response questions.

- **BE SURE TO ANSWER AND LABEL ALL PARTS OF EACH QUESTION.**
- **Show all your work (diagrams, tables, or computations) in your Student Answer Booklet.**
- **If you do the work in your head, explain in writing how you did the work.**

Write your answer to question 20 in the space provided in your Student Answer Booklet.

20 Liam and Tobet are going to walk in a fund-raising event to raise money for their school.

- Liam's mother promised to donate to the school \$4 per mile that Liam walks, plus an additional \$30.
 - Tobet's father promised to donate to the school \$6 per mile that Tobet walks, plus an additional \$20.
- a. If Liam walks 15 miles during the event, what is the total amount of money his mother will donate? Show or explain how you got your answer.
 - b. Write an equation that represents y , the total amount of money Liam's mother will donate if Liam walks x miles during the event.
 - c. Write an equation that represents y , the total amount of money Tobet's father will donate if Tobet walks x miles during the event.

After the event, Liam and Tobet compared their results. Liam had walked the same number of miles as Tobet. Liam's mother had donated the same amount of money as Tobet's father.

- d. Using your two equations from parts (b) and (c), determine the number of miles Liam and Tobet each walked during the event. Show or explain how you got your answer.
- e. Using your answer from part (d), determine the total amount of money Liam's mother and Tobet's father **each** donated. Show or explain how you got your answer.

Write your answer to question 21 in the space provided in your Student Answer Booklet.

- 21 The distance, d , in feet, that a dropped rock falls in t seconds can be estimated using the formula below.

$$d = 16t^2$$

Use the formula to answer the following questions.

- What is the distance, in feet, that a dropped rock will fall in 10 seconds? Show your work.
- What is the ratio of the **distance** a dropped rock will fall in 30 seconds as compared to the **distance** a dropped rock will fall in 10 seconds? Show your work.
- How many seconds will it take a dropped rock to fall 144 feet? Show your work.
- To the nearest tenth of a second, how many seconds will it take a dropped rock to fall 80 feet? Show your work.

Mathematics

SESSION 2

*You may use your reference sheet during this session.
You may use a calculator during this session.*



DIRECTIONS

This session contains eighteen multiple-choice questions and three open-response questions. Mark your answers to these questions in the spaces provided in your Student Answer Booklet.

- 22 Which of the following is closest to the circumference, in inches, of a circle that has a diameter of 12 inches?

- A. 18.84
- B. 37.68
- C. 75.36
- D. 113.04

- 23 The table below shows the numbers of days Mallory and her friends went skating last month.

**Numbers of Days
of Skating**

Name	Number of Days
Angela	12
Chelsea	7
Latifa	11
Mallory	12

What are the mean and median for this set of data?

- A. mean = 10.5; median = 11.5
- B. mean = 10.5; median = 9
- C. mean = 12; median = 11.5
- D. mean = 12; median = 9

- 24 A trapezoid and its dimensions are shown below.

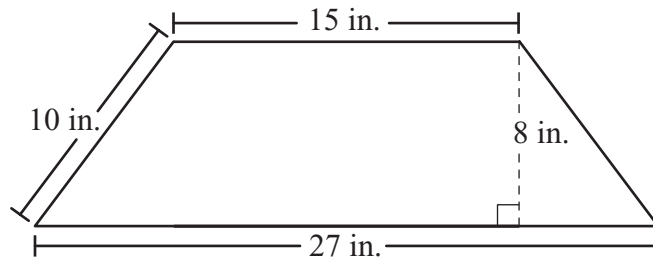

What is the area of the trapezoid?

- A. 60 sq. in.
B. 168 sq. in.
C. 210 sq. in.
D. 336 sq. in.
-
- 25 Julia spent 3 hours hiking 6 miles up a hill. She spent 2 hours hiking 8 miles down the hill on a different path. For Julia's completed hike up and down the hill, what was her average speed, in miles per hour?

- A. 2.0
B. 2.5
C. 2.8
D. 3.0

- 26 A total of 100 people bought all of the tickets that were available for a school raffle.

The frequency table below shows the number of people who bought each number of tickets listed. For example, 27 people bought 2 tickets each.

Number of People Buying Raffle Tickets

Number of Tickets Bought	1	2	3	4	6
Number of People	38	27	20	9	6

For these 100 people, what was the mean number of tickets bought per person?

- A. 1.24
- B. 2.24
- C. 2.50
- D. 3.20

- 27 An equilateral triangle and its side lengths are shown below.

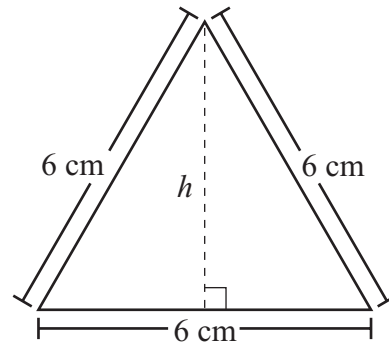

What is h , the height of the equilateral triangle?

- A. 3 cm
- B. 4 cm
- C. $3\sqrt{3}$ cm
- D. $3\sqrt{5}$ cm

- 28 Two containers in the shape of right circular cylinders are equal in height. The radius of the larger container is 3 times the radius of the smaller container.

The volume of the larger container is how many times the volume of the smaller container?

- A. 3
- B. 6
- C. 9
- D. 27

- 29 Triangle XYZ and two angle measures are shown in the diagram below.

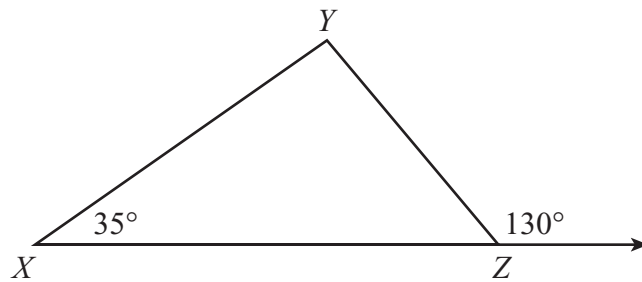

What is the measure of $\angle Y$?

- 30 The length of a rectangle is 1 inch more than 2 times its width. The area of the rectangle is 36 square inches.
- What is the **length** of the rectangle?
- A. 4 inches
 - B. 6 inches
 - C. 9 inches
 - D. 18 inches

Question 31 is an open-response question.

- **BE SURE TO ANSWER AND LABEL ALL PARTS OF THE QUESTION.**
- **Show all your work (diagrams, tables, or computations) in your Student Answer Booklet.**
- **If you do the work in your head, explain in writing how you did the work.**

Write your answer to question 31 in the space provided in your Student Answer Booklet.

- 31** The table below shows the attendance at each of Eagle High School's home football games last season.

**Attendance at
Home Football Games**

Game	Attendance
1st	287
2nd	268
3rd	283
4th	283
5th	270
6th	70
7th	283
8th	275

- a. What is the range of the attendance for the 8 home football games last season? Show or explain how you got your answer.
- b. Determine each of the following measures of the attendance for the 8 games.
- mean
 - median
 - mode

Show or explain how you got each of your answers.

- c. If the attendance at the 6th game is not included in the data set, which measure (mean, median, or mode) has the **greatest** increase in value when compared to your answers in part (b)? Show or explain how you got your answer.

Mark your answers to multiple-choice questions 32 through 40 in the spaces provided in your Student Answer Booklet. Do not write your answers in this test booklet. You may do your figuring in the test booklet.

32 Niraj went on the following airplane flight:

- The flight was 5 hours long.
- The total distance of the flight was 640 miles.
- For the **first** part of the flight, the average speed of the airplane was 140 miles per hour.
- For the **second** part of the flight, the average speed of the airplane was 120 miles per hour.

Which of the following systems of equations can be used to find x , the number of hours in the first part of the flight, and y , the number of hours in the second part of the flight?

A. $x + y = 5$
 $120x + 140y = 640$

B. $x + y = 640$
 $120x + 140y = 5$

C. $x + y = 5$
 $140x + 120y = 640$

D. $x + y = 640$
 $140x + 120y = 5$

- 33 The girls' soccer coach scheduled practice for 10 days during soccer season. The table below shows the number of players who attended practice each day.

**Practice Attendance
Each Day**

Day	Number of Players
1	12
2	13
3	16
4	10
5	9
6	12
7	14
8	12
9	15
10	16

What is the range of the number of players who attended practice over the 10 days?

- A. 4
- B. 7
- C. 9
- D. 16

- 34 An artist carved a sphere out of stone. The radius of the sphere is 0.93 meter. Which of the following is closest to the volume of the sphere?

- A. 3.37 m^3
- B. 3.62 m^3
- C. 10.11 m^3
- D. 11.69 m^3

- 35 Justin drew the bar graph below to represent the time he allocated for each activity during one school day last week.

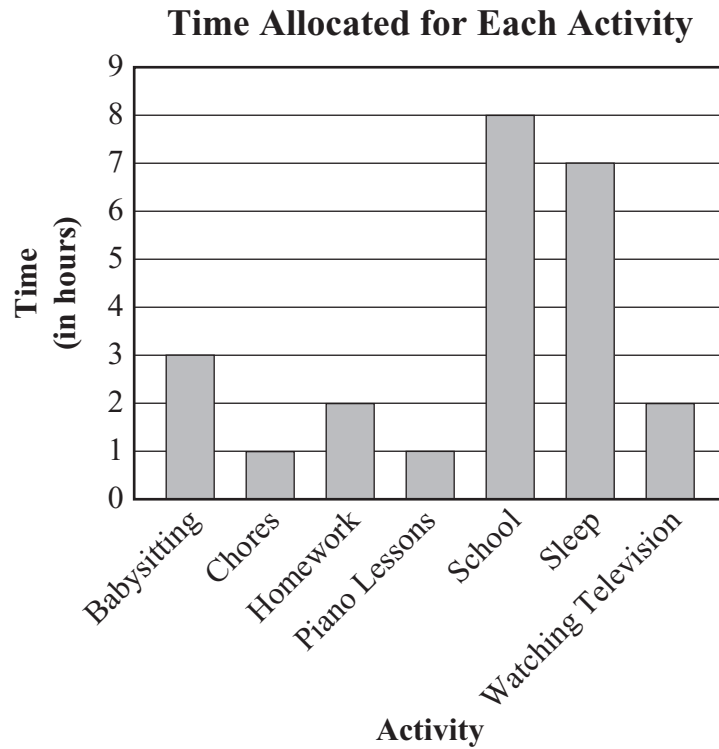

Based on the data in the graph, which of the following best represents the ratio of the time Justin allocated for homework to the time he allocated for school?

- A. $\frac{1}{4}$
- B. $\frac{5}{12}$
- C. 4
- D. 10

- 36 The lines in the diagram below represent four streets in Linda’s hometown.

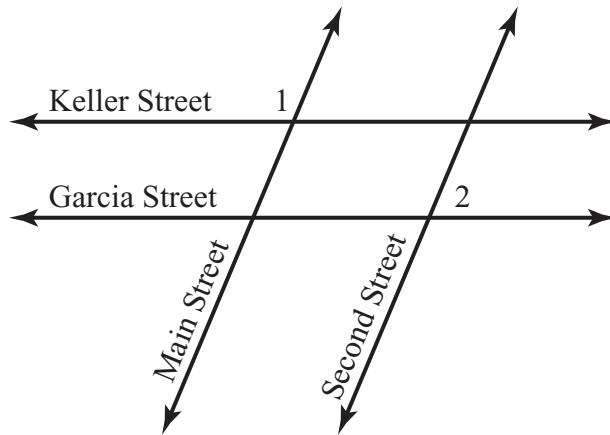

Keller Street is parallel to Garcia Street, and Main Street is parallel to Second Street.

If $m\angle 1 = 95^\circ$, what is $m\angle 2$?

- A. 75°
- B. 85°
- C. 95°
- D. 105°

37 Which of the following describes the slope of a horizontal line on the coordinate plane?

- A. zero
- B. positive
- C. negative
- D. undefined

38 Parallelogram $PQRS$ is shown below.

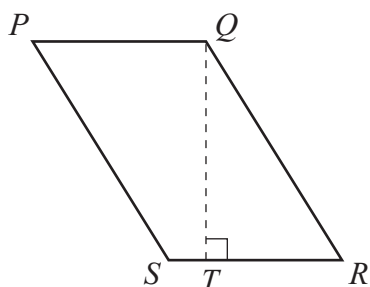

Some of the dimensions of the parallelogram are as follows:

- $QR = 7$ cm
- $RS = 5$ cm
- $QT = 6.5$ cm

What is the area of the parallelogram?

- A. 24 cm^2
- B. 32.5 cm^2
- C. 35 cm^2
- D. 45.5 cm^2

39 Which of the following is the solution to the inequality below?

$$-4x - 7 < 5$$

- A. $x > -\frac{1}{2}$
- B. $x < -\frac{1}{2}$
- C. $x > -3$
- D. $x < -3$

40 Leroy will arrive at Gary's house at a time between 2 p.m. and 4 p.m. this afternoon. At 2 p.m., Gary will begin to watch a two-hour television program. There are 15 minutes of commercials scheduled to be shown during **each** hour of the program.

Assuming that Leroy's arrival time at Gary's house will be random, what is the probability that Leroy will arrive during a commercial?

- A. $\frac{1}{3}$
- B. $\frac{1}{4}$
- C. $\frac{1}{8}$
- D. $\frac{1}{16}$

Questions 41 and 42 are open-response questions.

- **BE SURE TO ANSWER AND LABEL ALL PARTS OF EACH QUESTION.**
- **Show all your work (diagrams, tables, or computations) in your Student Answer Booklet.**
- **If you do the work in your head, explain in writing how you did the work.**

Write your answer to question 41 in the space provided in your Student Answer Booklet.

- 41 Zachary made a right square pyramid out of plaster for an art project. Each side of his pyramid's base measured 8 inches. The slant height, ℓ , of his pyramid measured 5 inches. A diagram of his pyramid is shown below.

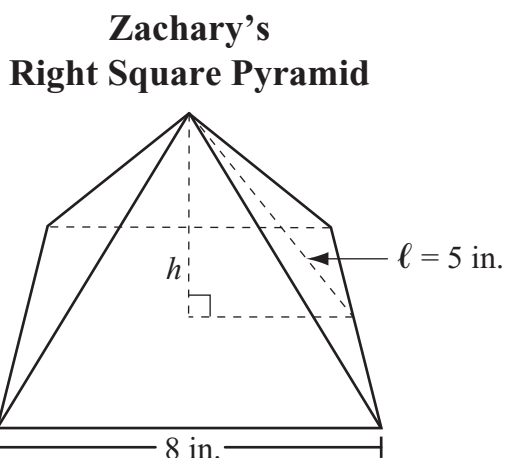

- What is the area, in square inches, of the base of Zachary's pyramid? Show your work.
- What is the total surface area, in square inches, of Zachary's pyramid? Show your work.
- What is h , the height, in inches, of Zachary's pyramid? Show or explain how you got your answer.
- Using the height you determined in part (c), what is the volume, in cubic inches, of Zachary's pyramid? Show your work.

Write your answer to question 42 in the space provided in your Student Answer Booklet.

- 42 A diagram of part of a baseball field and some of its dimensions are shown below. Point F represents First Base, point S represents Second Base, point T represents Third Base, point H represents Home Plate, and point P represents another location on the baseball field.

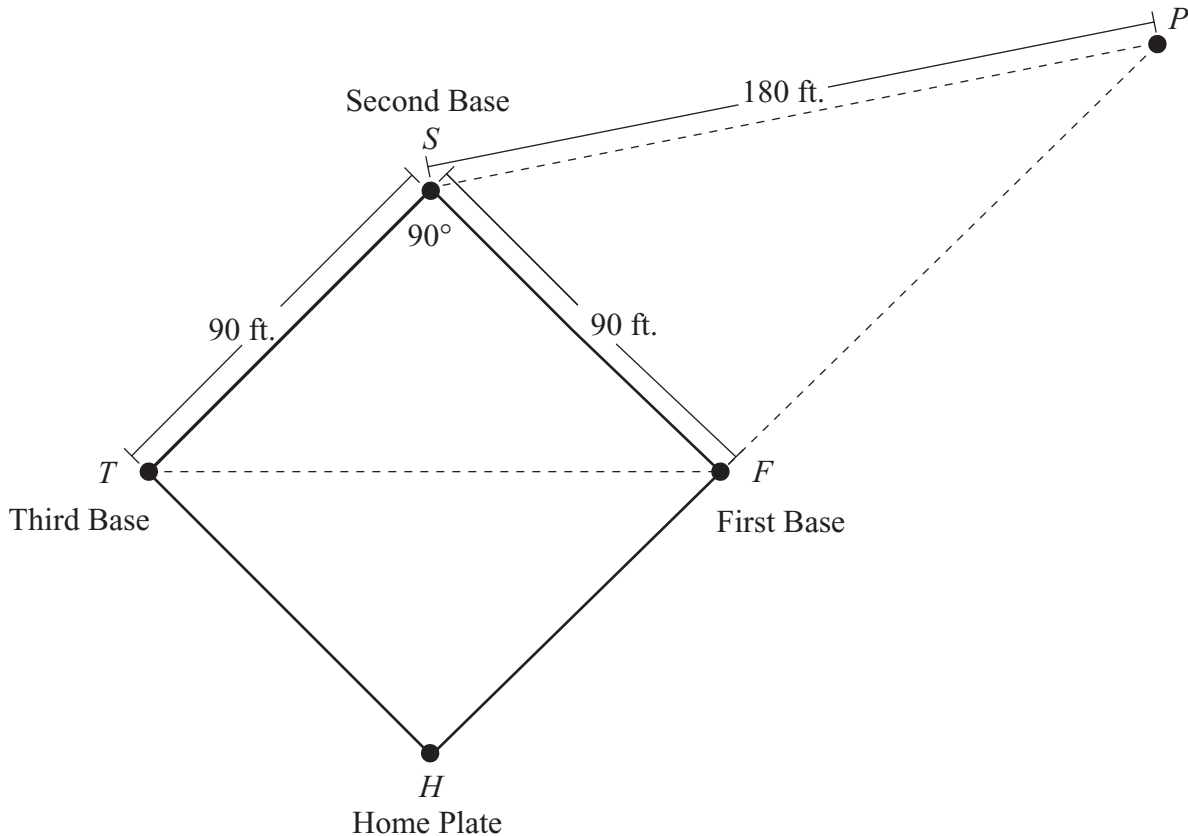

The diagram has the following characteristics:

- Quadrilateral $FSTH$ is a square.
 - Point F lies on \overline{HP} .
 - Triangle FST is isosceles.
- a. What is the measure, in degrees, of $\angle TFS$? Show or explain how you got your answer.
 - b. What is the distance, in feet, between F and T ? Show or explain how you got your answer.

A player caught a ball at point P .

- c. What is the measure, in degrees, of $\angle P$? Show or explain how you got your answer.
- d. What is the length, in feet, of \overline{FP} ? Show or explain how you got your answer.



Massachusetts Comprehensive Assessment System Grade 10 Mathematics Reference Sheet

AREA FORMULAS

- square $A = s^2$
- rectangle $A = bh$
- parallelogram $A = bh$
- triangle $A = \frac{1}{2}bh$
- trapezoid $A = \frac{1}{2}h(b_1 + b_2)$
- circle $A = \pi r^2$

LATERAL SURFACE AREA FORMULAS

- right rectangular prism $LA = 2(hw) + 2(lh)$
- right circular cylinder $LA = 2\pi rh$
- right circular cone $LA = \pi r\ell$
(ℓ = slant height)
- right square pyramid $LA = 2s\ell$
(ℓ = slant height)

TOTAL SURFACE AREA FORMULAS

- cube $SA = 6s^2$
- right rectangular prism $SA = 2(lw) + 2(hw) + 2(lh)$
- sphere $SA = 4\pi r^2$
- right circular cylinder $SA = 2\pi r^2 + 2\pi rh$
- right circular cone $SA = \pi r^2 + \pi r\ell$
(ℓ = slant height)
- right square pyramid $SA = s^2 + 2s\ell$
(ℓ = slant height)

VOLUME FORMULAS

- cube $V = s^3$
(s = length of an edge)
- right rectangular prism $V = lwh$
- OR
- $V = Bh$
(B = area of a base)
- sphere $V = \frac{4}{3}\pi r^3$
- right circular cylinder $V = \pi r^2 h$
- right circular cone $V = \frac{1}{3}\pi r^2 h$
- right square pyramid $V = \frac{1}{3}s^2 h$

CIRCLE FORMULAS

- $C = 2\pi r$
- $A = \pi r^2$

SPECIAL RIGHT TRIANGLES

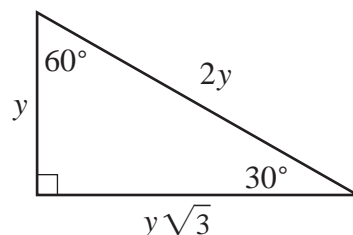
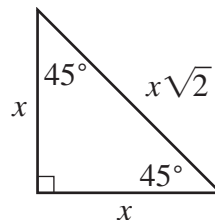

Grade 10 Mathematics
Spring 2007 Released Items:
Reporting Categories, Standards, and Correct Answers

Item No.	Page No.	Reporting Category	Standard	Correct Answer (MC/SA)*
1	381	<i>Number Sense and Operations</i>	10.N.2	A
2	381	<i>Number Sense and Operations</i>	10.N.3	B
3	382	<i>Data Analysis, Statistics, and Probability</i>	10.D.1	A
4	382	<i>Patterns, Relations, and Algebra</i>	10.P.3	D
5	382	<i>Number Sense and Operations</i>	10.N.2	C
6	383	<i>Patterns, Relations, and Algebra</i>	10.P.1	C
7	383	<i>Number Sense and Operations</i>	8.N.2	B
8	383	<i>Patterns, Relations, and Algebra</i>	10.P.3	B
9	383	<i>Number Sense and Operations</i>	10.N.3	A
10	384	<i>Data Analysis, Statistics, and Probability</i>	10.D.2	B
11	385	<i>Patterns, Relations, and Algebra</i>	10.P.5	C
12	385	<i>Geometry</i>	10.G.11	C
13	385	<i>Patterns, Relations, and Algebra</i>	10.P.4	A
14	385	<i>Number Sense and Operations</i>	10.N.2	C
15	386	<i>Data Analysis, Statistics, and Probability</i>	10.D.1	31
16	387	<i>Geometry</i>	10.G.4	60 feet
17	388	<i>Patterns, Relations, and Algebra</i>	10.P.2	
18	389	<i>Measurement</i>	10.M.1	44 square yards
19	389	<i>Data Analysis, Statistics, and Probability</i>	8.D.4	$\frac{1}{60}$ or equivalent
20	390	<i>Patterns, Relations, and Algebra</i>	10.P.8	
21	391	<i>Number Sense and Operations</i>	10.N.2	
22	392	<i>Measurement</i>	10.M.1	B
23	392	<i>Data Analysis, Statistics, and Probability</i>	10.D.1	A
24	393	<i>Measurement</i>	10.M.1	B
25	393	<i>Patterns, Relations, and Algebra</i>	10.P.7	C
26	394	<i>Data Analysis, Statistics, and Probability</i>	10.D.1	B
27	394	<i>Geometry</i>	10.G.6	C
28	394	<i>Measurement</i>	10.M.3	C
29	395	<i>Geometry</i>	10.G.5	D
30	395	<i>Patterns, Relations, and Algebra</i>	10.P.7	C
31	396	<i>Data Analysis, Statistics, and Probability</i>	10.D.1	
32	397	<i>Patterns, Relations, and Algebra</i>	10.P.8	C
33	398	<i>Data Analysis, Statistics, and Probability</i>	10.D.1	B
34	398	<i>Measurement</i>	10.M.2	A
35	399	<i>Data Analysis, Statistics, and Probability</i>	10.D.1	A
36	400	<i>Geometry</i>	10.G.3	B
37	401	<i>Patterns, Relations, and Algebra</i>	10.P.2	A
38	401	<i>Measurement</i>	10.M.1	B
39	401	<i>Patterns, Relations, and Algebra</i>	10.P.6	C
40	401	<i>Data Analysis, Statistics, and Probability</i>	8.D.4	B
41	402	<i>Measurement</i>	10.M.2	
42	403	<i>Geometry</i>	10.G.6	

* Answers are provided here for multiple-choice items and short-answer items only. Sample responses and scoring guidelines for open-response items, which are indicated by shaded cells, will be posted to the Department's Web site later this year.

XVI. Science and Technology/Engineering,
Grade 5

Grade 5 Science and Technology/Engineering Test

The spring 2007 grade 5 MCAS Science and Technology/Engineering test was based on learning standards in the Massachusetts *Science and Technology/Engineering Curriculum Framework* (2006). The *Framework* identifies four major content strands, listed below. Page numbers for the grades 3–5 learning standards appear in parentheses.

- Earth and Space Science (*Framework*, pages 26–29)
- Life Science (Biology) (*Framework*, pages 46–49)
- Physical Sciences (Chemistry and Physics) (*Framework*, pages 64–66)
- Technology/Engineering (*Framework*, page 86)

The *Science and Technology/Engineering Curriculum Framework* is available on the Department Web site at www.doe.mass.edu/frameworks/current.html.

In *Test Item Analysis Reports* and on the Subject Area Subscore pages of the *MCAS School Reports* and *District Reports*, Science and Technology/Engineering test results are reported under four MCAS reporting categories, which are identical to the four *Curriculum Framework* content strands listed above.

Test Sessions

The MCAS grade 5 Science and Technology/Engineering test included two separate test sessions. Each session included multiple-choice and open-response questions.

Reference Materials and Tools

The use of bilingual word-to-word dictionaries was allowed for current and former limited English proficient students only, during both Science and Technology/Engineering test sessions. No other reference tools or materials were allowed.

Cross-Reference Information

The table at the conclusion of this chapter indicates each item’s reporting category and the *Framework* learning standard it assesses. The correct answers for multiple-choice questions are also displayed in the table.

Science and Technology/Engineering

SESSION 1

DIRECTIONS

This session contains seventeen multiple-choice questions and two open-response questions. Mark your answers to these questions in the spaces provided in your Student Answer Booklet.

1 Some types of trees are able to survive the heat of a forest fire. Which of the following characteristics would **best** help a tree survive a fire?

- A. large leaves
- B. shallow roots
- C. thick bark
- D. thin trunks

2 The picture below shows an antique piano stool.

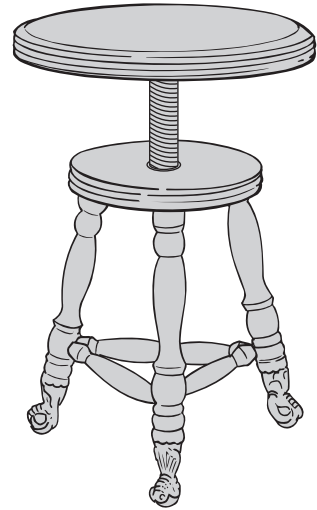

This piano stool uses what type of simple machine to adjust the height?

- A. wedge
- B. screw
- C. pulley
- D. lever

3 Which diagram below shows a circuit that will cause the bulb to light?

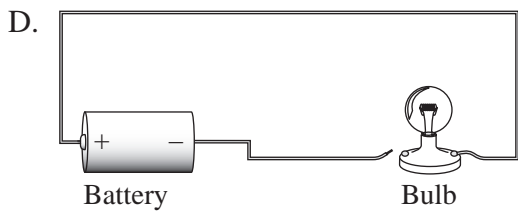
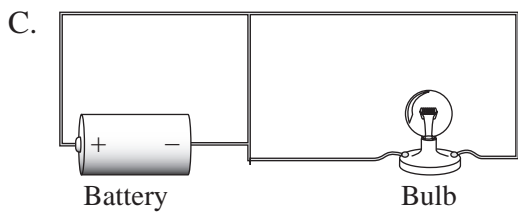
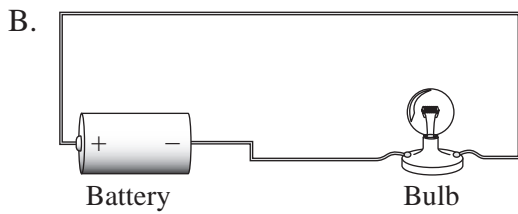
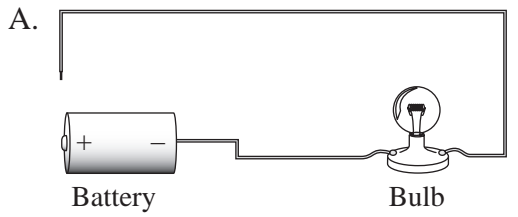

4 The picture below shows a frozen juice bar.

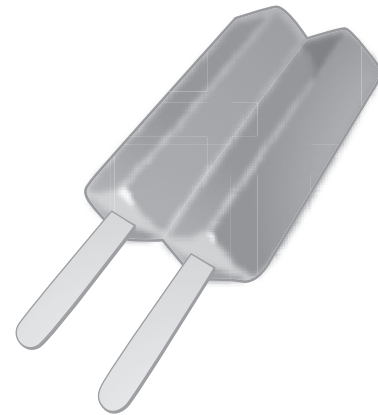

The frozen juice bar was placed in a bowl and left to melt. Which of the following properties of the juice bar changed the **most** once it melted?

- A. color
- B. mass
- C. shape
- D. volume

5 The Mohs scale for minerals is shown below.

softest → hardest									
1	2	3	4	5	6	7	8	9	10
talc	gypsum	calcite	fluorite	apatite	feldspar	quartz	topaz	corundum	diamond

An unknown mineral can be scratched by topaz, but not by feldspar. According to the Mohs scale, which of the following **best** describes the hardness of the unknown mineral?



- A. less than 5
- B. more than 8
- C. less than 8, but more than 6
- D. more than 4, but less than 6

6 Tom needs to buy some screws to use with a certain type of screwdriver. When he reads the boxes at the store, which of the following sets of information would **most** help Tom choose the correct type of screw?

A.

	Composition
Screw Type 1	steel
Screw Type 2	stainless steel



B.

Screw Type 1	
Screw Type 2	

C.

	Number of Screws per Pound
Screw Type 1	165
Screw Type 2	150

D.

Screw Type 1	
Screw Type 2	

7 Each year, humpback whales migrate from the coast of Antarctica to the north coast of Australia. The map below shows the whales' migration route.



Which of the following are the whales **most likely** responding to when they begin to migrate?

- A. the force of gravity
- B. a shift in ocean waves
- C. a change in water temperature
- D. the approach of stormy weather

- 8 Delilah put a container of water in the freezer and left it there overnight. The next morning she saw that the water in the container had changed to ice.
- Which of the following statements **best** explains why the water changed to ice?
- A. The water gained energy.
 - B. The water absorbed light.
 - C. Mass was released from the water.
 - D. Heat was taken away from the water.

- 9 The picture below shows four parts of a wooden pencil.

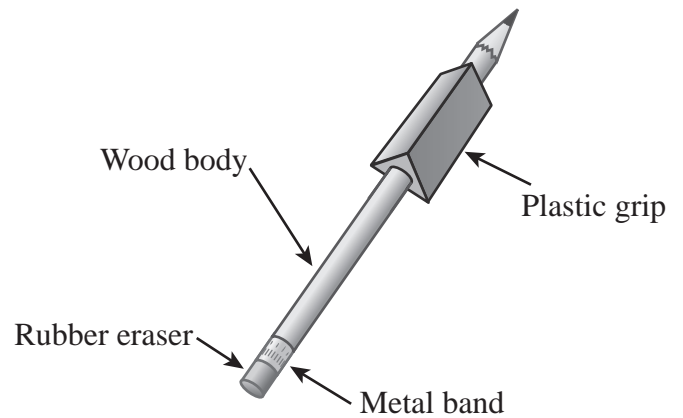

Which part of the pencil is the **best** conductor of electricity?

- A. metal band
- B. plastic grip
- C. rubber eraser
- D. wood body

- 10 Four parts of a sunflower plant are identified by numbers in the picture below.

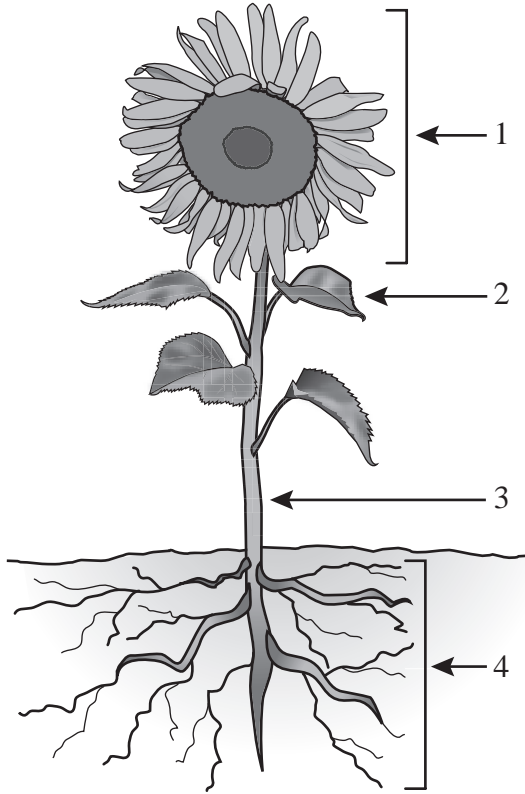

Which numbered part of the sunflower plant is **mainly** responsible for reproduction?

- A. part 1
- B. part 2
- C. part 3
- D. part 4

- 11 Dora wrote down some observations of four rock samples she was studying. Based on her observations, which of the following rock samples is **most likely** a sedimentary rock?

A.

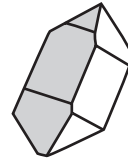

has large crystal shape that is almost clear, has smooth sides

B.



has many very small grains of sand in different layers

C.

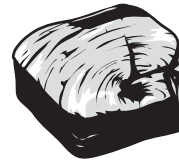

has solid black color, looks like smooth glass with sharp edges

D.

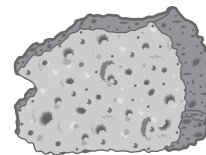

has rough surface full of holes and is light in weight

- 12 Carol poured some water into a 200-milliliter (mL) graduated cylinder. Pictured below are Carol's graduated cylinder and four numbered graduated cylinders.

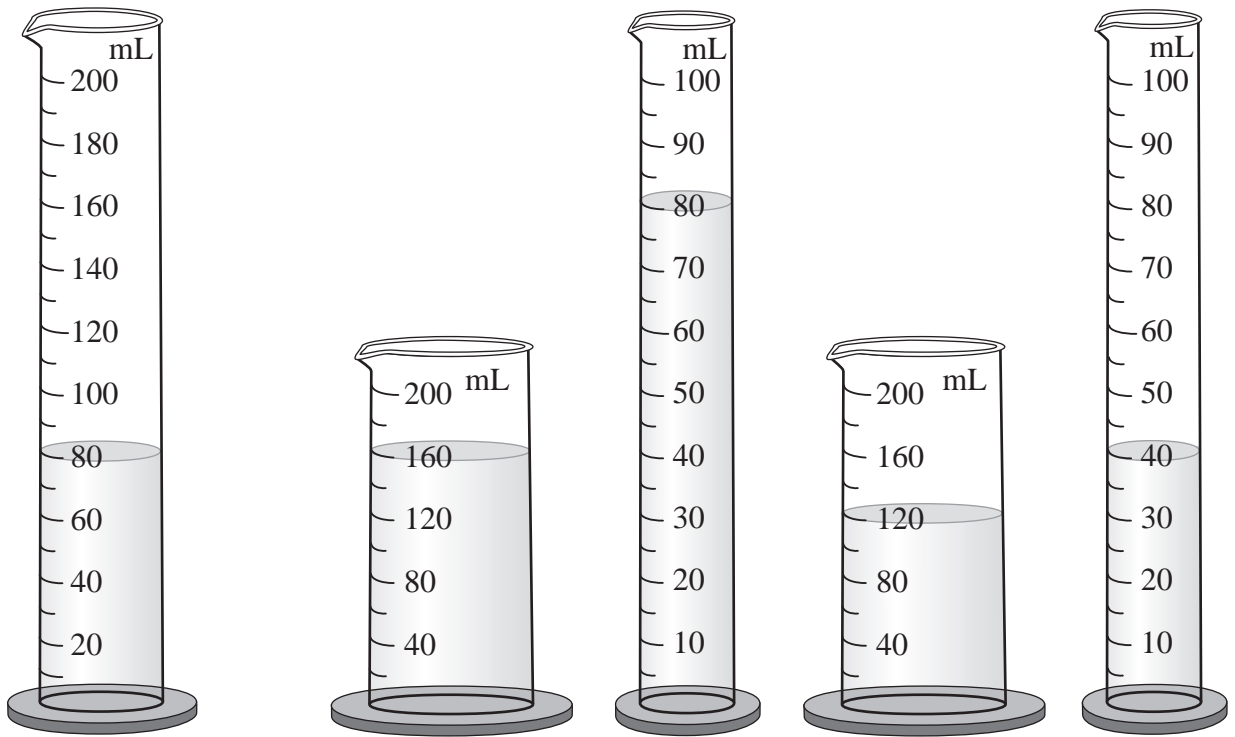

Carol's graduated cylinder

1

2

3

4

Which numbered graduated cylinder contains the same volume of water as Carol's graduated cylinder?

- A. graduated cylinder 1
- B. graduated cylinder 2
- C. graduated cylinder 3
- D. graduated cylinder 4

- 13 While on a walk, Samuel saw a tree he had not seen before. He used a key to help him identify the type of tree. A branch from the tree and the key he used are shown below.

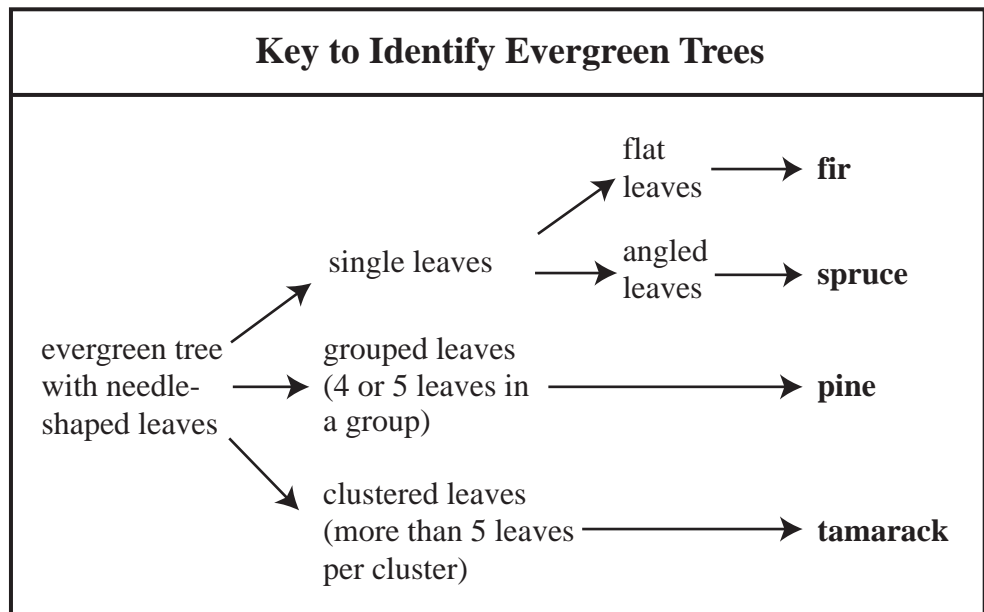
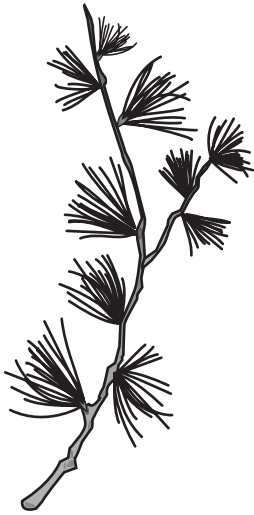

Based on the key, which type of tree did Samuel **most likely** see?

- A. fir
- B. spruce
- C. pine
- D. tamarack

- 14 The picture below shows a volleyball net with the ropes pulled tight.

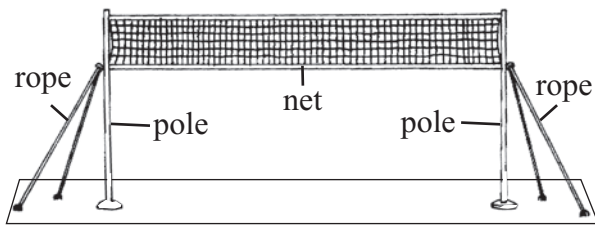

Which of the following properties of the ropes is **most** important for holding the net in place?

- A. flexibility
- B. hardness
- C. strength
- D. weight

- 15 A solar panel is used to collect energy from the Sun and change it into other forms of energy. The picture below shows some solar panels on the roof of a building.

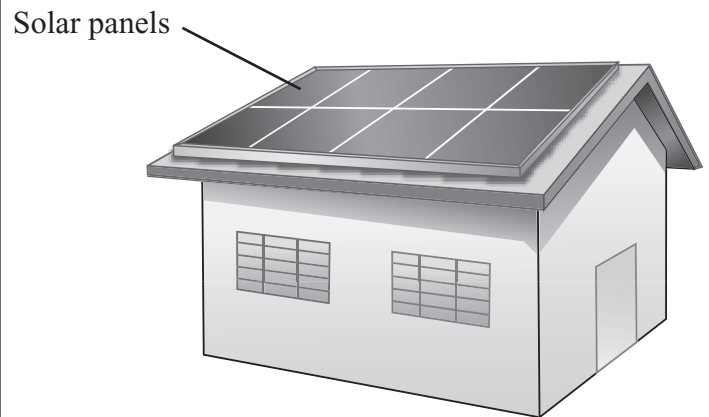

Which form of energy is collected by the solar panels?

- A. wind
- B. sound
- C. magnetic
- D. light

- 16 Andrea has a wooden board that is 3 m long, as shown below.

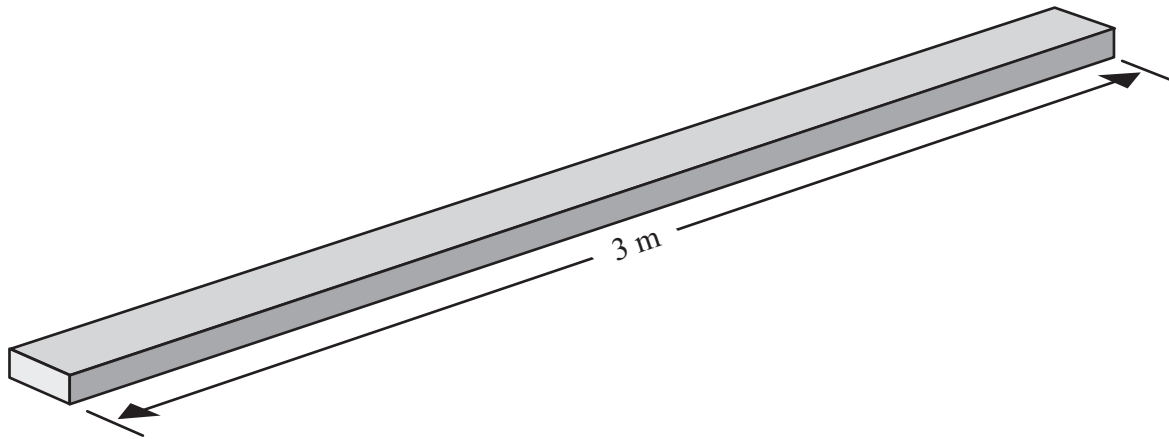

Which of the following pairs of tools would be **best** for Andrea to use to cut the board into three pieces of equal length?

- A. a saw and an ax
- B. an ax and a hammer
- C. a tape measure and a saw
- D. a hammer and a tape measure

- 17 Which of the following has the **greatest** effect on the ability of soil to hold water?
- A. the age of the soil particles
 - B. the size of the soil particles
 - C. the color of the soil particles
 - D. the luster of the soil particles

Questions 18 and 19 are open-response questions.

- **BE SURE TO ANSWER AND LABEL ALL PARTS OF EACH QUESTION.**
- **Show all your work (diagrams, tables, or computations) in your Student Answer Booklet.**
- **If you do the work in your head, explain in writing how you did the work.**

Write your answer to question 18 in the space provided in your Student Answer Booklet.

- 18 The surface of Earth is always changing. Some natural processes change Earth’s surface slowly over time and others change Earth’s surface very quickly. The picture below shows an area of Earth’s surface that was shaped by natural processes.



©Royalty-Free/Corbis

Name and describe **three** natural processes that might have helped to shape this area.

Write your answer to question 19 in the space provided in your Student Answer Booklet.

- 19 Rosa wants to measure the depth of the well in her backyard. To help her find the depth of the well, Rosa gathered her tape measure and several objects from around her house. Her tape measure is 12 ft. long, but the well is deeper than 12 ft. The well and the objects that Rosa gathered are shown below.

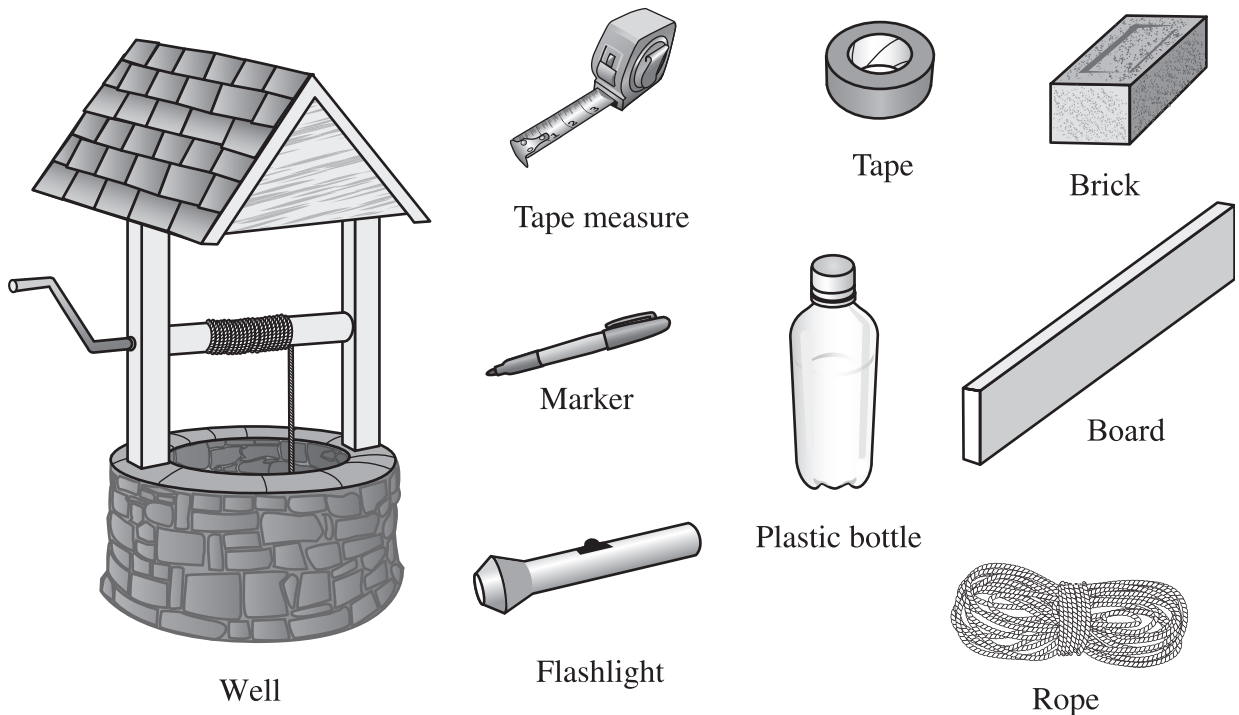

- a. Identify which of these objects Rosa can use with her tape measure to find the depth of the well.
- b. Explain how Rosa can use her tape measure and **each** object you identified in part (a) to find the depth of the well.

Science and Technology/Engineering

SESSION 2

DIRECTIONS

This session contains seventeen multiple-choice questions and three open-response questions. Mark your answers to these questions in the spaces provided in your Student Answer Booklet.

- 20 The picture below shows a plant that is bending as it grows.

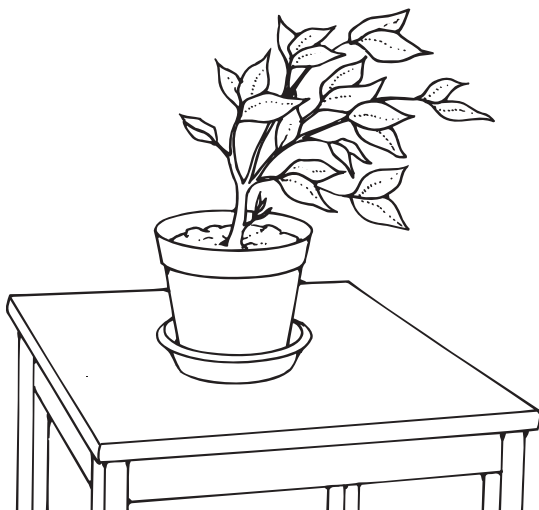

What **most likely** caused the plant to bend this way?

- A. fertilizer
- B. gravity
- C. heat
- D. light

- 21 Which form of precipitation is **most likely** to cause damage when hitting the roof of a car?

- A. hail
- B. rain
- C. sleet
- D. snow

- 22 The picture below shows tongs.

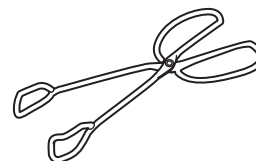

The tongs work as which of the following simple machines?

- A. inclined plane
- B. lever
- C. pulley
- D. wedge

- 23 An incomplete food chain is shown below.

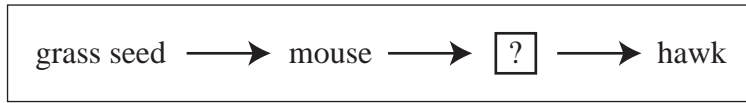

Which of the following organisms would **best** complete the food chain?

- A. rabbit
 - B. robin
 - C. snake
 - D. tree
-
- 24 Steel cans are separated from aluminum cans in a recycling center. Which of the following is the **best** way the recycling center can separate the steel cans from the aluminum cans?
- A. sort the cans by size
 - B. put the cans in water
 - C. cool the cans to a low temperature
 - D. put the cans under an electromagnet

25 Alexa wants to build a machine for her technology class. To think of ideas, she drew four sketches of moving parts for her machine. Which design will work?

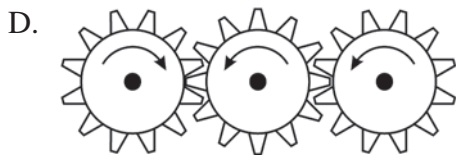
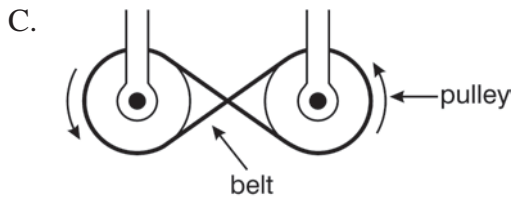
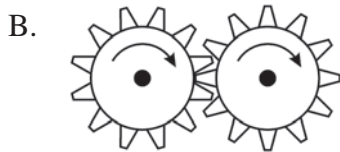
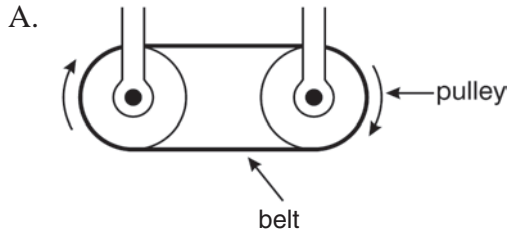

26 Which of the following pictures shows a stage in a frog's life cycle when it breathes entirely through gills?

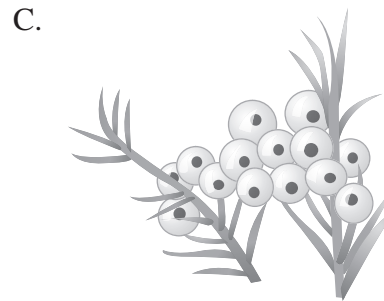
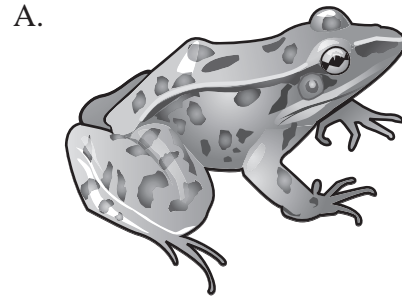

- 27 The picture below shows a musical instrument that Jamie made during science class. Each string on the instrument will produce a different sound when plucked.

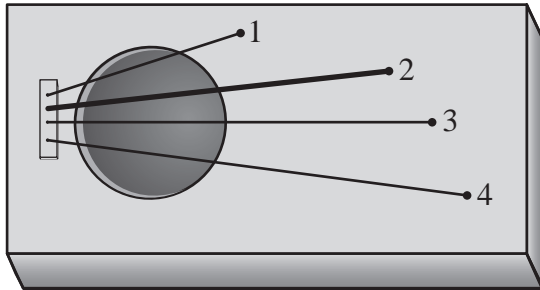

Which of the following identifies the string that will **most likely** produce the sound with the highest pitch?

- A. string 1, because it is the shortest
- B. string 2, because it is the thickest
- C. string 3, because it is centered over the hole
- D. string 4, because it is the longest

- 28 The diagram below represents Earth's orbit around the Sun.

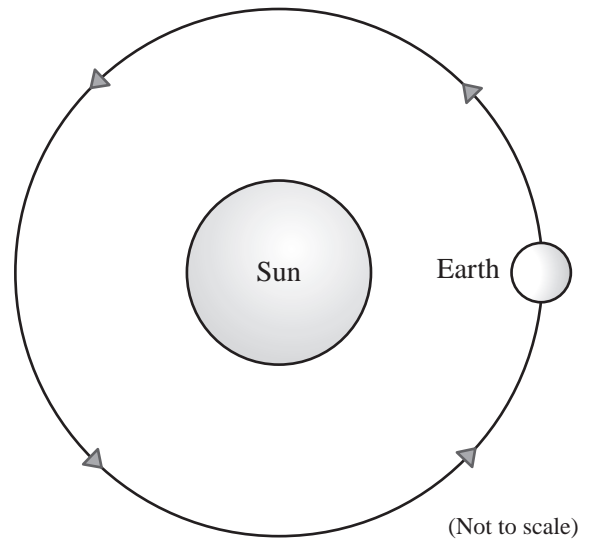

About how long does it take Earth to make one complete orbit around the Sun?

- A. 24 hours
- B. 7 days
- C. 1 month
- D. 1 year

- 29 A crate for carrying milk containers is shown below.

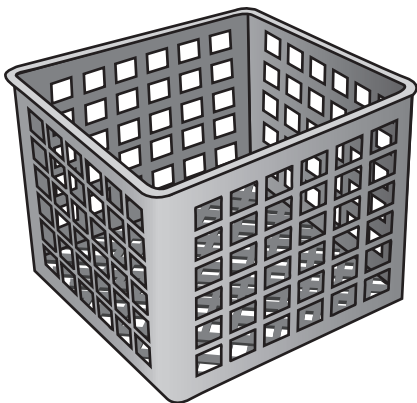

An engineer is designing milk containers to put in the crate. In her design, she wants to fit as many milk containers as possible in each crate.

Which of the following features of the milk containers is **most** important to consider in her design?

- A. color
- B. hardness
- C. shape
- D. weight

- 30 A student places a sheet of black construction paper on her desk. What happens to **most** of the light that strikes the black construction paper?

- A. The light is bent by the paper.
- B. The light reflects off the paper.
- C. The light is absorbed by the paper.
- D. The light passes through the paper.

- 31 Rachel purchased a kit for making a skateboard ramp. Which of the following is **most important** to have for putting the ramp together?

- A. a picture showing the colors of different ramp parts
- B. a diagram showing some ways to use the ramp
- C. a list of prices for other available kits
- D. a set of instructions for the kit materials

32 The map below shows the continental United States and four arrows representing wind directions.

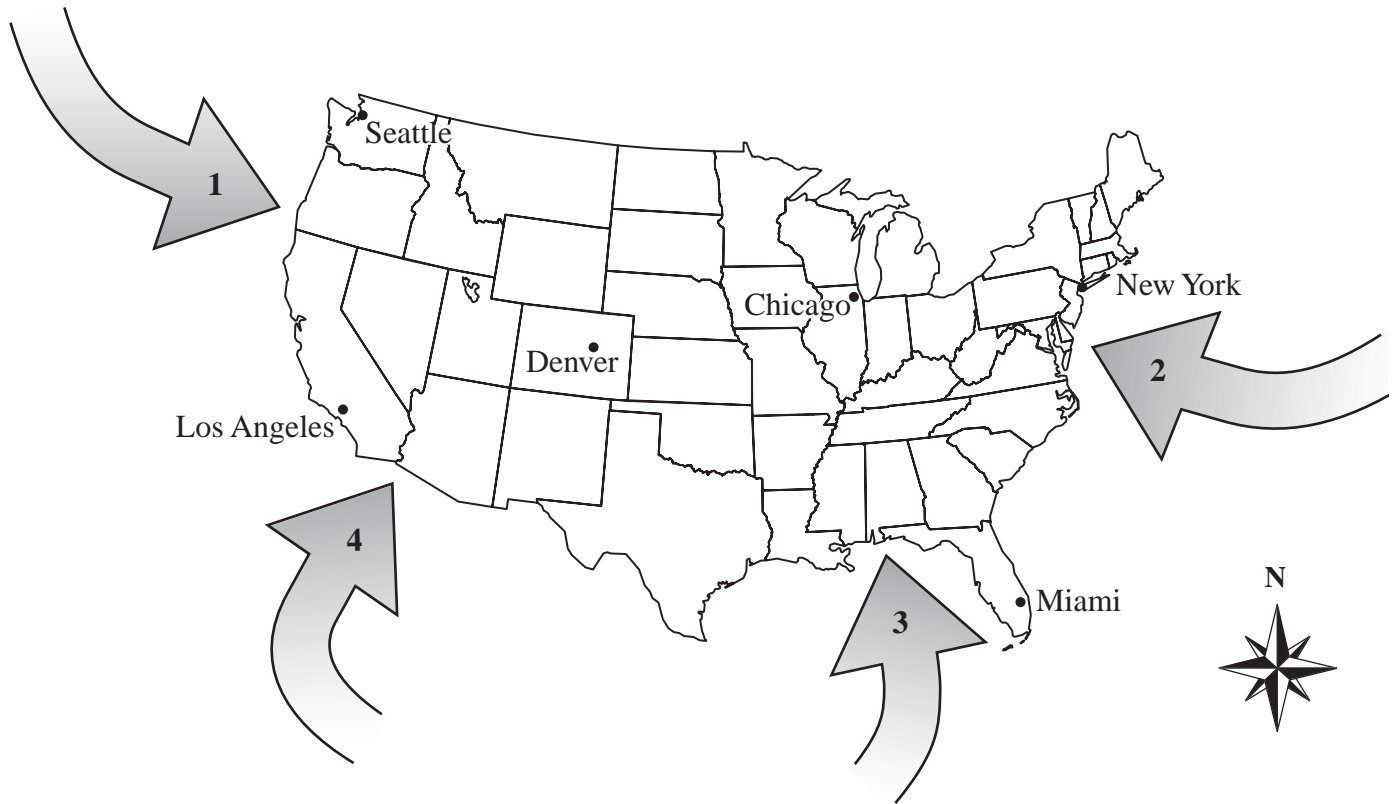

Which arrow **best** represents the direction of the jet stream that influences weather across the continental United States?

- A. arrow 1
- B. arrow 2
- C. arrow 3
- D. arrow 4

33 The picture below shows the foot of a certain species of bird.

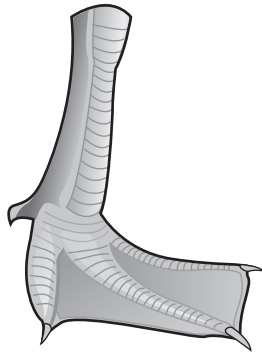

In which of the following environments is this species **best** adapted for survival?

- A. desert
- B. freshwater lake
- C. meadow
- D. tropical rain forest

- 34 Lyle is planning to buy a microwave oven. He will put it in his kitchen in the space labeled in the diagram below.

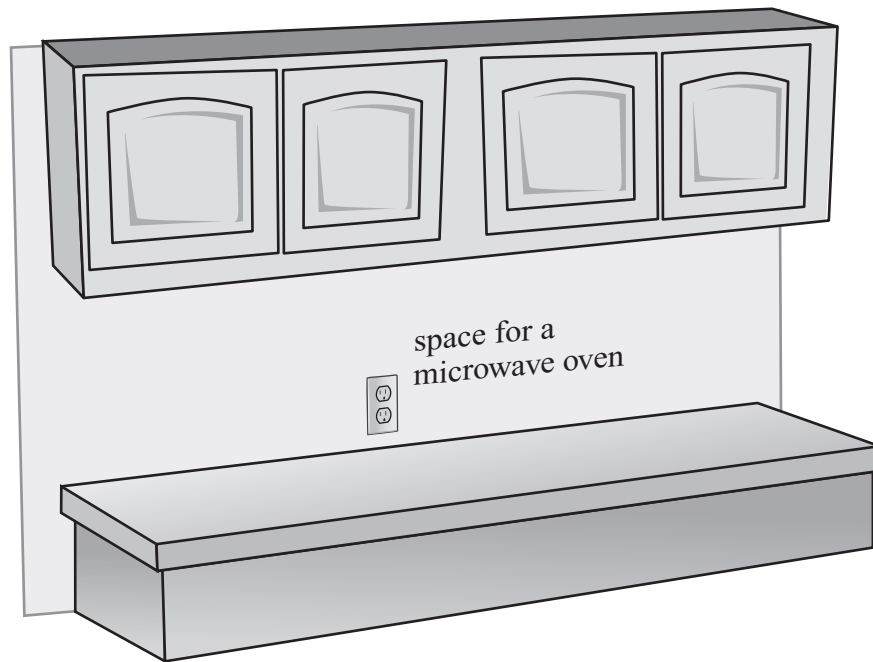

In order to be sure he can put the microwave oven in the space in the kitchen, which of the following questions should Lyle ask before buying the microwave oven?

- A. Is the microwave oven powered by electricity?
- B. Does the microwave oven have an automatic timer?
- C. What are the measurements of the microwave oven?
- D. How many power levels does the microwave oven have?

- 35 Which of the following forms of energy can travel by vibrating particles of air?

- A. electrical
- B. light
- C. magnetic
- D. sound

36 The diagram below names three of the four stages in the life cycle of a butterfly.

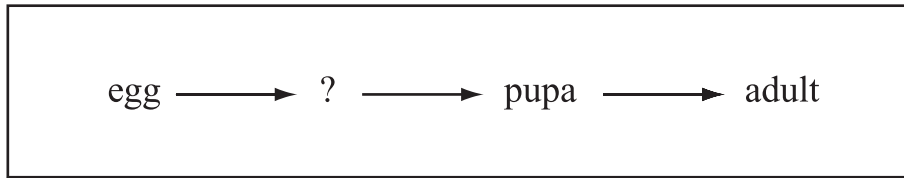

Which of the following pictures shows the stage that is missing in the diagram?

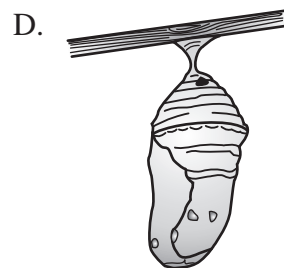
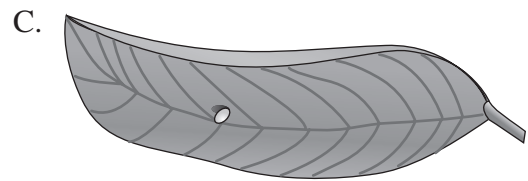
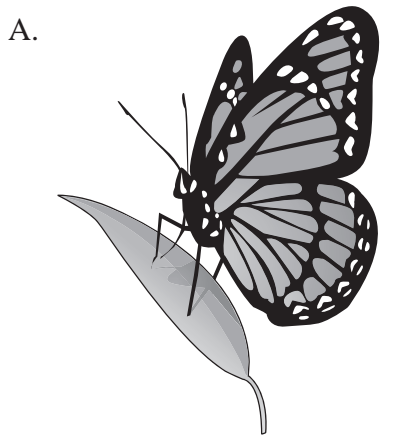

Questions 37 through 39 are open-response questions.

- **BE SURE TO ANSWER AND LABEL ALL PARTS OF EACH QUESTION.**
- **Show all your work (diagrams, tables, or computations) in your Student Answer Booklet.**
- **If you do the work in your head, explain in writing how you did the work.**

Write your answer to question 37 in the space provided in your Student Answer Booklet.

- 37 The pictures below show two cubes that are the same size. One cube is made of iron metal and the other cube is made of pine wood.

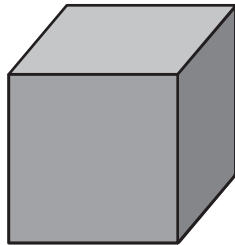

Iron cube

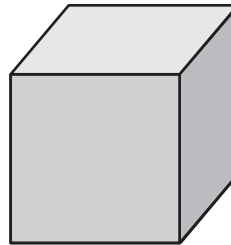

Pine cube

The two cubes can be compared by their physical properties. One physical property is color. The iron cube has a gray color and the pine cube has a tan color.

- a. Name **two** other physical properties that can be used to compare the cubes.
- b. For **each** physical property that you named in part (a), describe how you could measure or test that physical property to compare the cubes.

Write your answer to question 38 in the space provided in your Student Answer Booklet.

- 38 A geology club is planning to go on a trip to the coast to observe rock formations. Based on the club's calendar, they can schedule the trip in either May or September. The table below shows the average weather conditions at the coast for May and September.

Average Weather Conditions at the Coast

Condition	May	September
high temperature (°F)	55	63
number of days with precipitation	12	9
number of days with sunshine	16	22
wind speed (mi. per hr)	14	10

- Which month has the highest average wind speed? Include data from the table to support your answer.
- Based on the information in the table, which month would **most likely** have the best weather conditions for a trip to the coast to observe rock formations? Include data from the table to support your answer.
- When the geology club finally went on their trip to the coast, it was 60°F with cloudy skies, and the wind speed was 5 mi. per hr. Explain why it is not unusual that the weather conditions on the day of the club's trip were different from those shown in the table for either month.

Write your answer to question 39 in the space provided in your Student Answer Booklet.

- 39 During the fall, changes in the environment in Massachusetts cause many animals to prepare for the coming winter season.
- Describe **two** changes in the environment in Massachusetts during the fall that cause animals to prepare for the winter.
 - Identify **one** way that animals in Massachusetts prepare to survive the winter. Explain how this helps the animals to survive the winter.

**Grade 5 Science and Technology/Engineering
Spring 2007 Released Items:
Reporting Categories, Standards, and Correct Answers**

Item No.	Page No.	Reporting Category	Standard	Correct Answer (MC)*
1	409	<i>Life Science (Biology)</i>	2	C
2	409	<i>Technology/Engineering</i>	1.3	B
3	410	<i>Physical Sciences (Chemistry and Physics)</i>	6	B
4	410	<i>Physical Sciences (Chemistry and Physics)</i>	2	C
5	411	<i>Earth and Space Science</i>	2	C
6	412	<i>Technology/Engineering</i>	2.2	B
7	412	<i>Life Science (Biology)</i>	7	C
8	413	<i>Physical Sciences (Chemistry and Physics)</i>	3	D
9	413	<i>Physical Sciences (Chemistry and Physics)</i>	7	A
10	414	<i>Life Science (Biology)</i>	2	A
11	414	<i>Earth and Space Science</i>	3	B
12	415	<i>Physical Sciences (Chemistry and Physics)</i>	2	B
13	416	<i>Life Science (Biology)</i>	1	D
14	417	<i>Technology/Engineering</i>	1.1	C
15	417	<i>Physical Sciences (Chemistry and Physics)</i>	4	D
16	418	<i>Technology/Engineering</i>	1.2	C
17	419	<i>Earth and Space Science</i>	5	B
18	420	<i>Earth and Space Science</i>	12	
19	421	<i>Technology/Engineering</i>	1.2	
20	422	<i>Life Science (Biology)</i>	9	D
21	422	<i>Earth and Space Science</i>	7	A
22	422	<i>Technology/Engineering</i>	1.3	B
23	423	<i>Life Science (Biology)</i>	11	C
24	423	<i>Physical Sciences (Chemistry and Physics)</i>	8	D
25	424	<i>Technology/Engineering</i>	2.3	A
26	424	<i>Life Science (Biology)</i>	4	B
27	425	<i>Physical Sciences (Chemistry and Physics)</i>	11	A
28	425	<i>Earth and Space Science</i>	14	D
29	426	<i>Technology/Engineering</i>	2.3	C
30	426	<i>Physical Sciences (Chemistry and Physics)</i>	12	C
31	426	<i>Technology/Engineering</i>	2.2	D
32	427	<i>Earth and Space Science</i>	8	A
33	428	<i>Life Science (Biology)</i>	6	B
34	429	<i>Technology/Engineering</i>	2.3	C
35	429	<i>Physical Sciences (Chemistry and Physics)</i>	11	D
36	430	<i>Life Science (Biology)</i>	4	B
37	431	<i>Physical Sciences (Chemistry and Physics)</i>	1	
38	432	<i>Earth and Space Science</i>	6	
39	433	<i>Life Science (Biology)</i>	8	

* Answers are provided here for multiple-choice items only. Sample responses and scoring guidelines for open-response items, which are indicated by shaded cells, will be posted to the Department's Web site later this year.

XVII. Science and Technology/Engineering,
Grade 8

Grade 8 Science and Technology/Engineering Test

The spring 2007 grade 8 MCAS Science and Technology/Engineering test was based on learning standards in the Massachusetts *Science and Technology/Engineering Curriculum Framework* (2006). The *Framework* identifies four major content strands listed below. Page numbers for the grades 6–8 learning standards appear in parentheses.

- Earth and Space Science (*Framework*, pages 32–33)
- Life Science (Biology) (*Framework*, pages 51–53)
- Physical Sciences (Chemistry and Physics) (*Framework*, pages 67–68)
- Technology/Engineering (*Framework*, pages 87–89)

The *Science and Technology/Engineering Curriculum Framework* is available on the Department Web site at www.doe.mass.edu/frameworks/current.html.

In *Test Item Analysis Reports* and on the Subject Area Subscore pages of the *MCAS School Reports* and *District Reports*, Science and Technology/Engineering test results are reported under four MCAS reporting categories, which are identical to the four *Curriculum Framework* content strands listed above.

Test Sessions

The MCAS grade 8 Science and Technology/Engineering test included two separate test sessions. Each session included multiple-choice and open-response questions.

Reference Materials and Tools

The use of bilingual word-to-word dictionaries was allowed for current and former limited English proficient students only, during both Science and Technology/Engineering test sessions. No other reference tools or materials were allowed.

Cross-Reference Information

The table at the conclusion of this chapter indicates each item's reporting category and the *Framework* learning standard it assesses. The correct answers for multiple-choice questions are also displayed in the table.

Science and Technology/Engineering

SESSION 1

DIRECTIONS

This session contains seventeen multiple-choice questions and two open-response questions. Mark your answers to these questions in the spaces provided in your Student Answer Booklet.

- 1 Which of the following keeps the planets in our solar system in orbit around the Sun?
- A. atmospheric pressure
 - B. gravitational force
 - C. electromagnetic energy
 - D. thermal energy

- 2 Which of the following groups of organisms uses sunlight to convert carbon dioxide and water into sugar and oxygen?
- A. carnivores
 - B. decomposers
 - C. herbivores
 - D. producers

3 The law of conservation of mass can be demonstrated by a chemical reaction. Which of the following models of a chemical reaction **best** represents the law of conservation of mass?

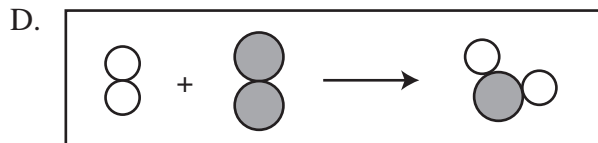
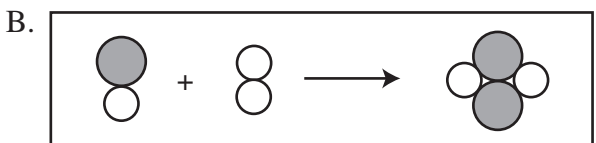
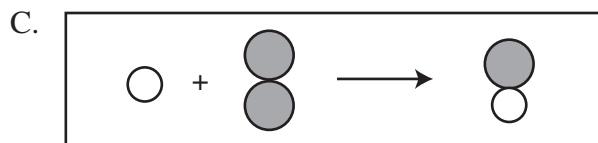
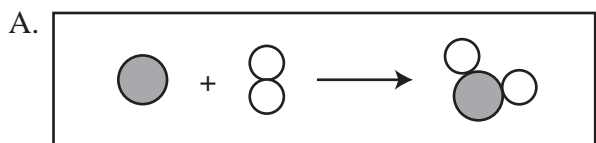

4 A manufacturer wants to produce a container for food storage that does not break easily and is airtight, inexpensive, and microwave-safe. Which of the following is the **best** material to use to make the container?

- A. glass
- B. metal
- C. paper
- D. plastic

5 Heat from deep in Earth's interior is transferred to its crust by which of the following?

- A. conduction in the ocean
- B. convection in the mantle
- C. radiation from the solid core
- D. evaporation at mid-ocean ridges

6 Which of the following bridges is an example of a suspension bridge?

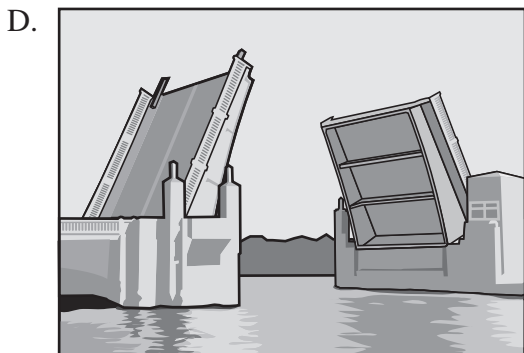
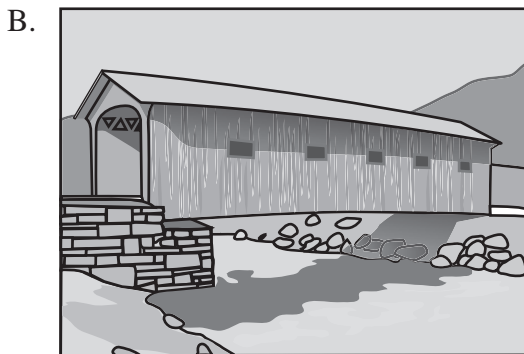
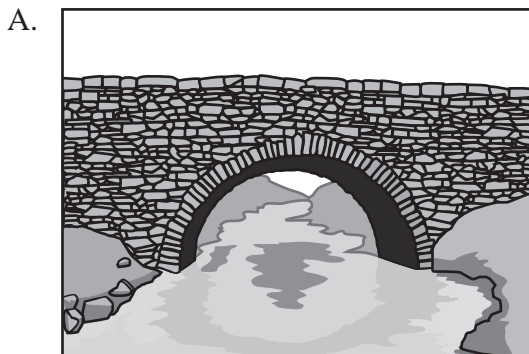

7 The map of Massachusetts below shows where physical evidence of changes can be found.

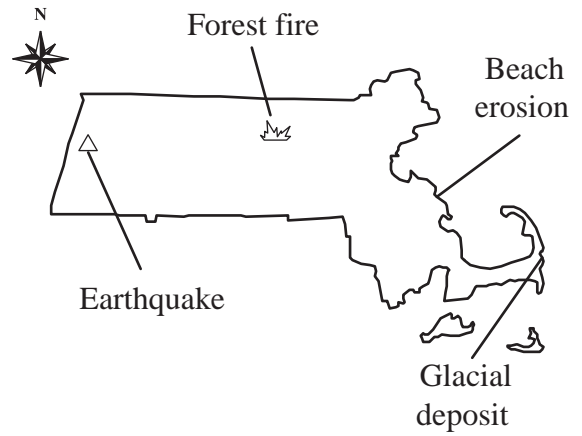

Which of these is the **best** indication that Massachusetts' climate has changed over time?

- A. earthquake
- B. forest fire
- C. beach erosion
- D. glacial deposit

8 Which of the following is the **primary** advantage of sexual reproduction when compared to asexual reproduction?

- A. There is a greater number of offspring.
- B. There is more food available to offspring.
- C. There is greater genetic variety in offspring.
- D. There is a longer development time for offspring.

- 9 The ocean water near the equator absorbs more heat throughout the year than ocean water near the North Pole. Which of the following **best** explains this difference?
- A. The equator is closer to the Sun.
 - B. The equator has higher sea levels.
 - C. The equator receives more direct sunlight.
 - D. The equator rotates more quickly on Earth's axis.
- 10 Which of the following is an example of a physical change but **not** a chemical change?
- A. A log gives off heat and light as it burns.
 - B. A tree stores energy from the Sun in its fruit.
 - C. A penny lost in the grass slowly changes color.
 - D. A water pipe freezes and cracks on a cold night.
- 11 Which of the following Earth layers has the **greatest** density?
- A. crust
 - B. mantle
 - C. inner core
 - D. outer core

- 12 Which of the following is an example of the formation of a mixture?
- A. rust forming on an iron nail
 - B. sugar crystals dissolving in water
 - C. sodium and chlorine forming table salt
 - D. hydrogen and oxygen reacting to produce water
- 13 Which of the following identifies the **primary** function of a radio station tower in a communication system?
- A. decoder
 - B. encoder
 - C. receiver
 - D. transmitter
- 14 Laura adds 50 mL of boiling water to 100 mL of ice water. If the 150 mL of water is then put into a freezer, at what temperature will the water freeze?
- A. 0°C
 - B. 15°C
 - C. 37°C
 - D. 50°C

15 Which of the following substances can be separated into several elements?

- A. nitrogen
- B. zinc
- C. air
- D. aluminum

16 Scientists working for a company are testing a new medicine that they think will help heal damaged tissue. In which part of the company are the scientists working?

- A. distribution
- B. mass marketing
- C. public relations
- D. research

17 Which of the following statements **best** explains why earthquakes occur more frequently in California than in Massachusetts?

- A. The rock found in California is igneous, but the rock found in Massachusetts is sedimentary.
- B. California is located on the boundary of two crustal plates, but Massachusetts is not.
- C. The rock under California is soft, but the rock under Massachusetts is hard.
- D. California is located on a continental plate, but Massachusetts is not.

Questions 18 and 19 are open-response questions.

- **BE SURE TO ANSWER AND LABEL ALL PARTS OF EACH QUESTION.**
- **Show all your work (diagrams, tables, or computations) in your Student Answer Booklet.**
- **If you do the work in your head, explain in writing how you did the work.**

Write your answer to question 18 in the space provided in your Student Answer Booklet.

- 18** The table and descriptions below show some of the characteristics of the planets in our solar system.

Planetary Data*

Planet	Mass (10^{24} kg)	Diameter (km)	Density (kg/m^3)	Length of Day ¹ (hours)	Distance from Sun (10^6 km)	Orbital Period ² (days)	Orbital Velocity ³ (km/s)
Mercury	0.330	4879	5427	4222.6	57.9	88.0	47.9
Venus	4.87	12,104	5243	2802.0	108.2	224.7	35.0
Earth	5.97	12,756	5515	24.0	149.6	365.2	29.8
Mars	0.642	6794	3933	24.7	227.9	687.0	24.1
Jupiter	1899	142,984	1326	9.9	778.6	4331	13.1
Saturn	568	120,536	687	10.7	1433.5	10,747	9.7
Uranus	86.8	51,118	1270	17.2	2872.5	30,589	6.8
Neptune	102	49,528	1638	16.1	4495.1	59,800	5.4
Pluto (dwarf)	0.0125	2390	1750	153.3	5870.0	90,588	4.7

* Numerical data based on NASA information.

¹**Length of Day (hours)** – This is the average time in hours that it takes for the Sun to move from the noon position in the sky at a point on the equator back to the same position.

²**Orbital Period (days)** – This is the time in Earth days that it takes for the planet to orbit the Sun.

³**Orbital Velocity (km/s)** – This is the average velocity, or speed, of the planet in kilometers per second as it orbits the Sun.

- Identify the planet that has the greatest density. Include data from the table to support your answer.
- Describe the relationship between a planet's distance from the Sun and its orbital period. Include data from the table for at least **two** planets to support your answer.
- Identify the planet that rotates the fastest on its axis. Include data from the table to support your answer.

Write your answer to question 19 in the space provided in your Student Answer Booklet.

- 19 Individual organisms can be sorted into different kingdoms based on their characteristics. Pictures of six organisms and a table listing four kingdoms are shown below.

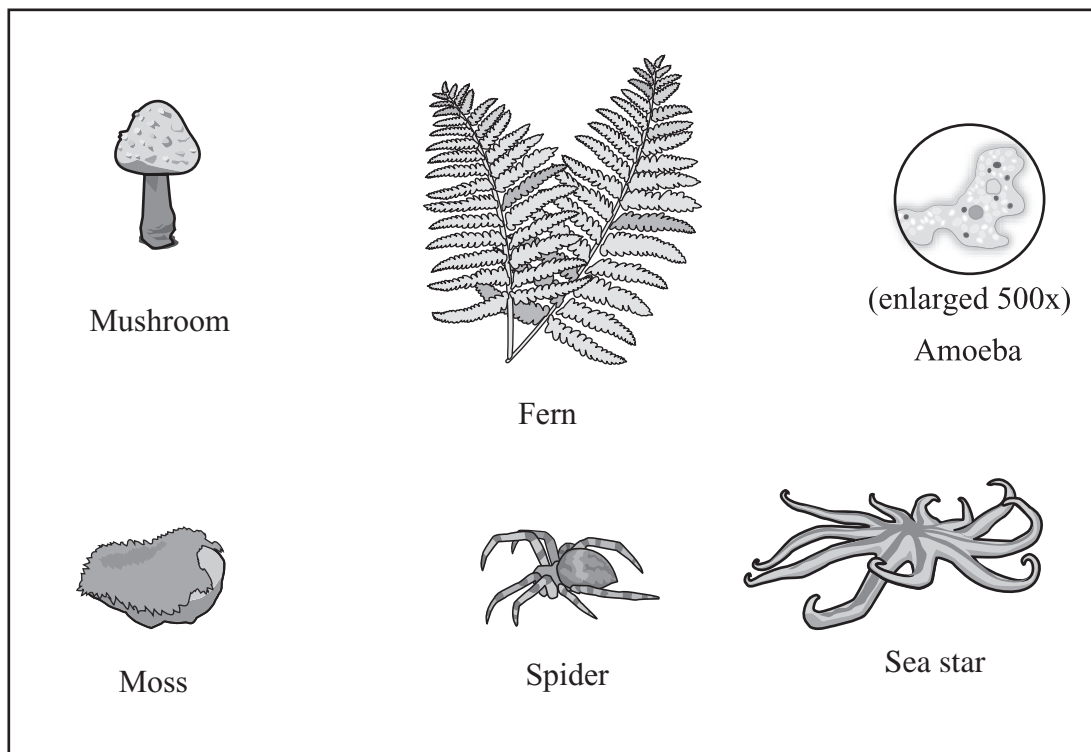

Four Kingdoms of Living Organisms

Animalia	Plantae	Fungi	Protista
SAMPLE ONLY			

- Copy the table above into your Student Answer Booklet.
- Write the name of each pictured organism under the correct kingdom in your copy of the table.
- For each kingdom listed in the table, describe one characteristic that all organisms in that kingdom have in common.

Science and Technology/Engineering

SESSION 2

DIRECTIONS

This session contains seventeen multiple-choice questions and three open-response questions. Mark your answers to these questions in the spaces provided in your Student Answer Booklet.

- 20 The tools shown in the picture below are used in a factory.

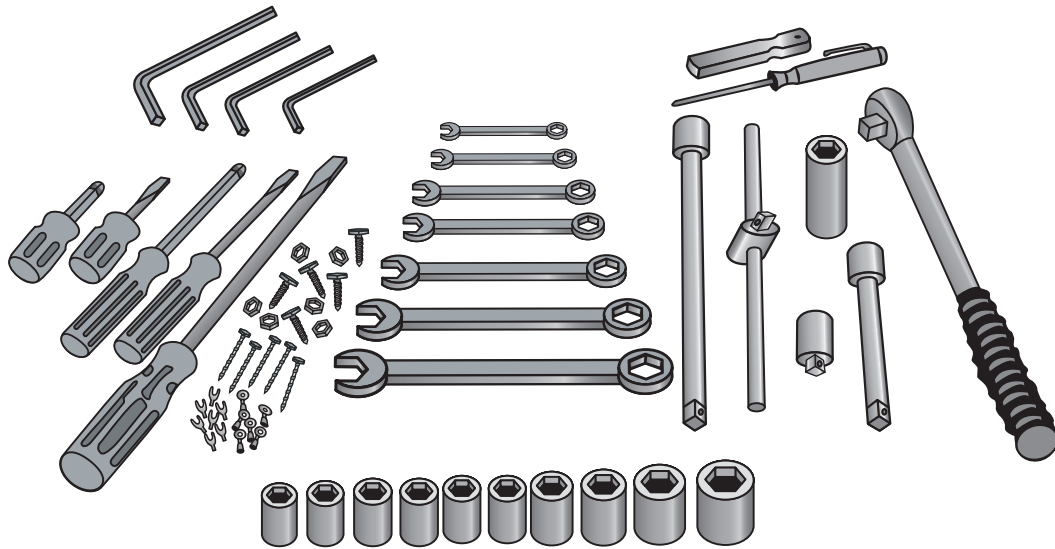

In which of the following manufacturing processes are these tools **most likely** used?

- A. assembling
- B. cutting
- C. finishing
- D. shaping

- 21 Which of the following lists is in order from **smallest** to **largest**?
- A. universe → solar system → galaxy
 - B. galaxy → solar system → universe
 - C. solar system → universe → galaxy
 - D. solar system → galaxy → universe
- 22 An escalator at a shopping mall is 10 m long and moves at a constant speed of 0.5 m/s. If José steps onto the escalator at the bottom while it is moving, how long will it take him to travel the 10 m?
- A. 5 s
 - B. 10 s
 - C. 15 s
 - D. 20 s
- 23 Which of the following areas is **most likely** to form metamorphic rocks such as gneiss and schist?
- A. a sea floor
 - B. a windblown desert
 - C. a site deep underground
 - D. a site covered by a glacier
- 24 Several interchangeable parts are used in the manufacture of automobiles. Some examples of these parts are batteries, windshield wiper blades, spark plugs, and tires.
- Which of the following is an advantage of interchangeable parts over non-interchangeable parts on automobiles?
- A. Interchangeable parts are generally more expensive than custom-made parts for automobiles.
 - B. Interchangeable parts break more often now than in years past on most automobiles.
 - C. Interchangeable parts are plentiful for custom-made automobiles.
 - D. Interchangeable parts can fit many kinds of automobiles.

25 Which of the following diagrams **best** shows the relative positions of Earth, the Moon, and the Sun during a lunar eclipse?

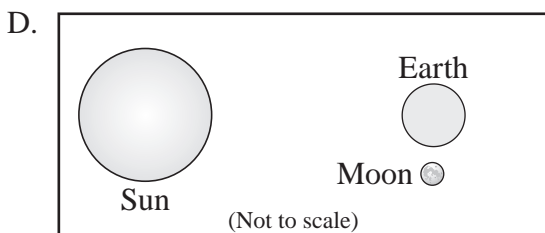
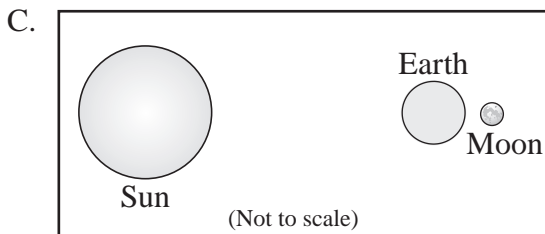
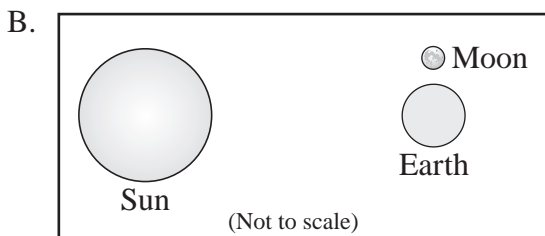
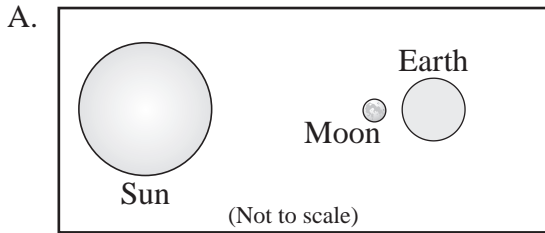

26 Which of the following **best** describes the number of chromosomes in a normal human liver cell?

- A. 23 pairs of chromosomes
- B. 46 different types of chromosomes
- C. 46 male chromosomes and 46 female chromosomes
- D. 23 original chromosomes and 23 duplicate chromosomes

27 Which of the following **best** describes a role of mushrooms in ecosystems?

- A. capturing energy from sunlight
- B. consuming living plant material
- C. taking energy from animal hosts
- D. breaking down dead plant material

28 Which of the following tools is **most** useful for tightening a small mechanical fastener?

- A. chisel
- B. pliers
- C. sander
- D. saw

- 29 Which of the following is a characteristic of **all** chemical changes?
- A. A different state of matter is produced.
 - B. Some mass is converted to energy.
 - C. Some form of light is given off.
 - D. A new material is formed.
- 30 In the human body, which system functions **primarily** to defend the body against disease?
- A. digestive
 - B. immune
 - C. nervous
 - D. respiratory
- 31 What is the smallest unit of an element that still has the properties of that element?
- A. an atom
 - B. a compound
 - C. an electron
 - D. a molecule

- 32 Lichens are symbiotic organisms made of green algae and fungi. What do the green algae supply to the fungi in this symbiotic relationship?
- A. carbon dioxide
 - B. food
 - C. protection
 - D. water
- 33 Which of the following **best** describes an advantage of using a mass production manufacturing system instead of a custom manufacturing system?
- A. Customers can provide specific feedback to workers.
 - B. Workers become skilled in all aspects of assembly.
 - C. Goods can be easily modified for customers.
 - D. Products can be made at a lower cost.

- 34 The diagram below shows some positions in the path of a pendulum swinging from a fixed point called a fulcrum.

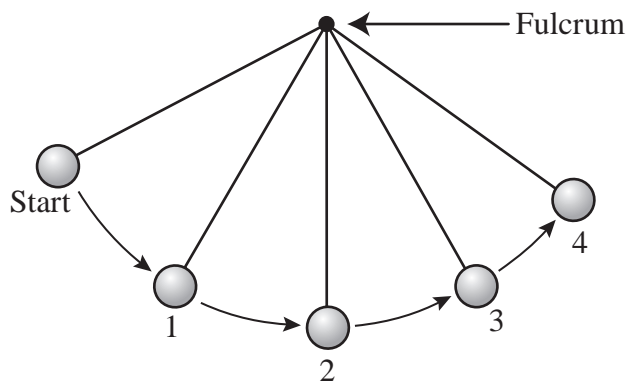

The pendulum is raised to the start position and released. At which two numbered positions is the potential energy of the pendulum **most likely** the same?

- A. position 1 and position 3
- B. position 1 and position 4
- C. position 2 and position 3
- D. position 2 and position 4

- 35 Which of the following describes a reason why companies irradiate some fruits and vegetables before they are sold to the public?

- A. to improve the flavors by increasing the sugar content
- B. to speed up the ripening of produce picked too early
- C. to partially cook the produce before canning or freezing
- D. to extend the shelf life by killing existing microorganisms

- 36 A map with contour lines is shown below.

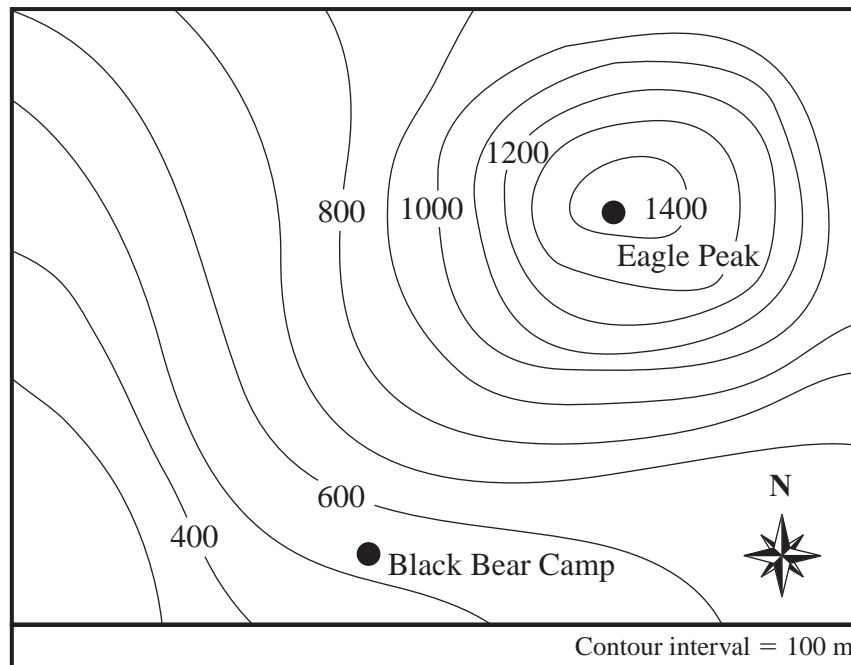

Which of the following is the **best** estimate of the difference in elevation between Black Bear Camp and Eagle Peak?

- A. 400 m
- B. 900 m
- C. 1200 m
- D. 1500 m

Questions 37 through 39 are open-response questions.

- **BE SURE TO ANSWER AND LABEL ALL PARTS OF EACH QUESTION.**
- **Show all your work (diagrams, tables, or computations) in your Student Answer Booklet.**
- **If you do the work in your head, explain in writing how you did the work.**

Write your answer to question 37 in the space provided in your Student Answer Booklet.

- 37 The organisms in an ecosystem interact in many ways to survive. For example, a rosebush, aphids, beetles, spiders, and orioles all interact in a rosebush ecosystem. The diagram below shows how these organisms interact in a partial food web.

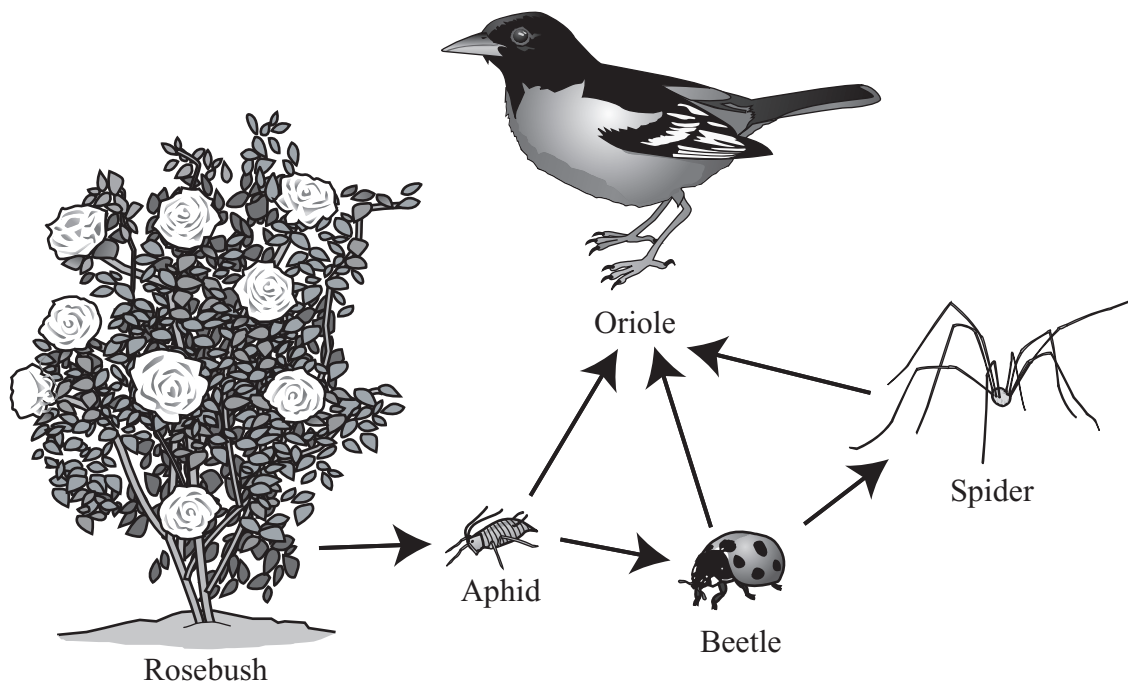

- Identify the producer organism in this food web. Explain the reasoning for your answer.
- Identify the primary consumer organism in this food web. Explain the reasoning for your answer.
- Describe what would **most likely** happen to each of the other organisms in the food web if the beetle population were suddenly destroyed. Explain the reasoning for your answer for each organism.

Write your answer to question 38 in the space provided in your Student Answer Booklet.

- 38 The diagram below shows a model in an open container. The model represents the arrangement of particles of matter in a solid phase.

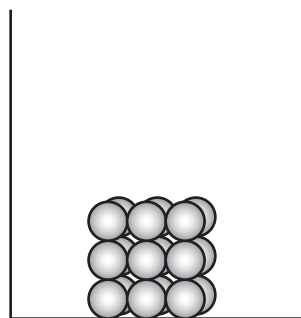

Solid

- Draw a diagram showing the arrangement of these particles in a liquid phase. Explain why the particles have this arrangement. Be sure to describe the energy of the particles.
- Draw a diagram showing the arrangement of these particles in a gas phase. Explain why the particles have this arrangement. Be sure to describe the energy of the particles.

Write your answer to question 39 in the space provided in your Student Answer Booklet.

- 39 The diagram below shows a Formula 1 racing car. Many forces act together on the racing car so it can move safely at high speeds on a racetrack.

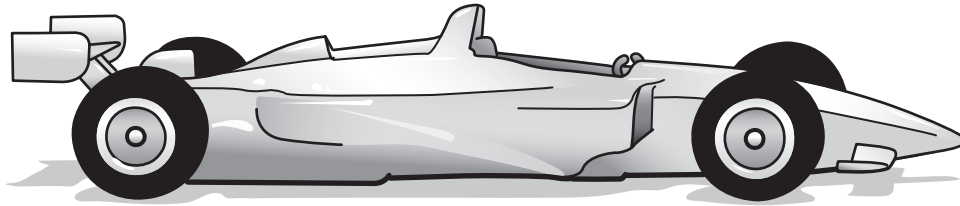

- a. Copy the simple diagram of a racing car shown below into your Student Answer Booklet.

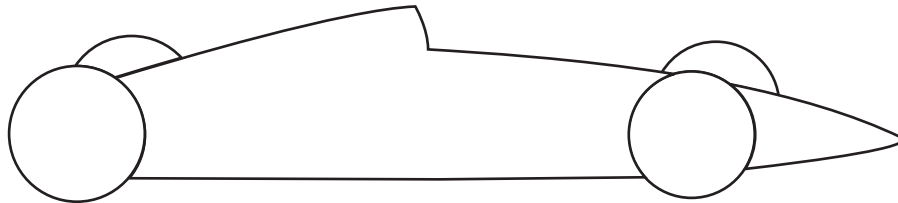

- b. Using your copy of the diagram, draw arrows to show how the forces of thrust, drag, and gravity act on the racing car as it moves forward on a racetrack. Label each arrow as thrust, drag, or gravity.
- c. Describe how **each** force that you labeled in part (b) acts on the racing car as it moves on a racetrack.

**Grade 8 Science and Technology/Engineering
Spring 2007 Released Items:
Reporting Categories, Standards, and Correct Answers**

Item No.	Page No.	Reporting Category	Standard	Correct Answer (MC)*
1	437	<i>Earth and Space Science</i>	8	B
2	437	<i>Life Science (Biology)</i>	16	D
3	438	<i>Physical Sciences (Chemistry and Physics)</i>	4	A
4	438	<i>Technology/Engineering</i>	1.1	D
5	438	<i>Earth and Space Science</i>	3	B
6	439	<i>Technology/Engineering</i>	5.2	C
7	439	<i>Earth and Space Science</i>	7	D
8	439	<i>Life Science (Biology)</i>	10	C
9	440	<i>Earth and Space Science</i>	4	C
10	440	<i>Physical Sciences (Chemistry and Physics)</i>	10	D
11	440	<i>Earth and Space Science</i>	2	C
12	441	<i>Physical Sciences (Chemistry and Physics)</i>	8	B
13	441	<i>Technology/Engineering</i>	3.1	D
14	441	<i>Physical Sciences (Chemistry and Physics)</i>	9	A
15	442	<i>Physical Sciences (Chemistry and Physics)</i>	8	C
16	442	<i>Technology/Engineering</i>	4.3	D
17	442	<i>Earth and Space Science</i>	5	B
18	443	<i>Earth and Space Science</i>	10	
19	444	<i>Life Science (Biology)</i>	1	
20	445	<i>Technology/Engineering</i>	4.4	A
21	446	<i>Earth and Space Science</i>	12	D
22	446	<i>Physical Sciences (Chemistry and Physics)</i>	11	D
23	446	<i>Earth and Space Science</i>	6	C
24	446	<i>Technology/Engineering</i>	4.2	D
25	447	<i>Earth and Space Science</i>	9	C
26	447	<i>Life Science (Biology)</i>	8	A
27	447	<i>Life Science (Biology)</i>	15	D
28	447	<i>Technology/Engineering</i>	1.2	B
29	448	<i>Physical Sciences (Chemistry and Physics)</i>	10	D
30	448	<i>Life Science (Biology)</i>	6	B
31	448	<i>Physical Sciences (Chemistry and Physics)</i>	6	A
32	449	<i>Life Science (Biology)</i>	13	B
33	449	<i>Technology/Engineering</i>	4.1	D
34	450	<i>Physical Sciences (Chemistry and Physics)</i>	13	A
35	450	<i>Technology/Engineering</i>	7.2	D
36	451	<i>Earth and Space Science</i>	1	B
37	452	<i>Life Science (Biology)</i>	14	
38	453	<i>Physical Sciences (Chemistry and Physics)</i>	15	
39	454	<i>Technology/Engineering</i>	6.4	

* Answers are provided here for multiple-choice items only. Sample responses and scoring guidelines for open-response items, which are indicated by shaded cells, will be posted to the Department's Web site later this year.

XVIII. Biology, High School

High School Biology Test

The spring 2007 high school MCAS Biology test was based on learning standards in the Biology content strand of the Massachusetts *Science and Technology/Engineering Curriculum Framework* (2006). These learning standards appear on pages 54–58 of the *Framework*.

The *Science and Technology/Engineering Curriculum Framework* is available on the Department Web site at www.doe.mass.edu/frameworks/current.html.

In *Test Item Analysis Reports* and on the Subject Area Subscore pages of the *MCAS School Reports* and *District Reports*, Biology test results are reported under the following five MCAS reporting categories:

- Biochemistry and Cell Biology
- Genetics
- Anatomy and Physiology
- Ecology
- Evolution and Biodiversity

Test Sessions

The MCAS high school Biology test included two separate test sessions, which were administered on consecutive days. Each session included multiple-choice and open-response questions.

Reference Materials and Tools

The high school Biology test was designed to be taken without the aid of a calculator. Students were allowed to have calculators with them during testing, but calculators were not needed to answer questions.

The use of bilingual word-to-word dictionaries was allowed for current and former limited English proficient students only, during both Biology test sessions. No other reference tools or materials were allowed.

Cross-Reference Information

The table at the conclusion of this chapter indicates each item's reporting category and the *Framework* learning standard it assesses. The correct answers for multiple-choice questions are also displayed in the table.

Biology

SESSION 1

DIRECTIONS

This session contains twenty-three multiple-choice questions and three open-response questions. Mark your answers to these questions in the spaces provided in your Student Answer Booklet. You may work out solutions to multiple-choice questions in the test booklet.

- 1 If scientists search other planets for possible life, they are likely to focus on the presence of molecules containing which of the following elements?
- A. carbon
 - B. iron
 - C. potassium
 - D. sodium
- 2 What is the **primary** function of the large intestine?
- A. to digest proteins
 - B. to absorb nutrients
 - C. to break down complex carbohydrates
 - D. to remove water from undigested waste
- 3 Which of the following **best** describes the result of a mutation in an organism's DNA?
- A. The mutation may produce a zygote.
 - B. The mutation may cause phenotypic change.
 - C. The mutation causes damage when it occurs.
 - D. The mutation creates entirely new organisms.
- 4 Starting in 1954, commercial fishers in the northwest Pacific were paid by weight, rather than by the individual fish, for pink salmon. The fishers increased the use of a type of net that selectively catches larger fish.
- Which of the following effects did this change in fishing techniques **most likely** have on the salmon population over the next 20 years?
- A. The average body size of the salmon population increased significantly.
 - B. The average body size of the salmon population decreased significantly.
 - C. The average body size of the males in the salmon population increased and the average body size of females in the salmon population stayed the same.
 - D. The average body size of the males in the salmon population stayed the same and the average body size of the females in the salmon population increased.

5 The diagrams below show a marine food web and an incomplete terrestrial food web.

Marine Food Web

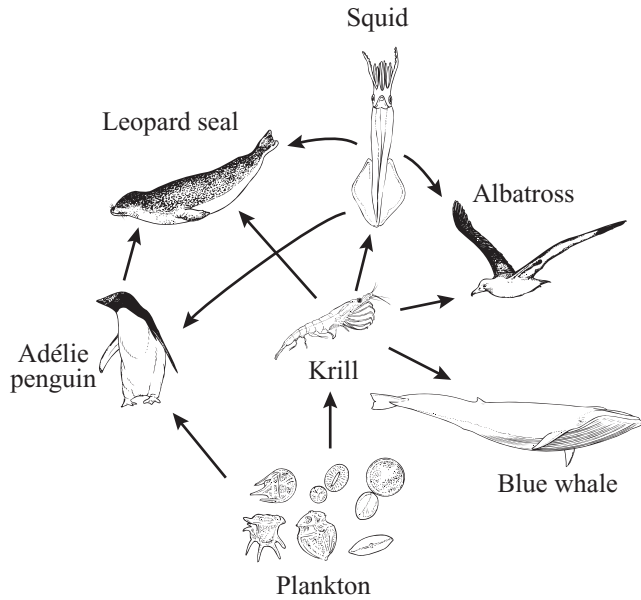

Terrestrial Food Web

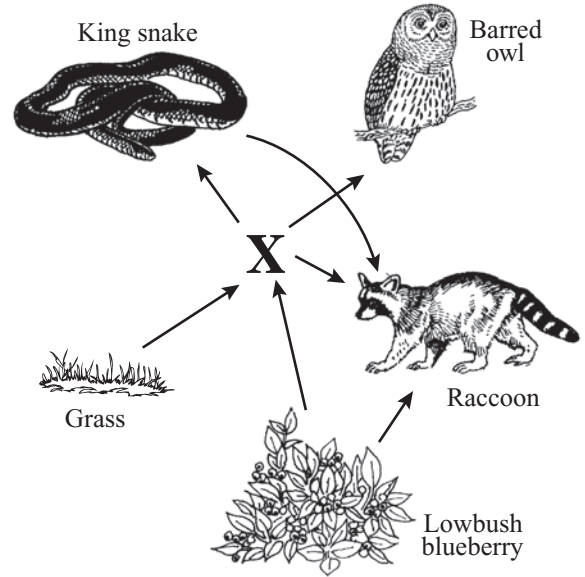

The organism in the terrestrial food web that corresponds to the krill in the marine food web is labeled X. Which of the following organisms is **most likely** organism X?

A.

Mouse



C.

Oak tree



B.

Fox



D.

Hawk



- 6 The pedigree below shows the occurrence of Becker muscular dystrophy in a family. Becker muscular dystrophy causes muscle weakness.

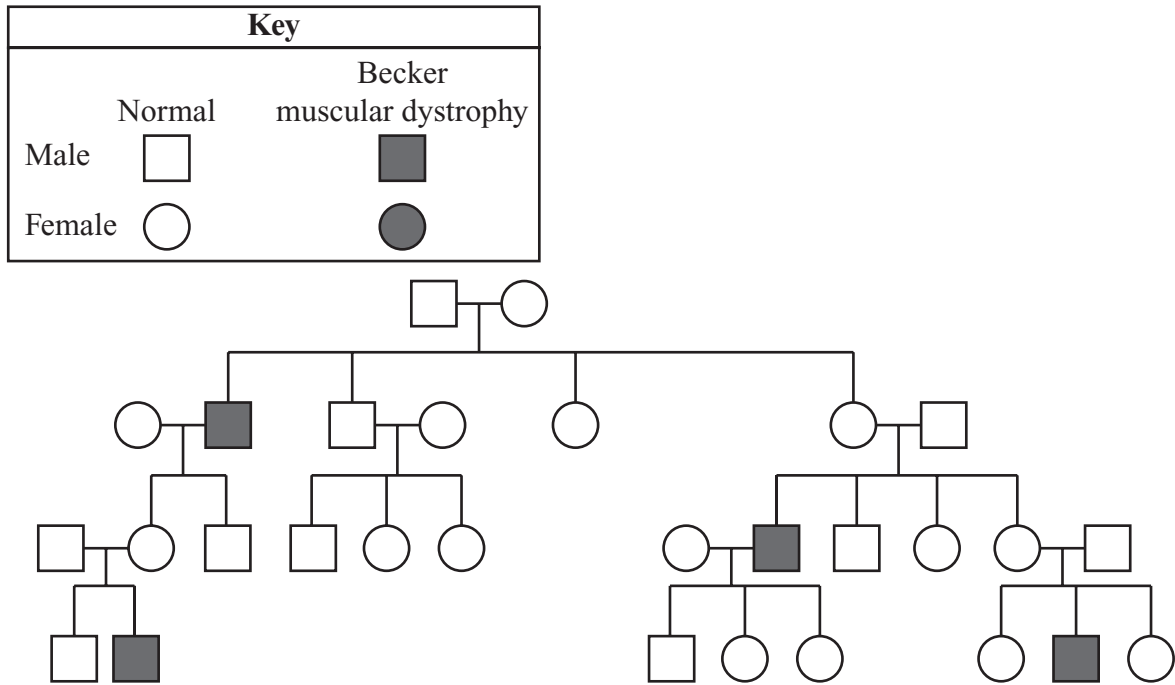

Based on this pedigree, it is **most** reasonable to conclude that Becker muscular dystrophy is which of the following?

- A. a polygenic trait
- B. a codominant trait
- C. a sex-linked recessive trait
- D. an autosomal dominant trait

- 7 A hurricane sweeps across a small Caribbean island, killing 50 percent of the herbivore species on the island. Which of the following is the most immediate result?
- A. a reduction in biodiversity
 - B. an acceleration of the carbon cycle
 - C. an increase in predator populations
 - D. a decline in decomposer populations
- 8 *Caytonia* is an extinct plant that existed between 200 and 140 million years ago. It had reproductive structures that resemble structures in modern flowering plants. How do scientists know about the structures of this ancient extinct plant?
- A. Scientists study the DNA sequences of *Caytonia*.
 - B. Scientists genetically engineer modern plants to produce *Caytonia*.
 - C. Scientists excavate and examine the fossilized remains of *Caytonia*.
 - D. Scientists observe the adaptations of plants in habitats resembling those of *Caytonia*.
- 9 Many land plants store energy in starch. When energy is needed, the starch molecules can be broken down quickly. This chemical reaction produces which of the following?
- A. amino acids
 - B. lipids
 - C. monosaccharides
 - D. RNA chains
- 10 Which of the following **best** describes the formation of a zygote?
- A. A sperm cell nucleus and an egg cell nucleus fuse.
 - B. A cell's DNA replication and mitosis are accelerated.
 - C. A succession of cell divisions produces a solid mass of cells.
 - D. A cell with 46 chromosomes divides to form cells with 23 chromosomes each.

Question 11 is an open-response question.

- **BE SURE TO ANSWER AND LABEL ALL PARTS OF THE QUESTION.**
- **Show all your work (diagrams, tables, or computations) in your Student Answer Booklet.**
- **If you do the work in your head, explain in writing how you did the work.**

Write your answer to question 11 in the space provided in your Student Answer Booklet.

- 11** The illustrations below show a South American finch and some of the species of finches found on the Galápagos Islands. The map shows the relationship of the Galápagos Islands to the west coast of South America.

South American Finch

Food source:
small seeds



Three Types of Galápagos Finches

Food source:
small insects



Food source:
cactus flowers,
fruit, and nectar



Food source:
large seeds



GALÁPAGOS ISLANDS



← 1000 km →

SOUTH AMERICA

N

There are 13 species of finches found on the Galápagos Islands. These finches have a wide variety of food sources and beak shapes. There is one genetically similar species of finch found on the South American mainland. This finch eats small seeds.

Use the map and the bird illustrations to identify and explain **two** ways that these finches provide evidence that supports the theory of evolution.

Mark your answers to multiple-choice questions 12 through 20 in the spaces provided in your Student Answer Booklet. Do not write your answers in this test booklet, but you may work out solutions to multiple-choice questions in the test booklet.

- 12 A graph of atmospheric carbon dioxide concentration over time is shown below.

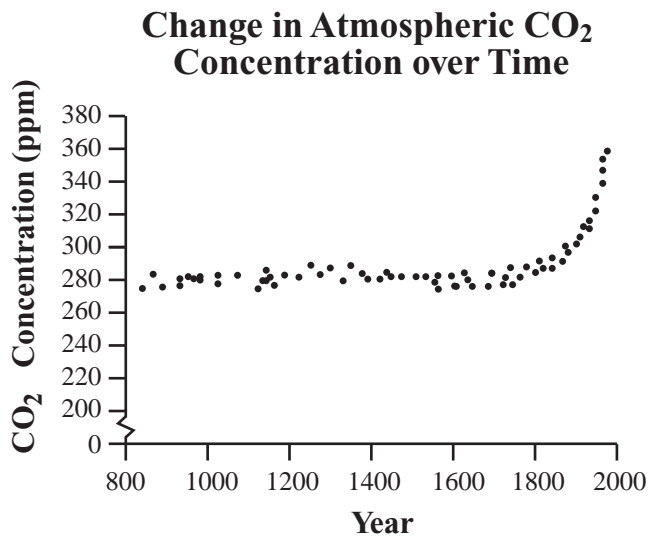

Scientists are investigating the cause of the large increase in atmospheric carbon dioxide concentration since about 1800. Which of the following provides the **best** explanation for the increase?

- A. eruptions of large volcanoes
- B. use of fossil fuels by humans
- C. natural fluctuations of climate
- D. photosynthesis by phytoplankton

- 13 Which of the following functions does active transport perform in a cell?

- A. packaging proteins for export from the cell
- B. distributing enzymes throughout the cytoplasm
- C. moving substances against a concentration gradient
- D. equalizing the concentration of water inside and outside the cell

- 14 European rabbits were introduced to Australia in 1859. The rabbits reproduced rapidly in their new habitat, displaced other animals, and overgrazed vegetation. In an attempt to reduce the rabbit population, a virus was introduced in 1951. This virus is usually deadly to European rabbits.

When the virus was first introduced, the rabbits died in large numbers, but the death rate decreased over time. Which of the following **best** explains the decrease in the rabbit death rate?

- A. Young rabbits learned to avoid being infected with this virus.
- B. Natural selection favored rabbits that are resistant to this virus.
- C. The lifespan of this virus is too short to affect rabbits over a long period of time.
- D. The rabbits that were originally infected with this virus have been dead for many years.

- 15 Which of the following is a main function of the cell wall?

- A. to store carbohydrates for later use
- B. to give the cell a rigid structure
- C. to package proteins for export
- D. to carry out photosynthesis

- 16 The mold *Aspergillus flavus* grows on grain. *A. flavus* produces a toxin that binds to DNA in the bodies of animals that eat the grain.

The binding of the toxin to DNA blocks transcription, so it **directly** interferes with the ability of an animal cell to do which of the following?

- A. transport glucose across the cell membrane into the cytoplasm
- B. produce ATP using energy released from glucose and other nutrients
- C. transfer proteins from the endoplasmic reticulum to Golgi complexes
- D. send protein-building instructions from the nucleus to the cytoplasm and ribosomes

- 17 In a mouse population inhabiting a grassland area, a mutation occurs that results in a new coat color allele.
- Which of the following factors has the **greatest** effect on whether the new coat color will become more common in the mouse population?
- A. whether abundant food is available in the grassland
 - B. whether the new coat color allele is dominant or recessive
 - C. whether the rate of reproduction in the mouse population is stable
 - D. whether the new coat color allele increases the survival of mice in their environment

- 18 Capillaries are part of which body system?
- A. skeletal system
 - B. nervous system
 - C. digestive system
 - D. circulatory system

- 19 Similar structures are present in the embryos of fish, chickens, and rabbits. In fish, these structures develop into gills, but in chickens and rabbits, they either disappear or develop into other body parts later in embryonic development.
- Which of the statements below **best** explains the presence of these structures in the embryos of all three species?
- A. The embryos of the three species are similar in size.
 - B. Breathing structures are similar among the young of the three species.
 - C. The three species have a common ancestor with these embryonic structures.
 - D. The reproductive mechanisms are similar among the adults of the three species.

- 20 Human blood types are genetically determined. The table below shows the symbols used to represent two of the alleles for blood types and gives a description of each allele.

**Two Alleles Controlling
Human Blood Type**

Symbol	Allele Description
I^A	produces antigen A on red blood cells
I^B	produces antigen B on red blood cells

In homozygous individuals, two I^A alleles result in blood type A and two I^B alleles result in blood type B. The I^A and I^B alleles are codominant, resulting in blood type AB in individuals heterozygous for the two alleles.

A male and a female both have blood type AB. If they have a child, what is the probability that the child will also have blood type AB?

- A. $\frac{1}{4}$
- B. $\frac{1}{2}$
- C. $\frac{3}{4}$
- D. $\frac{1}{1}$

The following section focuses on the interactions of organisms in a food web.

Read the information below and use it to answer the four multiple-choice questions and one open-response question that follow.

A partial food web for organisms in Yellowstone National Park is shown below.

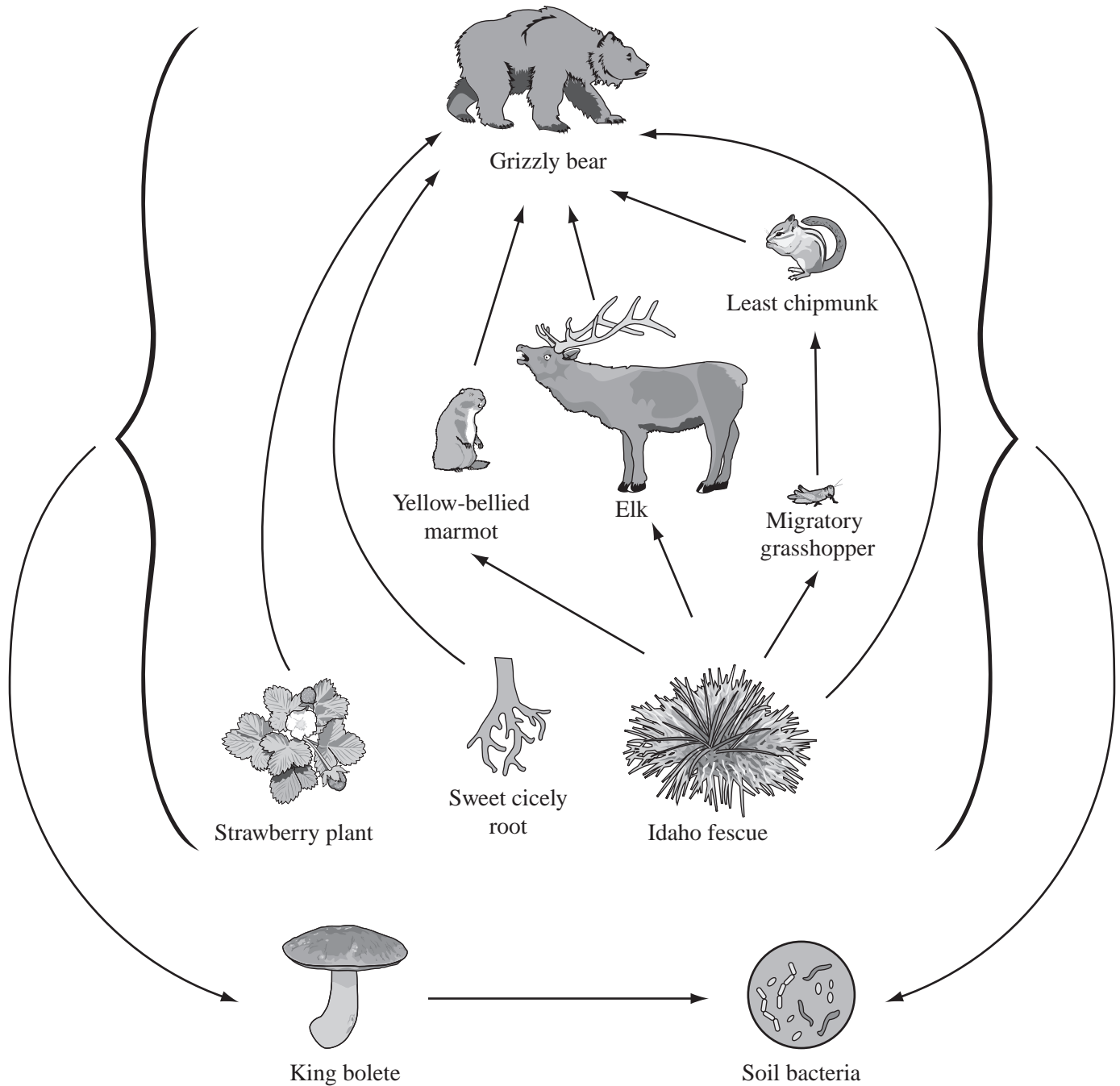

Mark your answers to multiple-choice questions 21 through 24 in the spaces provided in your Student Answer Booklet. Do not write your answers in this test booklet, but you may work out solutions to multiple-choice questions in the test booklet.

- 21 Which process do the animals in the food web use to convert energy from food into ATP?
- A. cellular respiration
 - B. osmosis
 - C. photosynthesis
 - D. transcription
- 22 Which organism in the food web is classified into kingdom Fungi?
- A. Idaho fescue
 - B. king bolete
 - C. migratory grasshopper
 - D. yellow-bellied marmot
- 23 Which of the following organisms is a secondary consumer in this food web?
- A. yellow-bellied marmot
 - B. strawberry plant
 - C. least chipmunk
 - D. king bolete
- 24 Which of the following releases oxygen into this food web ecosystem?
- A. elk respiration
 - B. Idaho fescue photosynthesis
 - C. sweet cicely root decomposition
 - D. migratory grasshopper reproduction

Question 25 is an open-response question.

- **BE SURE TO ANSWER AND LABEL ALL PARTS OF THE QUESTION.**
- **Show all your work (diagrams, tables, or computations) in your Student Answer Booklet.**
- **If you do the work in your head, explain in writing how you did the work.**

Write your answer to question 25 in the space provided in your Student Answer Booklet.

25 Assume the elk population in Yellowstone National Park increases. Discuss how this increase in elk will **most likely** affect each of the following populations:

- Idaho fescue
- migratory grasshopper
- grizzly bear

Be sure to include specific reasons to support each of your responses.

Question 26 is an open-response question.

- **BE SURE TO ANSWER AND LABEL ALL PARTS OF THE QUESTION.**
- **Show all your work (diagrams, tables, or computations) in your Student Answer Booklet.**
- **If you do the work in your head, explain in writing how you did the work.**

Write your answer to question 26 in the space provided in your Student Answer Booklet.

- 26 In 1950, Erwin Chargaff and colleagues examined the chemical composition of DNA and demonstrated that the amount of adenine always equals that of thymine, and the amount of guanine always equals that of cytosine. This observation became known as Chargaff's rule.
- Based on current knowledge of the structure of DNA, explain the basis of Chargaff's rule.
 - The diagram below represents a single-stranded segment of DNA. In your Student Answer Booklet, write the complementary DNA strand that would form from this strand during replication. Use the letters A, C, G, and T to designate the bases: A = adenine; C = cytosine; G = guanine; T = thymine.

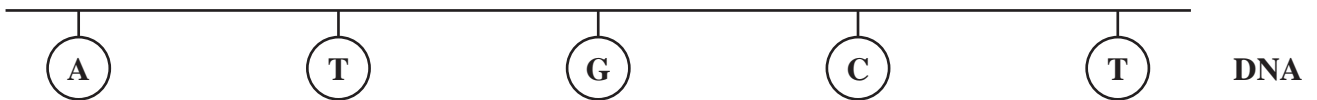

- Why is Chargaff's rule so important to DNA's ability to replicate itself accurately?

Biology

SESSION 2

DIRECTIONS

This session contains seventeen multiple-choice questions and two open-response questions. Mark your answers to these questions in the spaces provided in your Student Answer Booklet. You may work out solutions to multiple-choice questions in the test booklet.

- 27 The illustrations below show vestigial pelvic bones of a baleen whale and vestigial hind limb bones of an extinct whale.

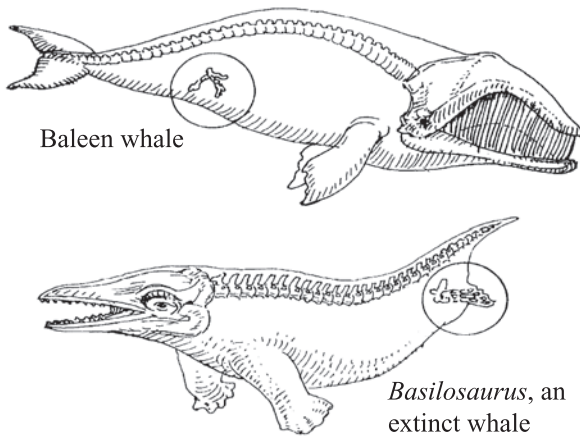

The presence of these bones in the baleen whale and extinct whale provides evidence of which of the following?

- A. Whales can travel on land when necessary.
- B. Whales evolved from four-legged animals.
- C. Whales have functional legs that are hidden by fat and skin.
- D. Whales are developing into animals with four functioning limbs.

- 28 In phenylketonuria (PKU), an enzyme that converts one amino acid into another does not work properly. Which of the following is the **most likely** cause of this genetic condition?

- A. an error in the transcription of the gene for the enzyme
- B. a mutation in the DNA sequence that codes for the enzyme
- C. an excess of the amino acids necessary to produce the enzyme
- D. a structural variation in the amino acid modified by the enzyme

- 29 The water cycle would **not** occur if which of the following were missing?

- A. animals
- B. bacteria
- C. ice caps
- D. solar energy

- 30 Which of the following statements correctly matches a cell part with its function?
- A. The cell membrane packages lipids for export.
 - B. The mitochondria perform photosynthesis.
 - C. The lysosome digests molecules.
 - D. The nucleus produces energy.

- 31 Which of the following is one of the functions of the human skeleton?
- A. producing hormones
 - B. bringing gases into the body
 - C. removing waste from the body
 - D. providing a site for blood cell formation

Question 32 is an open-response question.

- **BE SURE TO ANSWER AND LABEL ALL PARTS OF THE QUESTION.**
- **Show all your work (diagrams, tables, or computations) in your Student Answer Booklet.**
- **If you do the work in your head, explain in writing how you did the work.**

Write your answer to question 32 in the space provided in your Student Answer Booklet.

- 32 The drawing below represents an organism that a student observed when examining a sample of pond water with a light microscope.

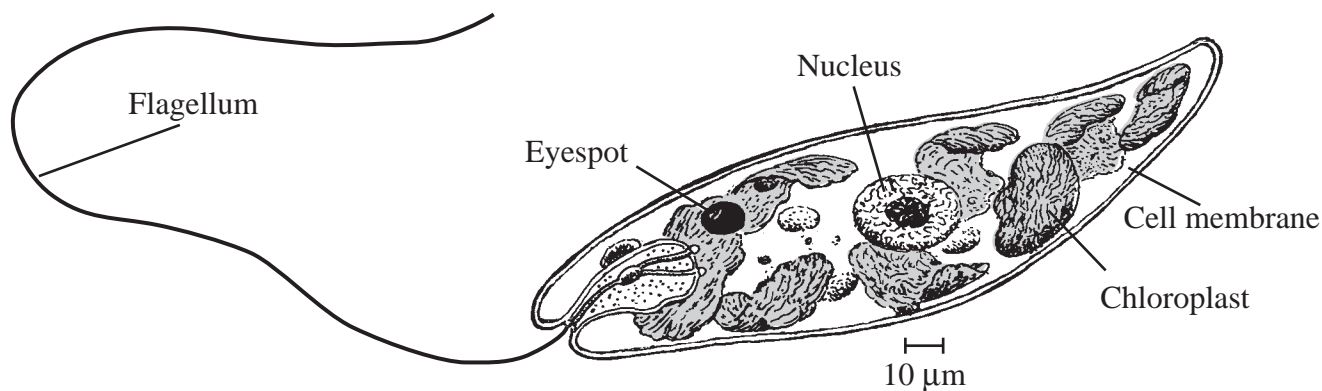

The student identified this organism as a prokaryote.

- Is the student's identification accurate? Explain your answer using information from the diagram.
- Identify **three** similarities between the cells of prokaryotes and eukaryotes.

Mark your answers to multiple-choice questions 33 through 38 in the spaces provided in your Student Answer Booklet. Do not write your answers in this test booklet, but you may work out solutions to multiple-choice questions in the test booklet.

- 33** Some willow trees alter the chemical composition of their leaves when attacked by caterpillars. Compared to normal leaves, the chemically altered leaves are less nutritious and are more difficult for caterpillars to digest.

Which of the following is a likely effect of this ability to alter leaf composition?

- A. Willow trees with this ability will attract more caterpillars than other willow trees.
- B. Willow trees with this ability will have a survival advantage over other willow trees.
- C. More butterflies will lay their eggs on willow trees with this ability than on other willow trees.
- D. Caterpillars that feed on willow trees with this ability will be larger than caterpillars on other willow trees.

- 34** The drawings below show some trilobite and crinoid fossils.

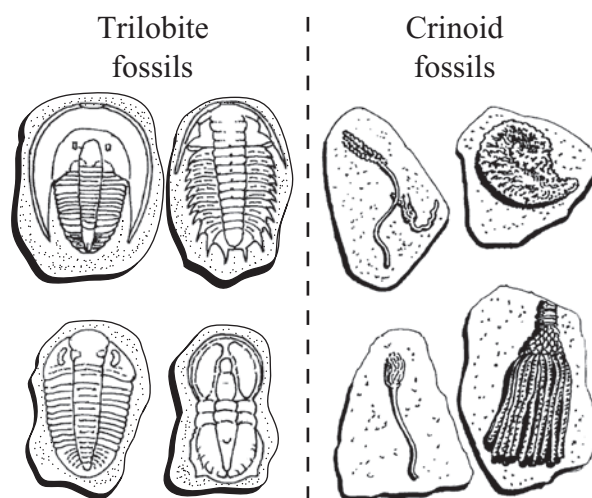

Which of the following is the **most** reasonable conclusion when fossils of these two different types of organisms are found in the same layers of rock?

- A. Crinoids were prey for trilobites.
- B. Crinoids were ancestors of trilobites.
- C. Crinoids and trilobites had similar behaviors.
- D. Crinoids and trilobites lived at the same time.

- 35 In red blood cells, the compound carbonic anhydrase increases the rate at which carbon dioxide is converted to bicarbonate ions for transport in the blood. In red blood cells, carbonic anhydrase acts as which of the following?

A. an enzyme
 B. a hormone
 C. a lipid
 D. a sugar

- 36 The diagram below shows the positions of the genes for flower color and stem length in a pea plant. The chromosomes represented below will replicate before meiosis.

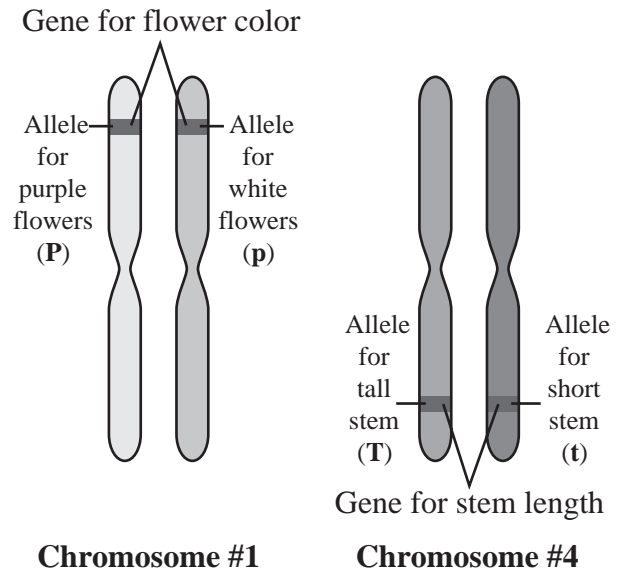

For these two genes, what is the maximum number of different allele combinations that can be formed normally in gametes produced from this cell?

A. 2
 B. 4
 C. 6
 D. 8

37 Many plants have waxy coatings on some surfaces. This coating reduces water loss because it is not water-permeable. This waxy coating is which of the following types of organic molecule?

- A. carbohydrate
- B. lipid
- C. nucleic acid
- D. protein

38 Part of a tundra food web is shown below.

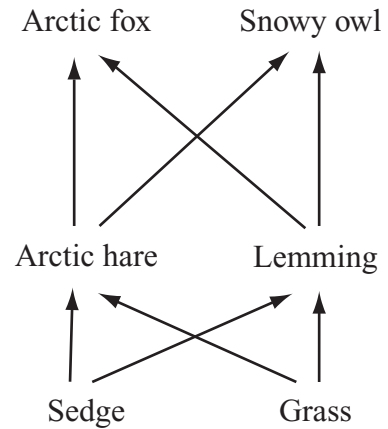

Which of the following describes the relationship between the sedge and the arctic hare?

- A. competition
- B. host-parasite
- C. mutualism
- D. producer-consumer

Question 39 is an open-response question.

- **BE SURE TO ANSWER AND LABEL ALL PARTS OF THE QUESTION.**
- **Show all your work (diagrams, tables, or computations) in your Student Answer Booklet.**
- **If you do the work in your head, explain in writing how you did the work.**

Write your answer to question 39 in the space provided in your Student Answer Booklet.

- 39 When a person exercises, the rate of cellular respiration increases to supply the body with more energy in the form of ATP. Mitochondria require oxygen to carry out cellular respiration.

Describe how the respiratory, circulatory, and muscular systems interact to transport a molecule of oxygen from the air to a mitochondrion. Be sure to discuss all three systems in your response.

Mark your answers to multiple-choice questions 40 through 45 in the spaces provided in your Student Answer Booklet. Do not write your answers in this test booklet, but you may work out solutions to multiple-choice questions in the test booklet.

40 Which of the following terms applies to traits, such as human eye color, that are controlled by more than one gene?

- A. codominant
- B. polygenic
- C. recessive
- D. sex-linked

41 Which of the following is the **best** example of an organism maintaining homeostasis?

- A. a wolf panting after a chase
- B. a spider catching an insect in a web
- C. a cricket becoming infected by a virus
- D. a mole digging tunnels in the ground

42 Which of the following explains why legume plants are less likely than other terrestrial plants to experience nitrogen limitation?

- A. Legume plants need less nitrogen than other plants do.
- B. Legume plants have nitrogen-fixing bacteria on their roots.
- C. Legume plants catch insects to supply themselves with nitrogen.
- D. Legume plants can absorb nitrogen directly from the atmosphere.

43 In pigeons, the allele **B** produces ash-red feathers. The allele **b** produces blue feathers. The **B** allele is dominant to the **b** allele.

A pigeon with genotype **Bb** is crossed with a pigeon with genotype **bb**. What percent of the offspring are expected to have ash-red feathers?

- A. 0%
- B. 25%
- C. 50%
- D. 100%

44 Which of the following is the basic structural unit of the nervous system?

- A. axon
- B. neuron
- C. red blood cell
- D. white blood cell

- 45 The diagram below provides information about a carrot cell.

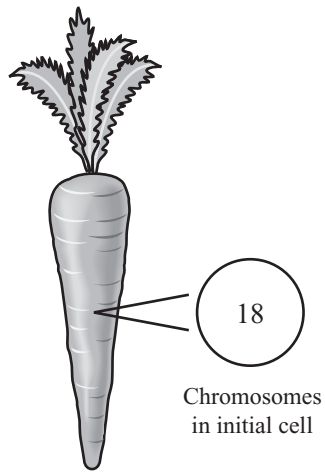

A carrot cell contains 18 chromosomes. Which of the following diagrams illustrates the correct number of chromosomes in new cells produced by mitosis?

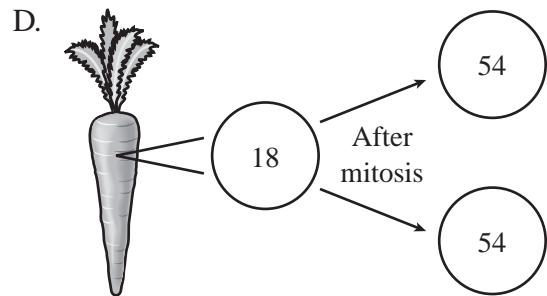
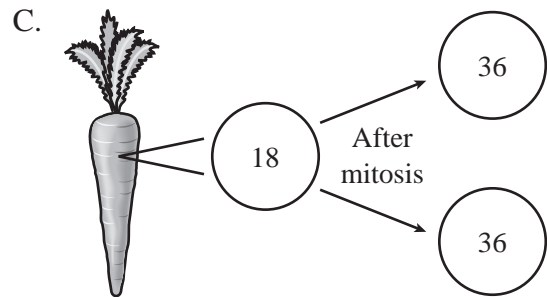
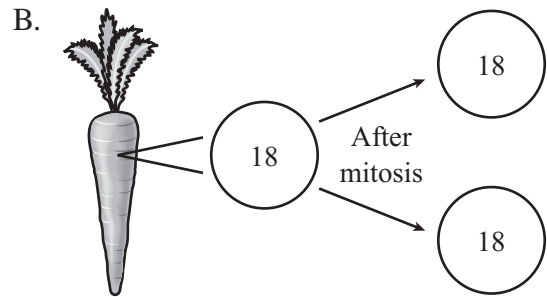
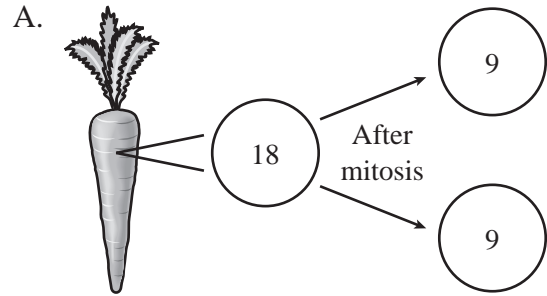

High School Biology
Spring 2007 Released Items:
Reporting Categories, Standards, and Correct Answers

Item No.	Page No.	Reporting Category	Standard	Correct Answer (MC)*
1	459	<i>Biochemistry and Cell Biology</i>	1.1	A
2	459	<i>Anatomy and Physiology</i>	4.1	D
3	459	<i>Genetics</i>	3.3	B
4	459	<i>Evolution and Biodiversity</i>	5.3	B
5	460	<i>Ecology</i>	6.3	A
6	461	<i>Genetics</i>	3.4	C
7	462	<i>Ecology</i>	6.2	A
8	462	<i>Evolution and Biodiversity</i>	5.1	C
9	462	<i>Biochemistry and Cell Biology</i>	1.2	C
10	462	<i>Biochemistry and Cell Biology</i>	2.7	A
11	463	<i>Evolution and Biodiversity</i>	5.1	
12	464	<i>Ecology</i>	6.4	B
13	464	<i>Biochemistry and Cell Biology</i>	2.1	C
14	465	<i>Evolution and Biodiversity</i>	5.3	B
15	465	<i>Biochemistry and Cell Biology</i>	2.1	B
16	465	<i>Genetics</i>	3.2	D
17	466	<i>Evolution and Biodiversity</i>	5.3	D
18	466	<i>Anatomy and Physiology</i>	4.2	D
19	466	<i>Evolution and Biodiversity</i>	5.1	C
20	467	<i>Genetics</i>	3.6	B
21	469	<i>Biochemistry and Cell Biology</i>	2.4	A
22	469	<i>Biochemistry and Cell Biology</i>	2.3	B
23	469	<i>Ecology</i>	6.3	C
24	469	<i>Ecology</i>	6.4	B
25	470	<i>Ecology</i>	6.3	
26	471	<i>Genetics</i>	3.1	
27	472	<i>Evolution and Biodiversity</i>	5.1	B
28	472	<i>Genetics</i>	3.3	B
29	472	<i>Ecology</i>	6.4	D
30	473	<i>Biochemistry and Cell Biology</i>	2.1	C
31	473	<i>Anatomy and Physiology</i>	4.5	D
32	474	<i>Biochemistry and Cell Biology</i>	2.2	
33	475	<i>Evolution and Biodiversity</i>	5.3	B
34	475	<i>Evolution and Biodiversity</i>	5.1	D
35	476	<i>Biochemistry and Cell Biology</i>	1.3	A
36	476	<i>Genetics</i>	3.5	B
37	477	<i>Biochemistry and Cell Biology</i>	1.2	B
38	477	<i>Ecology</i>	6.3	D
39	478	<i>Anatomy and Physiology</i>	4.8	
40	479	<i>Genetics</i>	3.4	B
41	479	<i>Anatomy and Physiology</i>	4.8	A
42	479	<i>Ecology</i>	6.4	B

Item No.	Page No.	Reporting Category	Standard	Correct Answer (MC)*
43	480	<i>Genetics</i>	3.6	C
44	480	<i>Anatomy and Physiology</i>	4.4	B
45	481	<i>Biochemistry and Cell Biology</i>	2.6	B

* Answers are provided here for multiple-choice items only. Sample responses and scoring guidelines for open-response items, which are indicated by shaded cells, will be posted to the Department's Web site later this year.

XIX. Chemistry, High School

High School Chemistry Test

The spring 2007 high school MCAS Chemistry test was based on learning standards in the Chemistry content strand of the Massachusetts *Science and Technology/Engineering Curriculum Framework* (2006). These learning standards appear on pages 69–73 of the *Framework*.

The *Science and Technology/Engineering Curriculum Framework* is available on the Department Web site at www.doe.mass.edu/frameworks/current.html.

In *Test Item Analysis Reports* and on the Subject Area Subscore pages of the MCAS *School Reports* and *District Reports*, Chemistry test results are reported under the following four MCAS reporting categories:

- Atomic Structure and Periodicity
- Bonding and Reactions
- Properties of Matter and Thermochemistry
- Solutions, Equilibrium, and Acid-Base Theory

Test Sessions

The MCAS high school Chemistry test included two separate test sessions, which were administered on consecutive days. Each session included multiple-choice and open-response questions.

Reference Materials and Tools

Each student taking the high school Chemistry test was provided with a Chemistry Formula and Constants Sheet/Periodic Table of the Elements. Copies of both sides of this formula sheet follow the final question in this chapter.

Each student also had sole access to a calculator with at least four functions and a square-root key.

The use of bilingual word-to-word dictionaries was allowed for current and former limited English proficient students only, during both Chemistry test sessions. No other reference tools or materials were allowed.

Cross-Reference Information

The table at the conclusion of this chapter indicates each item's reporting category and the *Framework* learning standard it assesses. The correct answers for multiple-choice questions are also displayed in the table.

Chemistry

SESSION 1

DIRECTIONS

This session contains twenty-three multiple-choice questions and three open-response questions. Mark your answers to these questions in the spaces provided in your Student Answer Booklet. You may work out solutions to multiple-choice questions in the test booklet.

1 Which of the following Lewis dot structures represents the compound methane (CH_4)?

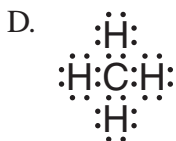
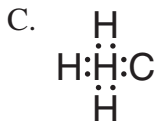
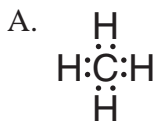

2 Which of the following molecules has the same empirical formula as glucose ($\text{C}_6\text{H}_{12}\text{O}_6$)?

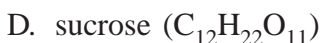

3 $1s^2 2s^2 2p^6 3s^2 3p^6 4s^1$ is the electron configuration for which element?

A. aluminum (Al)

B. argon (Ar)

C. potassium (K)

D. sodium (Na)

4 What is the mass of one mole of helium gas?

A. 2 g

B. 4 g

C. 8 g

D. 22 g

- 5 Which of the following correctly describes molecules of two different gases if they are at the same temperature and pressure?
- A. They must have the same mass.
 - B. They must have the same velocity.
 - C. They must have the same average kinetic energy.
 - D. They must have the same average potential energy.

- 6 Aluminum reacts with oxygen gas to form aluminum oxide, as shown in the reaction below.

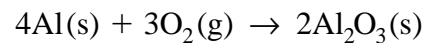

How many grams of aluminum are needed to completely react with 192 g of oxygen gas?

- A. 27.0 g
- B. 102 g
- C. 216 g
- D. 432 g

- 7 The table below gives information about four aqueous solutions of sodium nitrate (NaNO_3).

Beaker	Concentration of NaNO_3 (%)	Temperature ($^\circ\text{C}$)
1	20	0
2	20	40
3	2	80
4	2	100

In which beaker will an additional 10 g of sodium nitrate (NaNO_3) dissolve at the **slowest** rate?

- A. 1
- B. 2
- C. 3
- D. 4

- 8 The equation below shows the radioactive decay of thorium (Th).

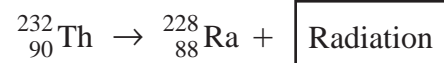

Which of the following particles is released in this reaction?

- A. alpha (${}^4_2\text{He}$)
- B. beta (${}^0_{-1}e$)
- C. neutron (1_0n)
- D. proton (${}^1_1\text{H}$)

- 9 Assuming pressure is held constant, which of the following graphs shows how the volume of an ideal gas changes with temperature?

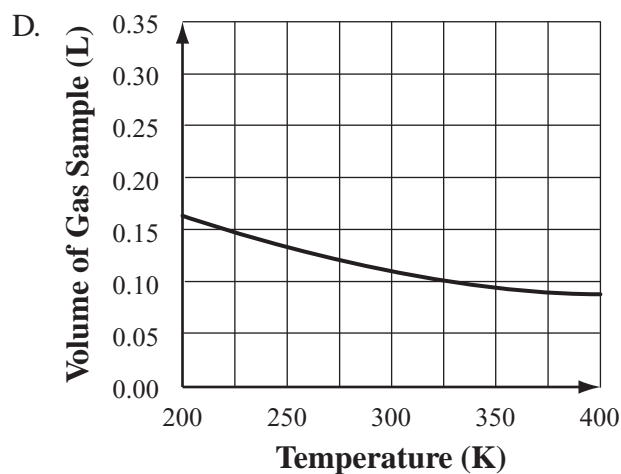
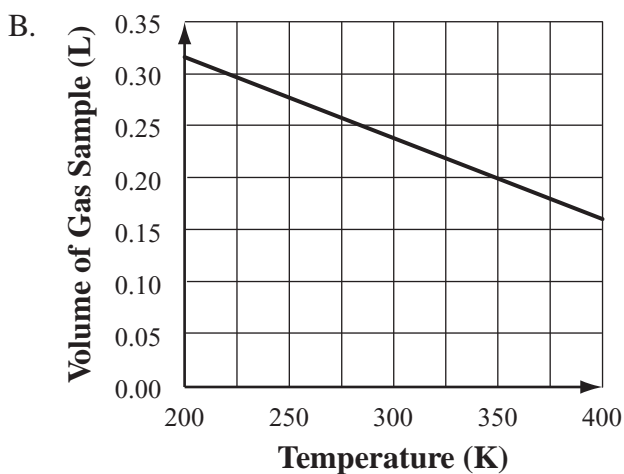
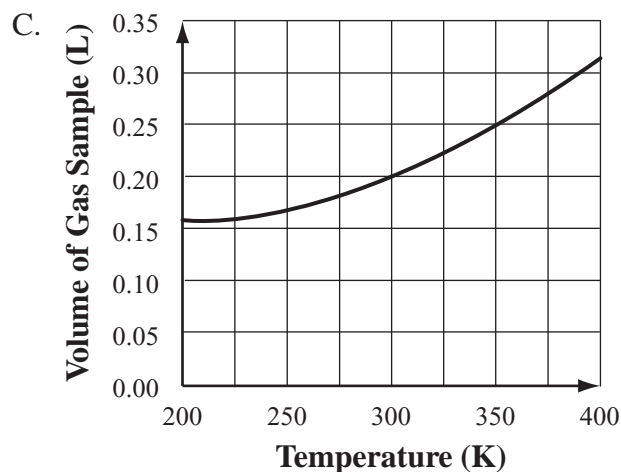
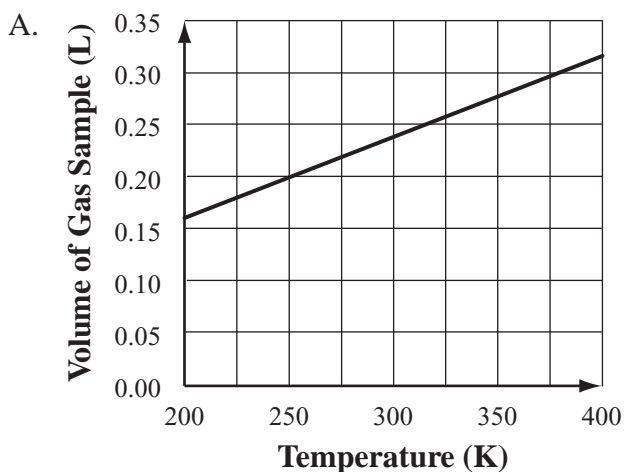

- 10 A solution that contains **less** solute than it can hold at a given temperature is
- A. disassociated.
 - B. saturated.
 - C. supersaturated.
 - D. unsaturated.

Question 11 is an open-response question.

- **BE SURE TO ANSWER AND LABEL ALL PARTS OF THE QUESTION.**
- **Show all your work (diagrams, tables, or computations) in your Student Answer Booklet.**
- **If you do the work in your head, explain in writing how you did the work.**

Write your answer to question 11 in the space provided in your Student Answer Booklet.

- 11 The temperature of an unknown substance was measured as it cooled. The temperature of the substance over time was graphed and the graph was divided into five different zones, as shown below. In zone A, the substance was a gas.

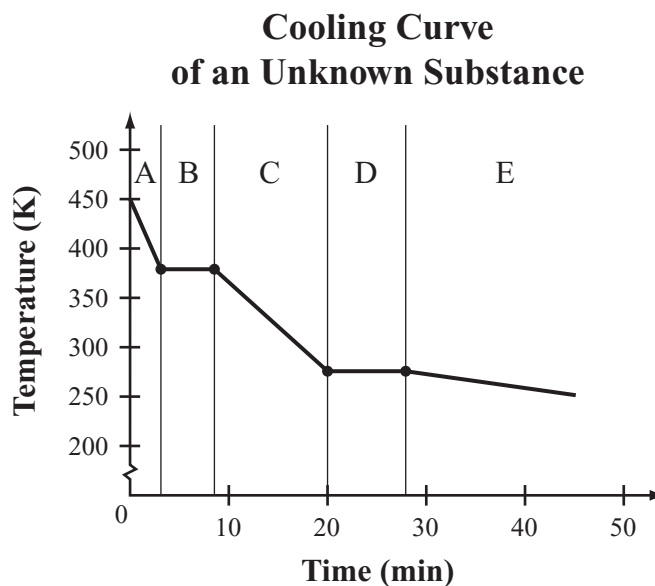

Compare what happened at the particle level in **three** of the four remaining zones: B, C, D, and E.

For **each** zone you choose, discuss all of the following:

- energy of the particles
- motion of the particles
- arrangement of the particles
- state(s) of matter present

Mark your answers to multiple-choice questions 12 through 24 in the spaces provided in your Student Answer Booklet. Do not write your answers in this test booklet, but you may work out solutions to multiple-choice questions in the test booklet.

- 12 The atomic number of an element indicates which of the following?
- A. the number of neutrons in the atom
 - B. the number of protons in the atom
 - C. the sum of the neutrons and protons in the atom
 - D. the sum of the protons and electrons in the atom

- 13 The table below shows some information for four different elements.

Element	Classification	Density (g/cm ³)
barium (Ba)	metal	3.6
beryllium (Be)	metal	1.8
chromium (Cr)	metal	7.2
phosphorus (P)	nonmetal	1.8

A cube of an unknown element has a shiny, silvery color. The side of the cube measures 2.0 cm and the cube has a mass of 14.56 g.

Based on the information in the table, which element makes up the cube?

- A. barium
- B. beryllium
- C. chromium
- D. phosphorus

- 14 What is the percent mass oxygen in acetone (C₃H₆O)?

- A. 1.00%
- B. 10.3%
- C. 27.6%
- D. 62.0%

- 15 Which of the following is **not** true of a sample of gas as it is heated in a rigid, closed container?

- A. The pressure of the molecules increases.
- B. The average speed of the molecules increases.
- C. The average distance between molecules increases.
- D. The number of collisions between molecules increases.

- 16 The figure below represents a reaction.

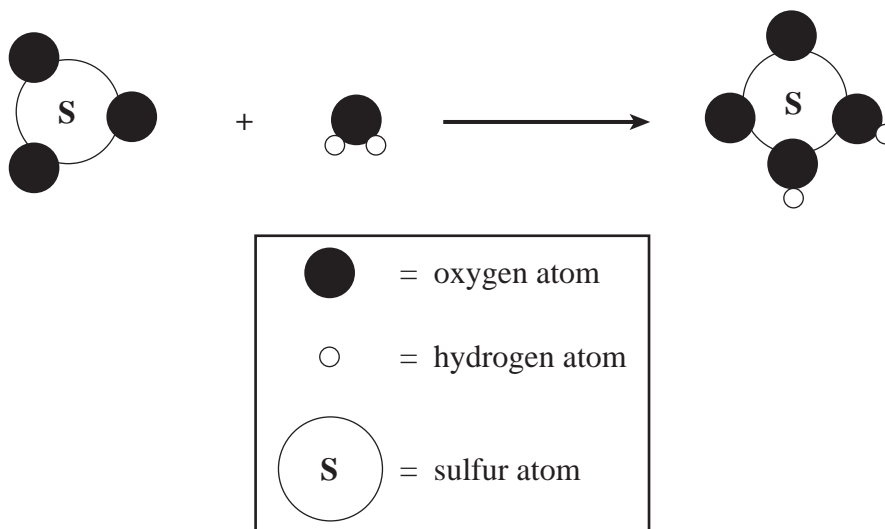

What type of reaction is shown?

- A. synthesis
- B. decomposition
- C. single displacement
- D. double displacement

- 17 The density of a gas is 1.35 g/L at standard temperature and pressure (STP). What is the molar mass of the gas at STP?

- A. 0.0603 g/mol
- B. 6.02 g/mol
- C. 22.4 g/mol
- D. 30.2 g/mol

- 18 The equation below shows ammonia dissolving in water.

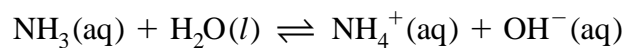

Why is water considered an acid when ammonia is dissolved in it?

- A. Water acts as a proton donor.
- B. Water acts as a proton acceptor.
- C. Water contains hydrogen atoms.
- D. Water has a 2:1 ratio of hydrogen to oxygen.

19 How many atoms are in a 12.0 g sample of lithium?

- A. 1.74×10^{23} atoms
- B. 6.02×10^{23} atoms
- C. 1.04×10^{24} atoms
- D. 7.24×10^{24} atoms

20 The table below contains data for water samples from four sources.

Analysis of Water Samples

Source of Water	Sample Volume (mL)	pH
Rain	5	5.7
Creek	20	7.9
Pool	10	7.4
Faucet	20	6.8

Nancy analyzed water samples from several sources: rainfall, a nearby creek, a swimming pool, and her kitchen faucet. She recorded her data in the table.

Which sample was **most** acidic?

- A. rain
- B. creek
- C. pool
- D. faucet

- 21 An equation for an equilibrium reaction is shown below.



Which of the following changes in reaction conditions will **not** shift the equilibrium of the system?

- A. an increase in the pressure
 - B. an increase in the temperature
 - C. a decrease in the SO_3 concentration
 - D. a decrease in the NO_2 concentration
- 22 The three main types of nuclear radiation are alpha, beta, and gamma. Which of the following lists these types of radiation from highest penetrating power to lowest penetrating power?
- A. alpha, gamma, beta
 - B. beta, alpha, gamma
 - C. beta, gamma, alpha
 - D. gamma, beta, alpha

- 23 Water cools from 2°C to -2°C . During this time, what happens to the motion of the molecules?

- A. The motion of the molecules stops.
- B. The motion of the molecules increases.
- C. The motion of the molecules decreases.
- D. The motion of the molecules remains the same.

- 24 Which of the following elements has characteristics of some metals and also of some nonmetals?

- A. antimony (${}_{51}\text{Sb}$)
- B. calcium (${}_{20}\text{Ca}$)
- C. sulfur (${}_{16}\text{S}$)
- D. zinc (${}_{30}\text{Zn}$)

Questions 25 and 26 are open-response questions.

- **BE SURE TO ANSWER AND LABEL ALL PARTS OF EACH QUESTION.**
- **Show all your work (diagrams, tables, or computations) in your Student Answer Booklet.**
- **If you do the work in your head, explain in writing how you did the work.**

Write your answer to question 25 in the space provided in your Student Answer Booklet.

- 25 An early model of the atom, shown below, incorrectly described the structure of the atom as an area of positive charges with small, negatively charged particles inside.

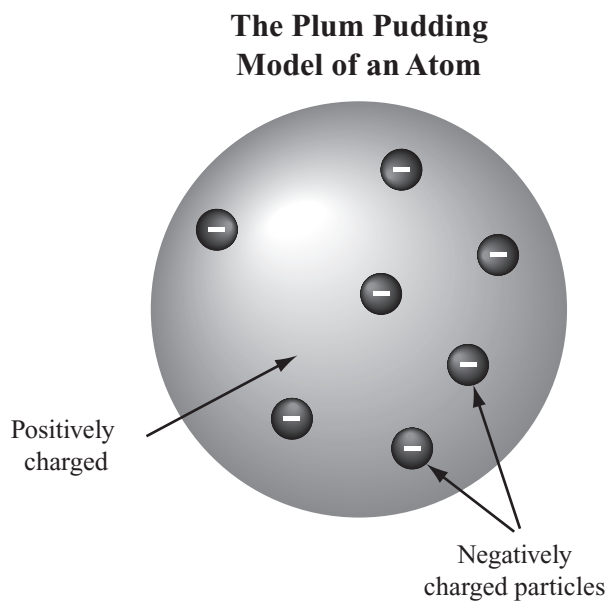

Compare a currently accepted model of the atom with this plum pudding model. Include information about (1) the types of particles, (2) their charges, and (3) their locations for each model.

Write your answer to question 26 in the space provided in your Student Answer Booklet.

26 Magnesium oxide, $\text{MgO}(s)$, is an ionic compound. Water, $\text{H}_2\text{O}(l)$, is a covalent compound.

a. Explain how atoms are held together in both ionic and covalent compounds.

The bonding of atoms in a compound usually makes them more stable than atoms that exist by themselves.

b. Choose one of the given compounds, $\text{MgO}(s)$ or $\text{H}_2\text{O}(l)$, and explain in detail how its atoms bond to form a stable compound. You may use a diagram in your response.

Chemistry

SESSION 2

DIRECTIONS

This session contains seventeen multiple-choice questions and two open-response questions. Mark your answers to these questions in the spaces provided in your Student Answer Booklet. You may work out solutions to multiple-choice questions in the test booklet.

- 27 Which of the following explains why saltwater is considered a mixture?
- A. It is composed of one element.
 - B. It is composed of one compound.
 - C. It is composed of two or more substances and has new chemical properties.
 - D. It is composed of two or more substances that retain their own chemical properties.

- 28 The table below contains a list of properties for an unidentified element, X.

Physical Characteristics	Very soft with silvery-white luster when cut
Reactivity	Ignites in air and reacts violently with cold H_2O
Some Common Compounds	XCl , X_2SO_4 , X_3PO_4 , XOH , X_2O
Melting Point (°C)	39.1
Boiling Point (°C)	688

Based on the properties in the table, to which of the following groups from the periodic table does element X **most likely** belong?

- A. 1 (1A)
- B. 2 (2A)
- C. 14 (4A)
- D. 16 (6A)

- 29 Ernest Rutherford performed an experiment in which he shot alpha particles through a thin layer of gold foil. He predicted that the alpha particles would travel straight through the gold atoms, as shown below.

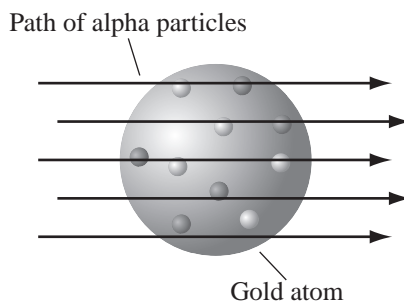

However, Rutherford observed that although most of the alpha particles passed straight through the foil, a few alpha particles were deflected, as shown below.

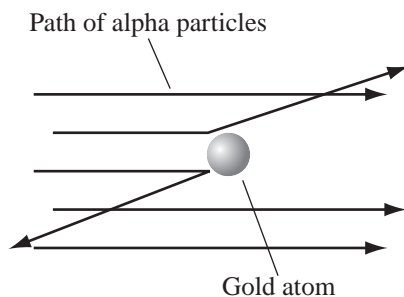

Which of the following statements about the atom did Rutherford's experiment support?

- A. An atom contains protons, neutrons, and electrons.
- B. An atom's nucleus is small and has a positive charge.
- C. Electrons follow a predictable path around the nucleus.
- D. Different isotopes of an element have different masses.

30 Which of the following chemical equations is balanced correctly?

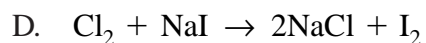
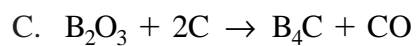
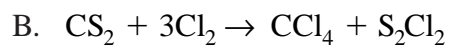
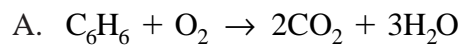

31 Under certain conditions, solid magnesium (Mg) and solid sulfur (S) can combine and form magnesium sulfide (MgS). The oxidation-reduction reaction is shown below.

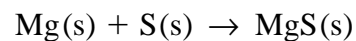

Which of the following is the oxidation number for Mg in MgS in this reaction?

A. +1

B. -1

C. +2

D. -2

Question 32 is an open-response question.

- **BE SURE TO ANSWER AND LABEL ALL PARTS OF THE QUESTION.**
- **Show all your work (diagrams, tables, or computations) in your Student Answer Booklet.**
- **If you do the work in your head, explain in writing how you did the work.**

Write your answer to question 32 in the space provided in your Student Answer Booklet.

- 32 The equation below represents the reaction of water and oxygen to produce hydrogen peroxide (H_2O_2). The equation shows the reaction to be at equilibrium.

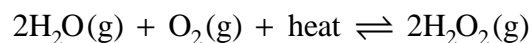

Describe **two** ways to shift the equilibrium to the right in order to increase the amount of H_2O_2 produced. Explain your reasoning.

Mark your answers to multiple-choice questions 33 through 38 in the spaces provided in your Student Answer Booklet. Do not write your answers in this test booklet, but you may work out solutions to multiple-choice questions in the test booklet.

33 Which of the following is the formula for ammonium hydroxide?

- A. Al_2O_3
- B. AmO_2
- C. NH_3OH
- D. NH_4OH

34 A student adds 68.4 g of sucrose ($\text{C}_{12}\text{H}_{22}\text{O}_{11}$) to 750 mL of 20°C water. She stirs the solution until all of the sucrose crystals dissolve. She then transfers the solution to a volumetric flask and fills it to the 1.00 L mark with 20°C water.

What is the molarity of the sucrose solution the student prepared?

- A. 0.20 M
- B. 0.70 M
- C. 1.0 M
- D. 6.8 M

35 The table below shows some characteristics of four substances at 1 atm pressure.

Substance	Color	Melting Point ($^\circ\text{C}$)	Boiling Point ($^\circ\text{C}$)
Bromine	red-brown	-7	59
Chlorine	green-yellow	-101	-34
Ethanol	colorless	-117	78
Mercury	silver-white	-39	357

Which of the following substances is a liquid at temperatures ranging from -50°C to 0°C ?

- A. bromine
- B. chlorine
- C. ethanol
- D. mercury

- 36 In the following diagrams, the spheres represent particles. Different shadings represent different particles.

Which of the following contains only one pure substance?

A.

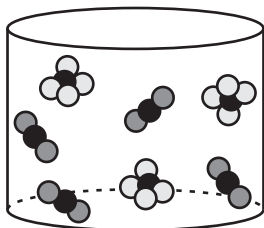

B.

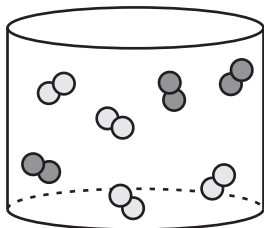

C.

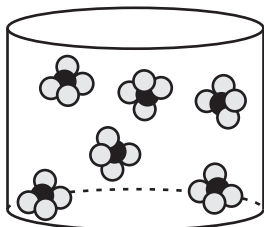

D.

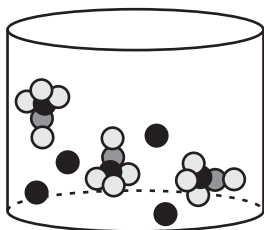

- 37 Nuclear fusion occurs in the core of a star when deuterium and tritium react. The equation below represents this fusion reaction.

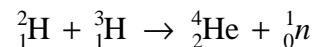

Which of the following **best** explains why a large amount of energy is released in this reaction?

- A. The hydrogen converts the light into energy.
- B. Some of the reactant mass is converted into energy.
- C. All of the hydrogen isotopes undergo radioactive decay.
- D. The temperature of the products is lower than that of the reactants.
- 38 An unknown metal, X, combines with nitrogen to form the compound XN. Metal X also combines with oxygen to produce the compound X₂O₃. Metal X is **most likely** which of the following elements?
- A. ${}^3\text{Li}$
- B. ${}^{12}\text{Mg}$
- C. ${}^{31}\text{Ga}$
- D. ${}^{50}\text{Sn}$

Question 39 is an open-response question.

- **BE SURE TO ANSWER AND LABEL ALL PARTS OF THE QUESTION.**
- **Show all your work (diagrams, tables, or computations) in your Student Answer Booklet.**
- **If you do the work in your head, explain in writing how you did the work.**

Write your answer to question 39 in the space provided in your Student Answer Booklet.

- 39 Propane (C_3H_8) burns in oxygen to produce carbon dioxide and water.
- Write a balanced chemical equation for this reaction.
 - If 11.0 g of propane gas is burned completely, 33.0 g of carbon dioxide and 18.0 g of water are produced. Determine the mass of oxygen consumed. Show your calculations and include units in your answer.

Mark your answers to multiple-choice questions 40 through 45 in the spaces provided in your Student Answer Booklet. Do not write your answers in this test booklet, but you may work out solutions to multiple-choice questions in the test booklet.

- 40 A 1.00 kg sample of water (H_2O) contains 0.11 kg of hydrogen (H) and 0.89 kg of oxygen (O). According to the law of constant composition, how much hydrogen and oxygen would a 1.5 kg sample of water contain?
- A. 0.11 kg H and 0.89 kg O
 - B. 0.17 kg H and 1.34 kg O
 - C. 0.22 kg H and 1.78 kg O
 - D. 1.34 kg H and 0.17 kg O
- 41 When stirred in 30°C water, 5 g of powdered potassium bromide, KBr, dissolves faster than 5 g of large crystals of potassium bromide. Which of the following best explains why the powdered KBr dissolves faster?
- A. Powdered potassium bromide exposes more surface area to water molecules than large crystals of potassium bromide.
 - B. Potassium ions and bromide ions in the powder are smaller than potassium ions and bromide ions in the large crystals.
 - C. Fewer potassium ions and bromide ions have been separated from each other in the powder than in the crystals.
 - D. Powdered potassium bromide is less dense than large crystals of potassium bromide.

- 42 Which of the following is an example of a physical change?
- A. Iron exposed to air produces rust.
 - B. Hydrogen combined with oxygen forms water.
 - C. Sulfur combined with oxygen produces sulfur dioxide.
 - D. Liquid nitrogen exposed to air becomes nitrogen gas.
- 43 Which of the following trends in the periodic table should be expected as the atomic number of the halogens increases from fluorine (F) to iodine (I)?
- A. Atomic radius decreases.
 - B. Electronegativity decreases.
 - C. Atomic mass decreases.
 - D. Electron number decreases.
- 44 Which of the following statements describes the elements in family 16 of the periodic table?
- A. They have six valence electrons.
 - B. They are all gases at room temperature.
 - C. They exist commonly as cations in nature.
 - D. They combine easily with elements in family 17.
- 45 What is the volume of one mole of hydrogen gas (H_2) at standard temperature and pressure (STP)?
- A. 1.0 L
 - B. 2.0 L
 - C. 22.4 L
 - D. 44.8 L

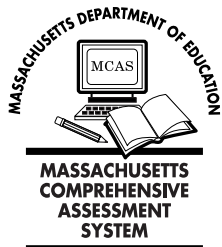

Massachusetts Comprehensive Assessment System

Chemistry Formula and Constants Sheet

Common Polyatomic Ions

Ion	Ionic Formula
Ammonium	NH_4^+
Carbonate	CO_3^{2-}
Hydroxide	OH^-
Nitrate	NO_3^-
Phosphate	PO_4^{3-}
Sulfate	SO_4^{2-}

Combined Gas Law:
$$\frac{P_1 V_1}{T_1} = \frac{P_2 V_2}{T_2}$$

Ideal Gas Law: $PV = nRT$

Absolute Temperature Conversion: $K = ^\circ\text{C} + 273$

Moles of Solute: $M_1 V_1 = M_2 V_2$

Definition of pH: $\text{pH} = -\log [\text{H}_3\text{O}^+] = -\log [\text{H}^+]$

Molar Volume of Ideal Gas at STP: 22.4 L/mol

Ideal Gas Constant: $R = 0.0821 \text{ L} \cdot \text{atm/mol} \cdot \text{K} = 8.31 \text{ L} \cdot \text{kPa/mol} \cdot \text{K}$

Avogadro's Number: 6.02×10^{23} particles/mol

STP: 1 atm (101.3 kPa), 273 K (0°C)

Nuclear Symbols

Name	Symbol
Alpha particle	α or ${}^4_2\text{He}$
Beta particle	β or ${}^0_{-1}e$
Gamma ray	γ
Neutron	1_0n



Massachusetts Comprehensive Assessment System

Periodic Table of the Elements

Period	Group (Family)																		
	1A	2A	8B										3A	4A	5A	6A	7A	8A	
	1	2	3	4	5B	6B	7B	8	9	10	11	12	13	14	15	16	17	18	
1	1.00794 H 1 Hydrogen		9.01218 Li 3 Lithium	4.00260 He 2 Helium															
2	22.98977 Na 11 Sodium	24.305 Mg 12 Magnesium	44.9559 Sc 21 Scandium	47.88 Ti 22 Titanium	50.9415 V 23 Vanadium	51.996 Cr 24 Chromium	54.9380 Mn 25 Manganese	55.847 Fe 26 Iron	58.9332 Co 27 Cobalt	58.69 Ni 28 Nickel	63.546 Cu 29 Copper	65.39 Zn 30 Zinc	10.81 B 5 Boron	12.0111 C 6 Carbon	14.0067 N 7 Nitrogen	15.9994 O 8 Oxygen	18.998403 F 9 Fluorine	20.179 Ne 10 Neon	
3	39.0983 K 19 Potassium	40.08 Ca 20 Calcium	88.9059 Y 39 Yttrium	91.224 Zr 40 Zirconium	92.9064 Nb 41 Niobium	95.94 Mo 42 Molybdenum	98 Tc 43 Technetium	101.07 Ru 44 Ruthenium	102.906 Rh 45 Rhodium	106.42 Pd 46 Palladium	107.868 Ag 47 Silver	112.41 Cd 48 Cadmium	26.98154 Al 13 Aluminum	28.0855 Si 14 Silicon	30.97376 P 15 Phosphorus	32.06 S 16 Sulfur	35.453 Cl 17 Chlorine	39.948 Ar 18 Argon	
4	85.4678 Rb 37 Rubidium	87.62 Sr 38 Strontium	88.9059 Scandium	91.224 Titanium	92.9064 Niobium	95.94 Molybdenum	98 Technetium	101.07 Ruthenium	102.906 Rhodium	106.42 Palladium	107.868 Silver	112.41 Cadmium	69.72 Ga 31 Gallium	72.59 Ge 32 Germanium	74.9216 As 33 Arsenic	78.96 Se 34 Selenium	79.904 Br 35 Bromine	83.80 Kr 36 Krypton	
5	132.905 Cs 55 Cesium	137.33 Ba 56 Barium	138.906 La 57 Lanthanum	178.49 Hf 72 Hafnium	180.948 Ta 73 Tantalum	183.85 W 74 Tungsten	186.207 Re 75 Rhenium	190.2 Os 76 Osmium	192.22 Ir 77 Iridium	195.08 Pt 78 Platinum	196.967 Au 79 Gold	200.59 Hg 80 Mercury	114.82 In 49 Indium	118.71 Sn 50 Tin	121.75 Sb 51 Antimony	127.60 Te 52 Tellurium	126.905 I 53 Iodine	131.29 Xe 54 Xenon	
6	(223) Fr 87 Francium	226.025 Ra 88 Radium	227.028 Ac 89 Actinium	(261) Rf* 104 Rutherfordium	(262) Db 105 Dubnium	(263) Sg 106 Seaborgium	(265) Hs 108 Hassium	(266) Mt 109 Meitnerium	(268?) Lr 103 Lawrencium	207.2 Pb 82 Lead	208.980 Bi 83 Bismuth	209 Po 84 Polonium	114.82 In 49 Indium	118.71 Sn 50 Tin	121.75 Sb 51 Antimony	127.60 Te 52 Tellurium	126.905 I 53 Iodine	(222) Rn 86 Radon	
7													113 B 5 Boron	114 C 6 Carbon	115 N 7 Nitrogen	116 O 8 Oxygen	117 F 9 Fluorine	118 Ne 10 Neon	

Mass numbers in parentheses are those of the most stable or most common isotope.

Lanthanide Series

Actinide Series

High School Chemistry
Spring 2007 Released Items:
Reporting Categories, Standards, and Correct Answers

Item No.	Page No.	Reporting Category	Standard	Correct Answer (MC)*
1	487	<i>Bonding and Reactions</i>	4.2	A
2	487	<i>Bonding and Reactions</i>	5.4	B
3	487	<i>Atomic Structure and Periodicity</i>	2.4	C
4	487	<i>Bonding and Reactions</i>	5.3	B
5	488	<i>Properties of Matter and Thermochemistry</i>	6.3	C
6	488	<i>Bonding and Reactions</i>	5.5	C
7	489	<i>Solutions, Equilibrium, and Acid-Base Theory</i>	7.3	A
8	489	<i>Atomic Structure and Periodicity</i>	2.6	A
9	490	<i>Properties of Matter and Thermochemistry</i>	6.1	A
10	490	<i>Solutions, Equilibrium, and Acid-Base Theory</i>	7.1	D
11	491	<i>Properties of Matter and Thermochemistry</i>	1.3	
12	492	<i>Atomic Structure and Periodicity</i>	3.1	B
13	492	<i>Properties of Matter and Thermochemistry</i>	1.1	B
14	492	<i>Bonding and Reactions</i>	5.4	C
15	492	<i>Properties of Matter and Thermochemistry</i>	6.3	C
16	493	<i>Bonding and Reactions</i>	5.2	A
17	493	<i>Properties of Matter and Thermochemistry</i>	6.2	D
18	493	<i>Solutions, Equilibrium, and Acid-Base Theory</i>	8.1	A
19	494	<i>Bonding and Reactions</i>	5.3	C
20	494	<i>Solutions, Equilibrium, and Acid-Base Theory</i>	8.2	A
21	495	<i>Solutions, Equilibrium, and Acid-Base Theory</i>	7.6	A
22	495	<i>Atomic Structure and Periodicity</i>	2.5	D
23	495	<i>Properties of Matter and Thermochemistry</i>	1.3	C
24	495	<i>Atomic Structure and Periodicity</i>	3.2	A
25	496	<i>Atomic Structure and Periodicity</i>	2.1	
26	497	<i>Bonding and Reactions</i>	4.1	
27	498	<i>Properties of Matter and Thermochemistry</i>	1.2	D
28	498	<i>Atomic Structure and Periodicity</i>	3.1	A
29	499	<i>Atomic Structure and Periodicity</i>	2.2	B
30	500	<i>Bonding and Reactions</i>	5.1	B
31	500	<i>Bonding and Reactions</i>	8.4	C
32	501	<i>Solutions, Equilibrium, and Acid-Base Theory</i>	7.6	
33	502	<i>Bonding and Reactions</i>	4.6	D
34	502	<i>Solutions, Equilibrium, and Acid-Base Theory</i>	7.2	A
35	502	<i>Properties of Matter and Thermochemistry</i>	1.3	C
36	503	<i>Properties of Matter and Thermochemistry</i>	1.2	C
37	503	<i>Atomic Structure and Periodicity</i>	2.7	B
38	503	<i>Bonding and Reactions</i>	4.1	C
39	504	<i>Bonding and Reactions</i>	5.1	
40	505	<i>Atomic Structure and Periodicity</i>	2.3	B
41	505	<i>Solutions, Equilibrium, and Acid-Base Theory</i>	7.3	A
42	506	<i>Properties of Matter and Thermochemistry</i>	1.1	D

Item No.	Page No.	Reporting Category	Standard	Correct Answer (MC)*
43	506	<i>Atomic Structure and Periodicity</i>	3.4	B
44	506	<i>Atomic Structure and Periodicity</i>	3.1	A
45	506	<i>Properties of Matter and Thermochemistry</i>	6.2	C

* Answers are provided here for multiple-choice items only. Sample responses and scoring guidelines for open-response items, which are indicated by shaded cells, will be posted to the Department's Web site later this year.

XX. Introductory Physics, High School

High School Introductory Physics Test

The spring 2007 high school MCAS Introductory Physics test was based on learning standards in the Physics content strand of the Massachusetts *Science and Technology/Engineering Curriculum Framework* (2006). These learning standards appear on pages 74–77 of the *Framework*.

The *Science and Technology/Engineering Curriculum Framework* is available on the Department Web site at www.doe.mass.edu/frameworks/current.html.

In *Test Item Analysis Reports* and on the Subject Area Subscore pages of the MCAS *School Reports* and *District Reports*, Introductory Physics test results are reported under the following four MCAS reporting categories:

- Motion and Forces
- Heat and Heat Transfer
- Waves and Radiation
- Electromagnetism

Test Sessions

The MCAS high school Introductory Physics test included two separate test sessions, which were administered on consecutive days. Each session included multiple-choice and open-response questions.

Reference Materials and Tools

Each student taking the high school Introductory Physics test was provided with a Physics Formula Sheet. A copy of this formula sheet follows the final question in this chapter.

Each student also had sole access to a calculator with at least four functions and a square-root key.

The use of bilingual word-to-word dictionaries was allowed for current and former limited English proficient students only, during both Introductory Physics test sessions. No other reference tools or materials were allowed.

Cross-Reference Information

The table at the conclusion of this chapter indicates each item's reporting category and the *Framework* learning standard it assesses. The correct answers for multiple-choice questions are also displayed in the table.

Introductory Physics

SESSION 1

DIRECTIONS

This session contains twenty-three multiple-choice questions and three open-response questions. Mark your answers to these questions in the spaces provided in your Student Answer Booklet. You may work out solutions to multiple-choice questions in the test booklet.

- 1 A car is parked on the side of a hill. Which of the following **most likely** prevents the car from moving down the hill?
- A. The car has too much mass to move easily.
 - B. There is friction in the door hinges of the car.
 - C. There is friction between the tires and the road.
 - D. The weight of the car is mostly on the front wheels.

- 2 Thermal energy is added to four identical 1.0 kg samples of water at room temperature. Which of the following increases in each sample?
- A. average charge of an electron
 - B. average density of a nucleus
 - C. average mass of a proton
 - D. average speed of a molecule

- 3 A current of 2 A passes through two resistors placed in series. The first resistor has a resistance of $10\ \Omega$ and the second resistor has a resistance of $20\ \Omega$. What is the total potential difference across the two resistors?
- A. 13 V
 - B. 15 V
 - C. 30 V
 - D. 60 V

- 4 The diagram below shows a wave generator that emits a wave with a frequency of 500 Hz and a wavelength of 0.1 m.

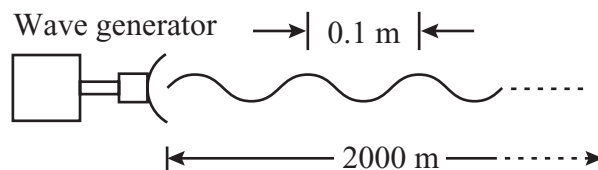

- How long does it take for the wave to travel a distance of 2000 m?
- A. 20 s
 - B. 30 s
 - C. 40 s
 - D. 50 s

5 A hockey player swings her hockey stick and strikes a puck. According to Newton’s third law of motion, which of the following is a reaction to the stick pushing on the puck?

- A. the puck pushing on the stick
- B. the stick pushing on the player
- C. the player pushing on the stick
- D. the puck pushing on the player

6 To make ice, water must first be cooled. The specific heat of water is $4,186 \text{ J/kg} \cdot ^\circ\text{C}$.

Approximately how much heat must be removed from 0.50 kg of water to change its temperature from 24°C to 5°C ?

- A. 0 J
- B. 19,900 J
- C. 39,800 J
- D. 79,500 J

7 The diagrams below show a cart moving with a velocity, V , on a frictionless surface as a wooden block is being dropped. The block then falls straight down onto the moving cart.

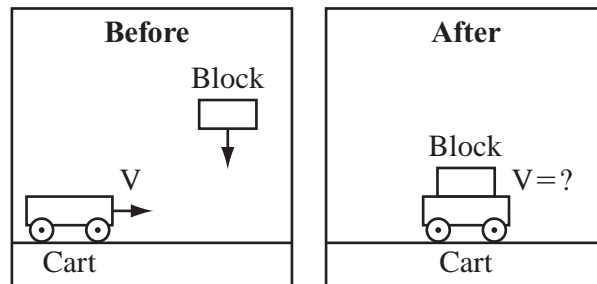

Which of the following statements describes what will happen after the block lands on the moving cart?

- A. The cart will move to the left at a velocity less than the original velocity of the cart.
- B. The cart will move to the left at a velocity greater than the original velocity of the cart.
- C. The cart will move to the right at a velocity less than the original velocity of the cart.
- D. The cart will move to the right at a velocity greater than the original velocity of the cart.

- 8 A cart at the top of a hill is released and rolls down the hill. Which of the following describes the energy of the cart just as it reaches the bottom of the hill?
- A. The cart has no energy.
 - B. The cart has maximum kinetic energy.
 - C. The cart has maximum gravitational potential energy.
 - D. The cart has equal gravitational potential and kinetic energy.
- 9 When one end of a short metal bar is heated, the opposite end will eventually become hot. Which of the following processes transfers the heat through the bar?
- A. condensation
 - B. conduction
 - C. convection
 - D. radiation
- 10 Which of the following will definitely cause a change in the velocity of a parked car?
- A. The car experiences an unbalanced force.
 - B. All forces acting on the car increase by 1 N.
 - C. All forces acting on the car decrease by 1 N.
 - D. The forces acting on the car are equal and balanced.

Question 11 is an open-response question.

- **BE SURE TO ANSWER AND LABEL ALL PARTS OF THE QUESTION.**
- **Show all your work (diagrams, tables, or computations) in your Student Answer Booklet.**
- **If you do the work in your head, explain in writing how you did the work.**

Write your answer to question 11 in the space provided in your Student Answer Booklet.

11 A student rubs a balloon on her hair and the balloon acquires a negative charge.

- Explain why the balloon acquires a negative charge.
- After the balloon is rubbed on the student's head, the student's hair stands out from her head. Explain why this happens.

The student then brings the negatively charged balloon near another balloon that was charged in the same way.

- Describe and explain what happens when the negatively charged balloon is brought near another negatively charged balloon.

Mark your answers to multiple-choice questions 12 through 24 in the spaces provided in your Student Answer Booklet. Do not write your answers in this test booklet, but you may work out solutions to multiple-choice questions in the test booklet.

- 12 A rise in the temperature inside a kitchen means there is an increase in the
- A. density of the air molecules.
 - B. number of the air molecules.
 - C. average size of the air molecules.
 - D. average kinetic energy of the air molecules.
- 13 Which of the following provides the **best** example of simple harmonic motion?
- A. riding a regular bus route
 - B. sliding down a water slide
 - C. running a consistent daily jog
 - D. swinging on a playground swing
- 14 Jessica places 1000 g of water at 20.0°C in an insulated cup. The specific heat capacity of water is $4.20 \text{ J/g} \cdot ^{\circ}\text{C}$. What is the final temperature of the water if 5000 J of energy is added to the water in the insulated cup?
- A. 20.1°C
 - B. 20.5°C
 - C. 21.2°C
 - D. 25.0°C
- 15 Which of the following is a vector quantity?
- A. mass
 - B. force
 - C. temperature
 - D. kinetic energy

- 16 Two identical beakers each contain 250 mL of water. The temperature of the water is 85°C in one beaker and 15°C in the other beaker. A drop of red food coloring is placed in each beaker at the same time.

During the first minute, which of the following is **most likely** to happen?

- A. The food coloring will spread out faster in the 85°C water than in the 15°C water.
- B. The food coloring will form a layer at the top of each beaker since it does not mix with water.
- C. The food coloring will spread only halfway through the water in each beaker due to convection currents.
- D. The food coloring will settle faster at the bottom of the beaker containing 85°C water than at the bottom of the beaker containing 15°C water.

- 17 The graph below relates the current to voltage data for a resistor.

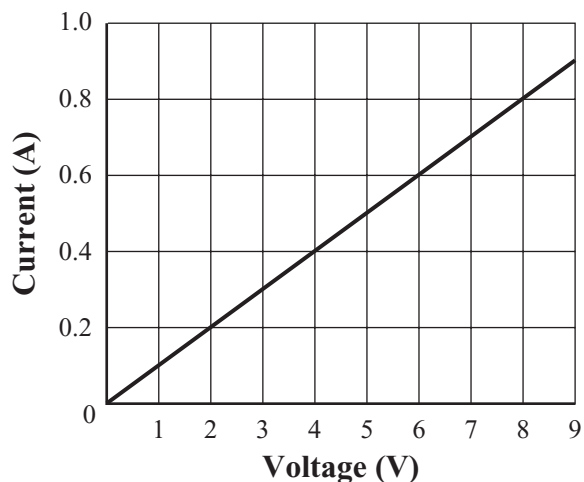

Which of the following is the value of the resistor?

- A. 0.2 Ω
- B. 2 Ω
- C. 4 Ω
- D. 10 Ω

- 18 The illustration below shows wave traces of recorded sound waves on two computer screens.

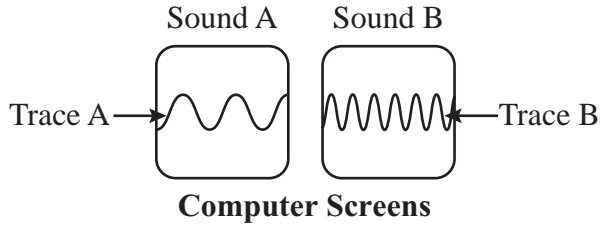

Traces A and B represent two different sounds with the same time scale horizontally.

From a comparison of the wave traces, which of the following **correctly** describes the relationship of sound B to sound A?

- A. Sound B has a higher velocity.
- B. Sound B has a higher amplitude.
- C. Sound B has a higher frequency.
- D. Sound B has a longer wavelength.

- 19 What is the mass of an object weighing 63 N on Earth?

- A. 0.1 kg
- B. 6.3 kg
- C. 73 kg
- D. 617 kg

- 20 Which of the following is **least likely** to result in the generation of static charge?
- A. peeling plastic wrap off a CD case
 - B. combing dry hair with a plastic comb
 - C. rubbing one's shoes on a synthetic carpet
 - D. drying one's body with a towel after a shower

- 21 The two resistors shown below are connected to identical power sources. Resistor 1 has a resistance of $30\ \Omega$, and resistor 2 has a resistance of $45\ \Omega$. The current in resistor 1 is $2\ \text{A}$.

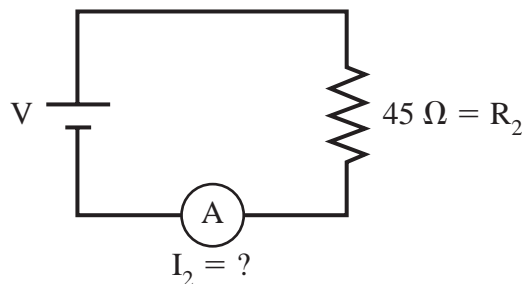
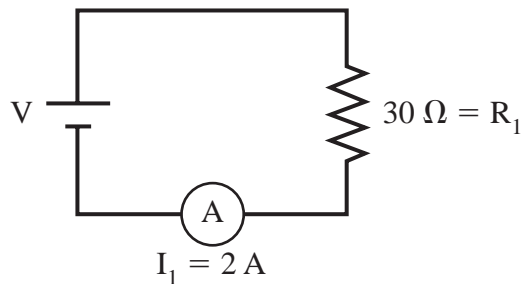

What is the current in resistor 2?

- A. $1.0\ \text{A}$
- B. $1.3\ \text{A}$
- C. $1.5\ \text{A}$
- D. $3.0\ \text{A}$

- 22 The distance between Earth and the Moon was determined by measuring the time it took for light waves from Earth to travel to the Moon and back. Why was it **not** possible to use sound waves for this experiment?
- A. Sound waves must move through a substance.
 - B. Sound waves would change frequency on the return to Earth.
 - C. Sound waves move too slowly for the technique to be accurate.
 - D. Sound waves move more slowly in Earth's atmosphere than in space.
- 23 Which of the following requires the greatest amount of heat?
- A. increasing the temperature of 1 kg of water from 0°C to 30°C
 - B. increasing the temperature of 10 kg of water from 10°C to 20°C
 - C. increasing the temperature of 20 kg of water from 19°C to 21°C
 - D. increasing the temperature of 50 kg of water from 20°C to 21°C
- 24 If heat is added to a liquid, which of the following occurs?
- A. The friction in the liquid increases.
 - B. The size of the liquid molecules expands.
 - C. The potential energy of the liquid changes.
 - D. The molecular motion in the liquid increases.

Questions 25 and 26 are open-response questions.

- **BE SURE TO ANSWER AND LABEL ALL PARTS OF EACH QUESTION.**
- **Show all your work (diagrams, tables, or computations) in your Student Answer Booklet.**
- **If you do the work in your head, explain in writing how you did the work.**

Write your answer to question 25 in the space provided in your Student Answer Booklet.

- 25 On a smooth, level surface, a red marble of mass 0.02 kg moving at 2.0 m/s collides with a stationary yellow marble of equal mass. After the collision, the red marble stops completely, and the yellow marble moves in the direction the red marble was moving.
- a. Calculate the momentum of both marbles before the collision. Show your calculations and include units in your answer.
 - b. Calculate the momentum of both marbles after the collision. Show your calculations and include units in your answer.
 - c. If the velocity of the red marble doubles, how will the velocity of the yellow marble change after the collision?
 - d. If the red marble had **more** mass than the yellow marble, how would the momentum of the yellow marble change after the collision?

Write your answer to question 26 in the space provided in your Student Answer Booklet.

- 26 The drawing below shows two students holding the ends of a spring that has a ribbon attached to it.

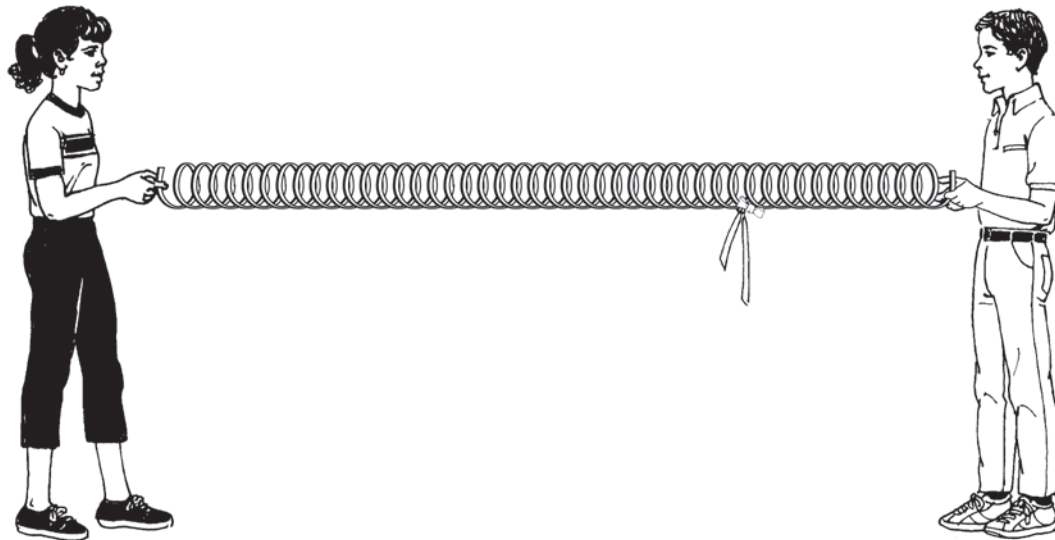

In your Student Answer Booklet:

- Draw and explain how a transverse wave will move along the spring.
- Draw and explain how the ribbon will move when a transverse wave is sent along the spring.
- Draw and explain how a longitudinal wave will move along the spring.
- Draw and explain how the ribbon will move when a longitudinal wave is sent along the spring.

Introductory Physics

SESSION 2

DIRECTIONS

This session contains seventeen multiple-choice questions and two open-response questions. Mark your answers to these questions in the spaces provided in your Student Answer Booklet. You may work out solutions to multiple-choice questions in the test booklet.

- 27 A 600 g basketball, a 57 g tennis ball, a 46 g golf ball, and a 2.7 g table tennis ball are moving with the same velocity. Which ball has the **greatest** momentum?

A. golf ball
B. basketball
C. tennis ball
D. table tennis ball

- 28 Which of the following is a **main** factor that affects the speed of a wave?

A. the pitch of sound
B. the loudness of sound
C. the amplitude of the wave
D. the properties of the medium

- 29 Which of the following graphs **best** represents the relationship of the frequency of an electromagnetic wave to its wavelength?

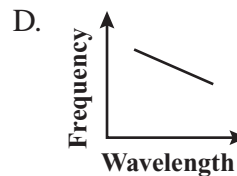
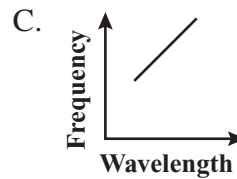
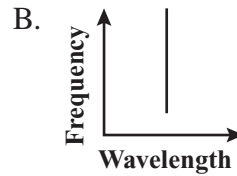
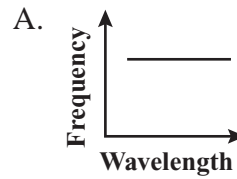

- 30 The motor of one car is more powerful than the motor of another car. Which of the following must be true of the more powerful motor?
- A. It can do work more quickly.
 - B. It can operate for a longer time.
 - C. It can burn fuel more efficiently.
 - D. It can store more potential energy.
- 31 Which of the following waves travels **fastest**?
- A. water waves in oceans
 - B. seismic waves in rocks
 - C. sound waves from a violin string
 - D. electromagnetic waves from the Sun

Question 32 is an open-response question.

- **BE SURE TO ANSWER AND LABEL ALL PARTS OF THE QUESTION.**
- **Show all your work (diagrams, tables, or computations) in your Student Answer Booklet.**
- **If you do the work in your head, explain in writing how you did the work.**

Write your answer to question 32 in the space provided in your Student Answer Booklet.

- 32 In an experiment, the current is varied as it goes through the resistor in a circuit. An ammeter measures the current going through the resistor and a voltmeter measures the voltage across the resistor. The data are recorded and shown below.

Circuit Data

Current (A)	Voltage (V)
0.20	1.5
0.40	3.0
0.80	6.0
1.20	9.0
1.60	12.0
2.80	21.0

- Using the data in the table, make a graph of the voltage versus the current in the circuit. Voltage should be on the y -axis. Make sure the graph has clearly labeled axes and a proper scale.
- Find the slope of the graphed line. Show your calculations and include units in your answer.
- Explain what the slope represents.

Mark your answers to multiple-choice questions 33 through 38 in the spaces provided in your Student Answer Booklet. Do not write your answers in this test booklet, but you may work out solutions to multiple-choice questions in the test booklet.

- 33 The diagram below shows a hammer about to strike a moveable piston.

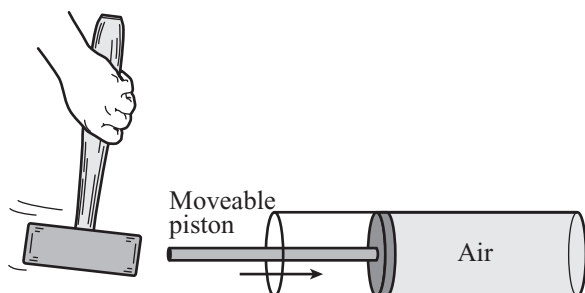

As the piston moves suddenly when struck, which type of wave pulse is generated in the air inside the cylinder?

- A. electromagnetic
 - B. transverse
 - C. refracted
 - D. longitudinal
- 34 How long will it take a car to accelerate from 20 m/s to 26 m/s at a rate of 1.4 m/s^2 ?
- A. 2.2 s
 - B. 2.7 s
 - C. 4.3 s
 - D. 4.6 s

- 35 Which of the following can carry light waves but not sound waves?

- A. air
- B. steel
- C. water
- D. vacuum

- 36 A crane lifts two 100 kg loads of building materials to the top of a building under construction. The first load is lifted in 10 s and the second load is lifted in 13 s.

Which of the following statements **best** compares the work and power expended by the crane lifting the two loads?

- A. The crane does more work and expends more power for the first lift.
- B. The crane does the same work and expends the same power for each lift.
- C. The crane does the same work for each lift but expends more power for the first lift.
- D. The crane does more work in the second lift but expends the same power for each lift.

- 37 The graph below relates velocity to time.

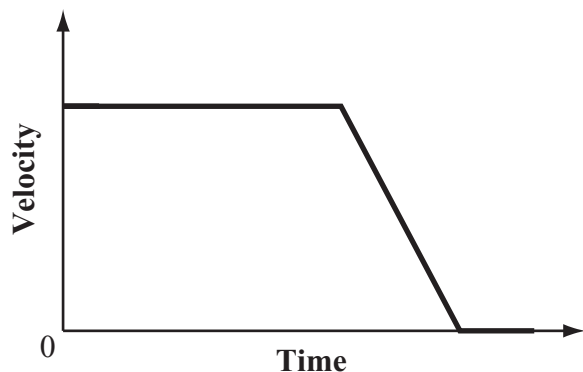

The graph would **most likely** apply to which of the following events?

- A. A soccer ball that is at rest is suddenly kicked.
- B. A ball is thrown upward and returns to the ground.
- C. A person who is running at a constant speed decides to run faster.
- D. A car traveling at a constant speed applies its brakes and comes to a stop.

- 38 Which of the following waves can travel at a speed of 3×10^8 m/s ?

- A. microwaves
- B. seismic waves
- C. ultrasonic waves
- D. water waves

Question 39 is an open-response question.

- **BE SURE TO ANSWER AND LABEL ALL PARTS OF THE QUESTION.**
- **Show all your work (diagrams, tables, or computations) in your Student Answer Booklet.**
- **If you do the work in your head, explain in writing how you did the work.**

Write your answer to question 39 in the space provided in your Student Answer Booklet.

- 39** A book is on a table. A student pushes it for a short time. Initially the book moves, but then it comes to a complete stop.
- Identify the forces acting on the book before it is pushed. You may include a labeled diagram in your answer.
 - Explain why the book moves and then comes to a complete stop. Use the laws of physics in your answer.
 - The student wants the book to move at a constant speed in one direction. Describe the physical conditions needed for this to occur.

Mark your answers to multiple-choice questions 40 through 45 in the spaces provided in your Student Answer Booklet. Do not write your answers in this test booklet, but you may work out solutions to multiple-choice questions in the test booklet.

- 40 The diagram below shows an electrical circuit.

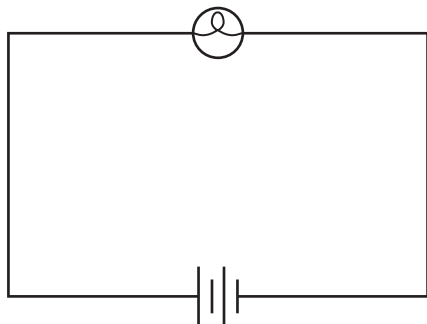

Which of the following **best** explains why energy stored in the battery power source diminishes over time when this circuit is complete?

- A. Energy is destroyed when the light bulb operates.
- B. The light bulb transforms energy into light and heat.
- C. The light bulb converts the negative charge of electrons into light and heat.
- D. The power source generates energy more slowly than the light bulb consumes it.

- 41 A 9 kg model airplane flies horizontally at a constant speed. If the plane suddenly dives from its altitude of 50 m and levels off at 20 m, how much potential energy does it lose in the dive?

- A. 450 J
- B. 1800 J
- C. 2700 J
- D. 9000 J

- 42 Ultraviolet light has a shorter wavelength than visible light. Which of the following is another way ultraviolet light can be compared to visible light?

- A. Ultraviolet light has a lower frequency than visible light.
- B. Ultraviolet light has a higher frequency than visible light.
- C. Ultraviolet light travels faster than visible light.
- D. Ultraviolet light travels slower than visible light.

43 To calculate the momentum of a pickup truck with a velocity of 25 m/s east, it is also necessary to know which of the following?

- A. time elapsed
- B. drive force of the motor
- C. mass of the pickup truck
- D. distance that the pickup travels

44 The diagram below represents two identical space ships, Earth, a space station, and the Moon.

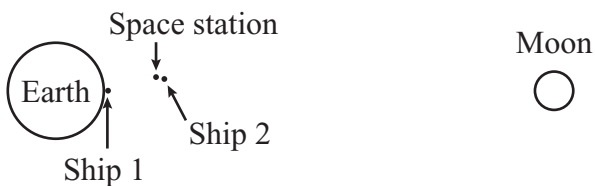

The two ships are launched toward the Moon. Ship 1 is launched from Earth, and ship 2 is launched from the space station. It takes less force to launch ship 2.

Which of the following contributes **most** to the difference in the forces?

- A. Ship 2 has less inertia in space than ship 1 does on Earth.
- B. Earth exerts less gravitational force on ship 2 than on ship 1.
- C. Ship 2 must travel a shorter distance than ship 1 before reaching the Moon.
- D. The Moon exerts more gravitational force on ship 2 than on ship 1.

45 A sealed glass container holds molecules of nitrogen gas. The nitrogen molecules have increasing velocities.

Which of the following will make the molecules move faster?

- A. bonding the molecules together
- B. transferring heat to the molecules
- C. expanding the volume of the container
- D. decreasing the pressure in the container



Massachusetts Comprehensive Assessment System

Introductory Physics Formula Sheet

Formulas

$$\text{Average Speed} = \frac{\Delta d}{\Delta t}$$

$$F = G \frac{m_1 m_2}{d^2}$$

$$p = mv$$

$$\text{Average Acceleration} = \frac{\Delta v}{\Delta t}$$

$$F = k \frac{q_1 q_2}{d^2}$$

$$V = IR$$

$$\text{Average Velocity} = \frac{v_i + v_f}{2}$$

$$KE = \frac{1}{2}mv^2$$

$$P = IV$$

$$v_f = v_i + a\Delta t$$

$$PE = mg\Delta h$$

$$Q = mc\Delta T$$

$$\Delta d = v_i \Delta t + \frac{1}{2}a(\Delta t)^2$$

$$W = F\Delta d$$

$$v = f\lambda$$

$$v_f^2 = v_i^2 + 2a\Delta d$$

$$P = \frac{W}{\Delta t}$$

$$\lambda = \frac{c}{f}$$

$$F = ma$$

$$T = \frac{1}{f}$$

Variables

a = acceleration	PE = gravitational potential energy
c = specific heat	q = charge of particle
d = distance	Q = heat
Δd = change in distance	R = resistance
f = frequency	Δt = change in time
F = force	ΔT = change in temperature
Δh = change in height	T = period
I = current	v = velocity
KE = kinetic energy	v_i = initial velocity
λ = wavelength	v_f = final velocity
m = mass	Δv = change in velocity
p = momentum	V = voltage
P = power	W = work

Definitions

$$G = \text{Universal gravitational constant} = 6.67 \times 10^{-11} \frac{\text{N} \cdot \text{m}^2}{\text{kg}^2}$$

$$k = \text{Coulomb constant} = 8.99 \times 10^9 \frac{\text{N} \cdot \text{m}^2}{\text{C}^2}$$

$$c = \text{speed of electromagnetic waves} = 3.00 \times 10^8 \text{ m/s}$$

$$g \approx 10 \text{ m/s}^2 \quad 1 \text{ N} = \frac{1 \text{ kg} \cdot \text{m}}{\text{s}^2} \quad 1 \text{ J} = 1 \text{ N} \cdot \text{m} \quad 1 \text{ W (watt)} = \frac{1 \text{ J}}{\text{s}}$$

High School Introductory Physics
Spring 2007 Released Items:
Reporting Categories, Standards, and Correct Answers

Item No.	Page No.	Reporting Category	Standard	Correct Answer (MC)*
1	513	<i>Motion and Forces</i>	1.6	C
2	513	<i>Heat and Heat Transfer</i>	3.3	D
3	513	<i>Electromagnetism</i>	5.2	D
4	513	<i>Waves and Radiation</i>	4.1	C
5	514	<i>Motion and Forces</i>	1.4	A
6	514	<i>Heat and Heat Transfer</i>	3.4	C
7	514	<i>Motion and Forces</i>	2.5	C
8	515	<i>Motion and Forces</i>	2.2	B
9	515	<i>Heat and Heat Transfer</i>	3.1	B
10	515	<i>Motion and Forces</i>	1.4	A
11	516	<i>Electromagnetism</i>	5.1	
12	517	<i>Heat and Heat Transfer</i>	3.3	D
13	517	<i>Waves and Radiation</i>	4.1	D
14	517	<i>Heat and Heat Transfer</i>	3.4	C
15	517	<i>Motion and Forces</i>	1.1	B
16	518	<i>Heat and Heat Transfer</i>	3.3	A
17	518	<i>Electromagnetism</i>	5.2	D
18	519	<i>Waves and Radiation</i>	4.1	C
19	519	<i>Motion and Forces</i>	1.4	B
20	520	<i>Electromagnetism</i>	5.1	D
21	520	<i>Electromagnetism</i>	5.2	B
22	521	<i>Waves and Radiation</i>	4.2	A
23	521	<i>Heat and Heat Transfer</i>	3.4	B
24	521	<i>Heat and Heat Transfer</i>	3.3	D
25	522	<i>Motion and Forces</i>	2.5	
26	523	<i>Waves and Radiation</i>	4.3	
27	524	<i>Motion and Forces</i>	2.5	B
28	524	<i>Waves and Radiation</i>	4.1	D
29	524	<i>Waves and Radiation</i>	6.2	D
30	525	<i>Motion and Forces</i>	2.4	A
31	525	<i>Waves and Radiation</i>	4.2	D
32	526	<i>Electromagnetism</i>	5.2	
33	527	<i>Waves and Radiation</i>	4.3	D
34	527	<i>Motion and Forces</i>	1.2	C
35	527	<i>Waves and Radiation</i>	4.2	D
36	527	<i>Motion and Forces</i>	2.4	C
37	528	<i>Motion and Forces</i>	1.3	D
38	528	<i>Waves and Radiation</i>	6.1	A
39	529	<i>Motion and Forces</i>	1.4	
40	530	<i>Motion and Forces</i>	2.1	B
41	530	<i>Motion and Forces</i>	2.2	C
42	530	<i>Waves and Radiation</i>	6.2	B

Item No.	Page No.	Reporting Category	Standard	Correct Answer (MC)*
43	531	<i>Motion and Forces</i>	2.5	C
44	531	<i>Motion and Forces</i>	1.7	B
45	531	<i>Heat and Heat Transfer</i>	3.3	B

* Answers are provided here for multiple-choice items only. Sample responses and scoring guidelines for open-response items, which are indicated by shaded cells, will be posted to the Department's Web site later this year.

XXI. Technology/Engineering,
High School

High School Technology/Engineering Test

The spring 2007 high school MCAS Technology/Engineering test was based on learning standards in the Technology/Engineering content strand of the Massachusetts *Science and Technology/Engineering Curriculum Framework* (2006). These learning standards appear on pages 92–95 of the *Framework*.

The *Science and Technology/Engineering Curriculum Framework* is available on the Department Web site at www.doe.mass.edu/frameworks/current.html.

In *Test Item Analysis Reports* and on the Subject Area Subscore pages of the MCAS *School Reports* and *District Reports*, Technology/Engineering test results are reported under the following four MCAS reporting categories:

- Engineering Design
- Construction and Manufacturing
- Fluid and Thermal Systems
- Electrical and Communications Systems

Test Sessions

The MCAS high school Technology/Engineering test included two separate test sessions, which were administered on consecutive days. Each session included multiple-choice and open-response questions.

Reference Materials and Tools

Each student taking the high school Technology/Engineering test was provided with a plastic ruler and a Technology/Engineering Formula Sheet. A copy of this formula sheet follows the final question in this chapter. An image of the ruler is not reproduced in this publication.

Each student also had sole access to a calculator with at least four functions and a square-root key.

The use of bilingual word-to-word dictionaries was allowed for current and former limited English proficient students only, during both Technology/Engineering test sessions. No other reference tools or materials were allowed.

Cross-Reference Information

The table at the conclusion of this chapter indicates each item's reporting category and the *Framework* learning standard it assesses. The correct answers for multiple-choice questions are also displayed in the table.

Technology/Engineering

SESSION 1

DIRECTIONS

This session contains twenty-three multiple-choice questions and two open-response questions. Mark your answers to these questions in the spaces provided in your Student Answer Booklet. You may work out solutions to multiple-choice questions in the test booklet.

- 1 Which of the following would **best** increase the year-round energy efficiency of a building that is subjected to hot summers and cold winters?
- A. black exterior paint
 - B. fiberglass insulation
 - C. large glass windows
 - D. white exterior paint
- 2 Air in a hydraulic brake line causes the brakes to malfunction. Which property of air is **most** responsible for the malfunction?
- A. Air is less visible than brake fluid.
 - B. Air changes volume under pressure.
 - C. Air causes corrosion in the brake line.
 - D. Air changes temperature under pressure.
- 3 Which of the following is a function of a home TV antenna?
- A. transmitter
 - B. storage
 - C. source
 - D. receiver
- 4 In one type of home air conditioner thermostat, the case of the temperature sensor is made of metal. Which of the following is the **best** reason for using metal?
- A. Metal convects heat easily.
 - B. Metal conducts heat quickly.
 - C. Metal consumes heat slowly.
 - D. Metal radiates heat efficiently.

- 5 The drawing below shows a spring-loaded stamping machine.

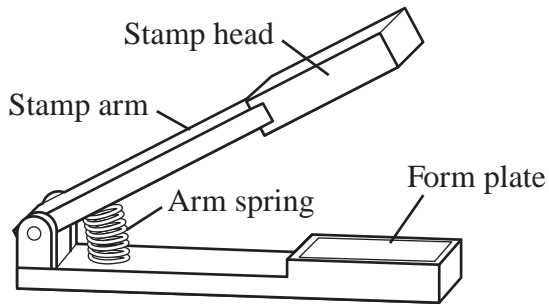

Which of the following is the **main** function of the arm spring?

- A. to provide increased resistance to the stamping force
- B. to return the stamp arm to an open position quickly
- C. to prevent the stamp head from contacting the form plate
- D. to press the stamp arm toward the form plate automatically

- 6 Which of the following is used to read a compact disc in a compact disc player?

- A. polarization
- B. microwaves
- C. a magnet
- D. a laser

7 Designers need to use a wind tunnel to test the airflow over a new design for an airplane wing. Since the wind tunnel is not large enough to hold the actual airplane wing, the designers will need to use which of the following?

- A. a mockup
- B. a propeller
- C. a scale model
- D. an orthographic projection

8 The drawing below represents a corner brace.

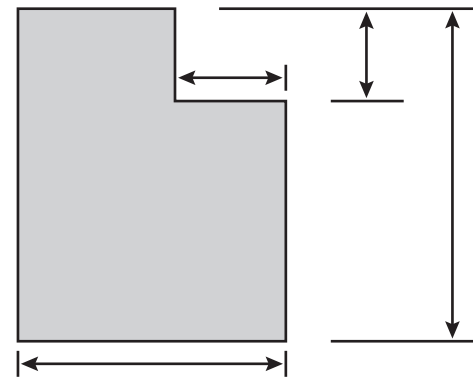

Drawn by: John Q.
Sheet 1 of 1

Scale 1 cm: 25 cm
Date 12/10/02

Which of the following is the height of the corner brace?

- A. 50 cm
- B. 80 cm
- C. 90 cm
- D. 110 cm

- 9 A circuit has a source with an electrical potential of 12 V. The circuit contains one resistor.

If a second resistor is added to the circuit in series, what effect will this have on the current in the circuit?

- A. The current will increase.
- B. The current will decrease.
- C. The current will not be affected.
- D. The current will switch from DC to AC.

- 10 The diagram below shows the seat belt mechanism in a car.

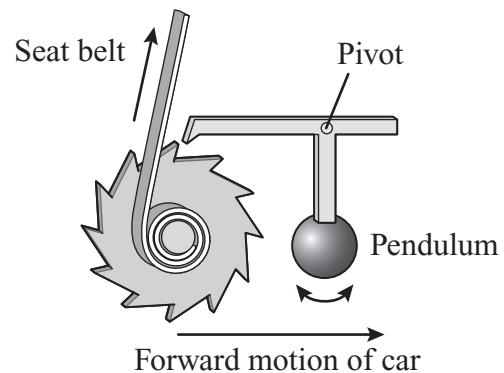

Which of the following correctly describes the working of this mechanism?

- A. Pulling on the seat belt will move the pendulum forward.
- B. Pulling on the seat belt will move the pendulum backward.
- C. When the pendulum swings forward, the seat belt will latch.
- D. When the pendulum swings backward, the seat belt will latch.

Question 11 is an open-response question.

- **BE SURE TO ANSWER AND LABEL ALL PARTS OF THE QUESTION.**
- **Show all your work (diagrams, tables, or computations) in your Student Answer Booklet.**
- **If you do the work in your head, explain in writing how you did the work.**

Write your answer to question 11 in the space provided in your Student Answer Booklet.

- 11** The drawing below shows a U-shaped block made from a cube of metal.

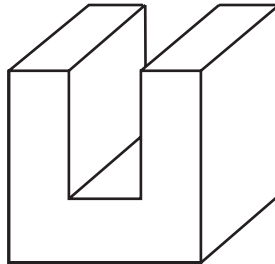

- In your Student Answer Booklet, make a multi-view drawing of this block. Be sure to include a top view, front view, and right side view, and include any hidden lines that are necessary.
- In your Student Answer Booklet, using the same size and scale as in part (a), make an isometric drawing of this block.

Mark your answers to multiple-choice questions 12 through 24 in the spaces provided in your Student Answer Booklet. Do not write your answers in this test booklet, but you may work out solutions to multiple-choice questions in the test booklet.

12 In which of the following fluid systems does the fluid remain within the system?

- A. compressed air in a gas station
- B. steam engine on a railroad train
- C. forced hot water heating in a home
- D. forced hot air heating in a car repair shop

13 Which of the following is the **best** example of heat transfer by convection?

A.

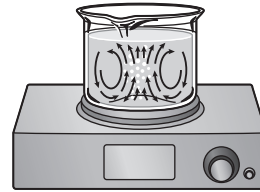

from the lower
water to the surface

B.



from the iron
to the shirt

C.

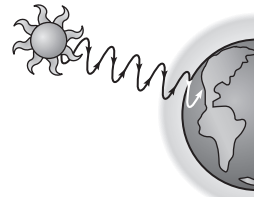

from the Sun
to Earth

D.



from the griddle
to the eggs

- 14 The figure below represents a spring scale used in a grocery store.

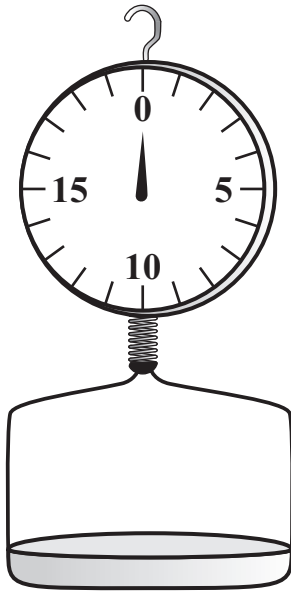

Which of the following properties is **most** important for the spring in this scale?

- A. density
- B. ductility
- C. elasticity
- D. plasticity

- 15 The figure below shows a water cooler.

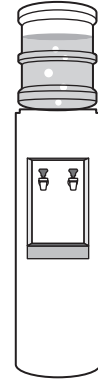

This water cooler holds a 20-liter water bottle. The cooler weighs 150 lb. with an empty water bottle. Each liter of water weighs 2.2 lb.

What is the live load on the water cooler with a full bottle of water?

- A. 44 lb.
 - B. 152 lb.
 - C. 330 lb.
 - D. 374 lb.
- 16 Digital information is transmitted over fiberoptic cable as pulses of which of the following?
- A. electricity
 - B. light
 - C. microwaves
 - D. sound

17 A structural component for a bridge needs to be especially strong in tension. Which of the following materials would be **most** suitable for this component?

- A. concrete
- B. copper
- C. steel
- D. wood

18 A company sent prototypes of a newly designed hair dryer for trial use to 100 homes along with a satisfaction survey. A month later the company received 82 completed surveys.

This process is part of which of the following steps in the engineering design process?

- A. developing possible solutions
- B. communicating the solution
- C. researching the problem
- D. evaluating outcomes

19 The floor plans for a house are shown below.

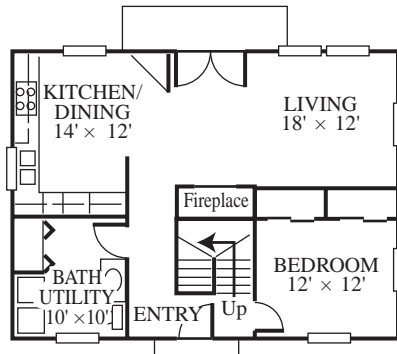

First floor

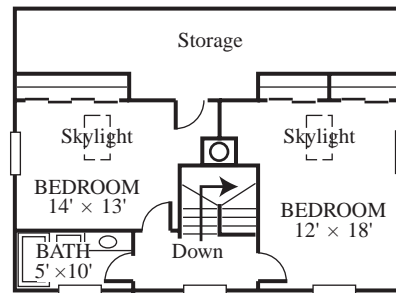

Second floor

Which of the following houses corresponds to these floor plans?



20 Which of the following processes can be used to make an imprint of a footprint found on a trail?

- A. casting
- B. extruding
- C. tempering
- D. thermosetting

21 An architect knows that a home receiving a lot of exposure to the Sun will benefit from the heating effects of sunlight if there is a lot of glass in the home's design.

By which of the following methods will sunlight heat the home?

- A. conduction
- B. convection
- C. evaporation
- D. radiation

22 The diagram below represents a circuit.

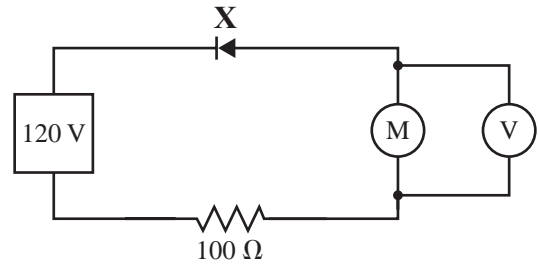

What is the function of the circuit component labeled **X**?

- A. to restrict current flow in all directions
- B. to restrict current flow in one direction
- C. to increase current flow in all directions
- D. to increase current flow in one direction

- 23 The drawing below represents a beam with a weight resting in the middle.

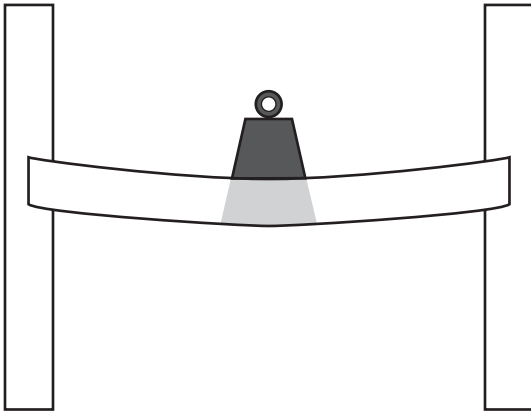

Which of the following internal stresses occur in the shaded region of the beam when it is stressed by this weight?

- A. compression and torsion
- B. compression and tension
- C. torsion and shear
- D. torsion and tension

- 24 Water moving through a fire hydrant with an internal cross-sectional area of about 20 sq. in. goes into a fire hose with a cross-sectional area of about 5 sq. in.

Which of the following is the **best** estimate of the change in speed of the water?

- A. The speed of the water in the hose is 0.25 times the speed of the water in the hydrant.
- B. The speed of the water in the hose is 0.5 times the speed of the water in the hydrant.
- C. The speed of the water in the hose is 2 times the speed of the water in the hydrant.
- D. The speed of the water in the hose is 4 times the speed of the water in the hydrant.

Question 25 is an open-response question.

- **BE SURE TO ANSWER AND LABEL ALL PARTS OF THE QUESTION.**
- **Show all your work (diagrams, tables, or computations) in your Student Answer Booklet.**
- **If you do the work in your head, explain in writing how you did the work.**

Write your answer to question 25 in the space provided in your Student Answer Booklet.

25 The diagram below shows a simple circuit that operates a motor.

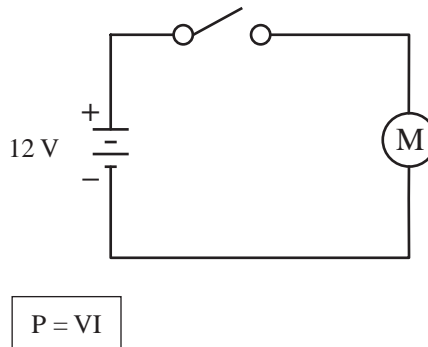

- What is the power consumption of the motor if the current in this circuit is 2.0 A when the switch is closed? Show your calculations and include units in your answer.
- If the voltage of the source is increased, how will the current in the circuit change?
- A fuse is often used to protect a circuit. Which of the following schematics shows a correct placement for the fuse?

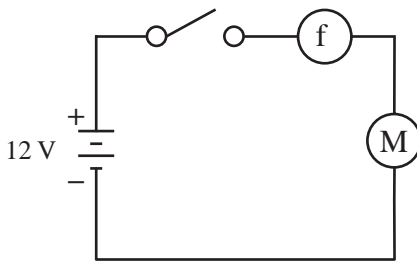

Option X

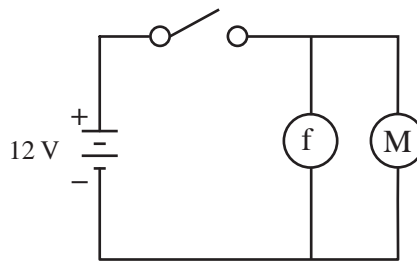

Option Y

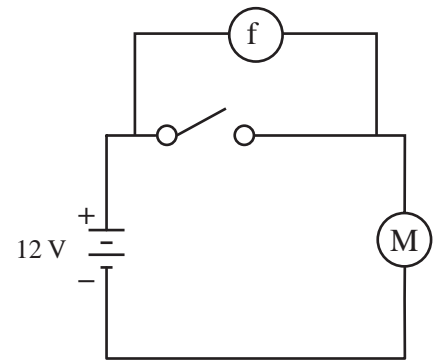

Option Z

- Explain your answer to part (c).

Technology/Engineering

SESSION 2

DIRECTIONS

This session contains seventeen multiple-choice questions and three open-response questions. Mark your answers to these questions in the spaces provided in your Student Answer Booklet. You may work out solutions to multiple-choice questions in the test booklet.

- 26 In which of the following examples would a hydraulic system be useful?
- A. inflating an automobile tire
 - B. lifting a 2-ton piece of machinery
 - C. wiring light bulbs in an electric circuit
 - D. sending millions of messages across the Atlantic Ocean each day

- 27 The drawing below shows an angle block.

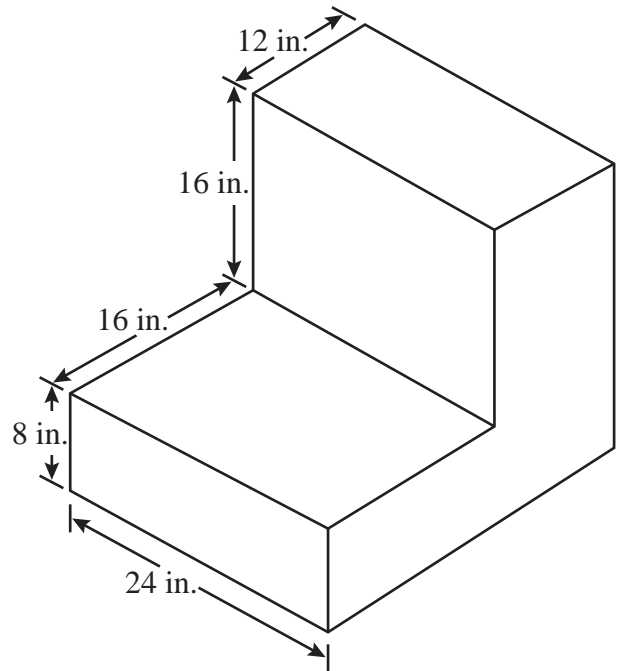

This angle block has a width of 24 in. The width of the drawn figure is 1.5 in. Which of the following is the scale used in this drawing?

- A. 1:8
- B. 1:16
- C. 1:24
- D. 1:36

- 28 The diagram below shows a concrete beam supported by two equally spaced columns.

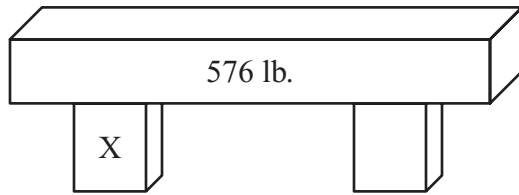

Which of the following is the dead load on column X?

- A. 36 lb.
- B. 144 lb.
- C. 288 lb.
- D. 576 lb.

- 29 An exchange student in Europe calls a friend in Boston. The call travels through a fiberoptic cable under the ocean.

Which of the following components of the communications system converts the student's voice into light pulses that can be carried through the fiberoptic cable?

- A. encoder
- B. retriever
- C. source
- D. decoder

- 30 The diagram below shows an air hose positioned so that a stream of air can be passed above the end of a glass tube. The glass tube is sitting in a beaker of water. Its support is not shown.

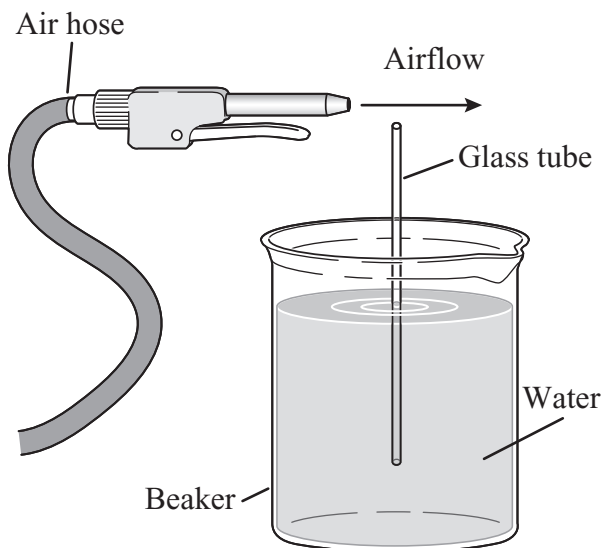

According to Bernoulli's principle, what will happen as the stream of air passes over the glass tube?

- A. Turbulence will cause the glass tube to tilt toward the left.
- B. Wind shear will cause the glass tube to break at the lip of the beaker.
- C. Low pressure will develop and cause the water level to rise in the glass tube.
- D. Lift will develop in the glass tube and cause the water in the beaker to overflow.

- 31 In the winter, heavy curtains are often hung in front of windows. What effect do these curtains have on heat transfer?

- A. The curtains reduce convective heat transfer.
- B. The curtains increase conductive heat transfer.
- C. The curtains reduce heat transfer from evaporation.
- D. The curtains increase heat transfer from condensation.

32 The owners of a grocery store chain have decided to try a hand-held bar code scanner for customers to use as they shop. After developing the prototype of the hand-held bar code scanner, what is the next step in the new product development?

- A. refining the scanner for production
- B. advertising the scanner in all stores
- C. field testing the scanner in selected stores
- D. mass-producing the scanner for all stores

33 The diagram below represents a parallel circuit.

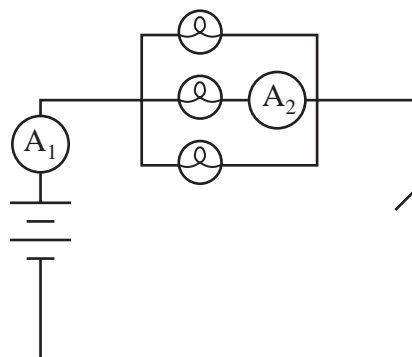

All three bulbs in this circuit are identical. When the switch is closed, if ammeter A_1 measures a current of 2.0 A, which of the following is the current through A_2 ?

- A. 0.67 A
- B. 1.3 A
- C. 2.0 A
- D. 6.0 A

Question 34 is an open-response question.

- **BE SURE TO ANSWER AND LABEL ALL PARTS OF THE QUESTION.**
- **Show all your work (diagrams, tables, or computations) in your Student Answer Booklet.**
- **If you do the work in your head, explain in writing how you did the work.**

Write your answer to question 34 in the space provided in your Student Answer Booklet.

- 34 The diagrams below represent a coaxial cable and an optical-fiber cable.

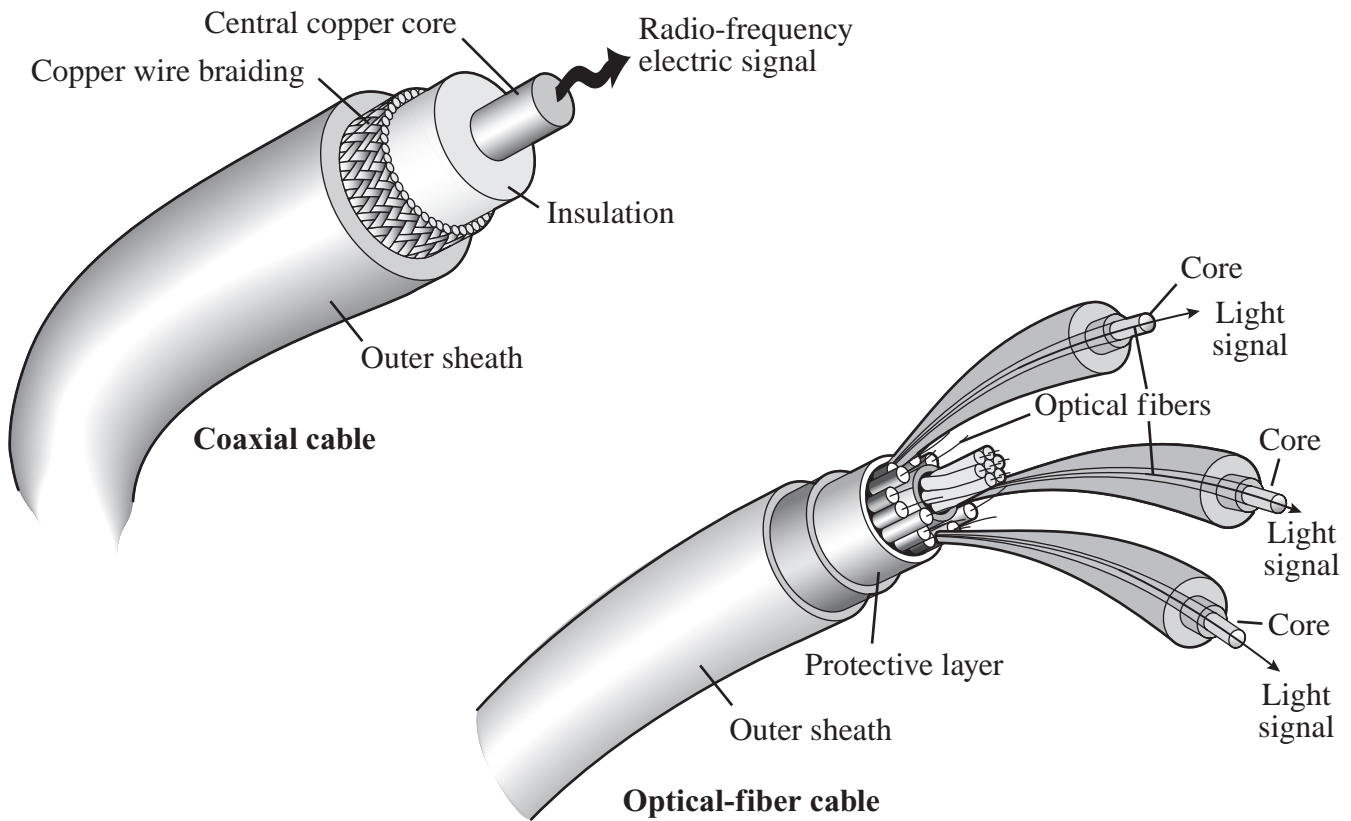

In the telecommunication industry, optical-fiber cable is replacing coaxial cable.

Describe **four** advantages of optical-fiber cable over coaxial cable.

Mark your answers to multiple-choice questions 35 through 37 in the spaces provided in your Student Answer Booklet. Do not write your answers in this test booklet, but you may work out solutions to multiple-choice questions in the test booklet.

35 Which of the following will offer the **most** resistance to water flow?

- A. a pipe with a large diameter
- B. a pipe with several elbows
- C. a pipe with no corrosion
- D. a pipe that is straight

36 The diagram below represents a circuit.

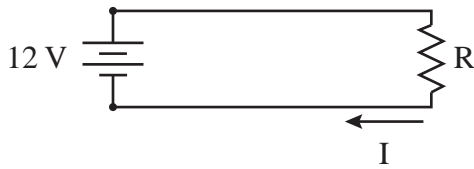

Ohm's law

$$I = \frac{V}{R}$$

If the voltage is held constant at 12 V, which of the following describes the effect of doubling the resistance R?

- A. The new current is $\frac{1}{4}$ of the original.
- B. The new current is $\frac{1}{2}$ of the original.
- C. The new current is 2 times the original.
- D. The new current is 4 times the original.

37 Carlos wants to use a pneumatic system to operate an assembly line. Which of the following must be included in the pneumatic system?

- A. transformers, generators, and turbines
- B. pumps, lines, and oil
- C. motors, gears, and electrical switches
- D. compressors, valves, and air

Questions 38 and 39 are open-response questions.

- **BE SURE TO ANSWER AND LABEL ALL PARTS OF EACH QUESTION.**
- **Show all your work (diagrams, tables, or computations) in your Student Answer Booklet.**
- **If you do the work in your head, explain in writing how you did the work.**

Write your answer to question 38 in the space provided in your Student Answer Booklet.

- 38 The diagram below represents a saucepan on a hot plate.

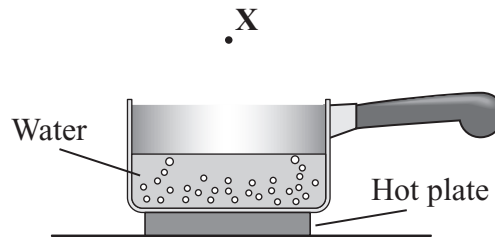

The saucepan is partially filled with water and the hot plate is turned on. After some time, the air at point **X** above the pan becomes hot.

- Explain how heat is transferred from the hot plate to the base of the saucepan.
- Explain how heat is transferred from the base of the saucepan to all of the water in the saucepan.
- Explain how heat is transferred from the hot water to the air at point **X**.

Write your answer to question 39 in the space provided in your Student Answer Booklet.

- 39** Traditionally, automotive companies manufactured car bodies and engines from metals such as steel. Now, some automotive companies have started to manufacture cars with plastic exterior body panels, including doors and fenders.
- From an engineering standpoint, give **one** reason why metals have traditionally been used for body panels in cars.
 - Identify **three** advantages of using plastics for body panels.
 - Explain why automotive companies are not currently able to build engines from plastics.

Mark your answers to multiple-choice questions 40 through 45 in the spaces provided in your Student Answer Booklet. Do not write your answers in this test booklet, but you may work out solutions to multiple-choice questions in the test booklet.

40 Which of the following environmental conditions will result in the **most** heat loss from a house on a cool day?

- A. bright sun
- B. heavy fog
- C. high wind
- D. light rain

41 Which of the following would be the most important property to test when developing a paper filter for a coffeemaker?

- A. conductivity
- B. density
- C. plasticity
- D. porosity

42 Which of the following materials would probably be used as a conductor of electric current in a computer chip?

- A. glass
- B. rubber
- C. gold
- D. plastic

43 A manufacturing company is producing a metal pan from an $18'' \times 26''$ piece of sheet metal. Two sequential phases of the production are shown below.

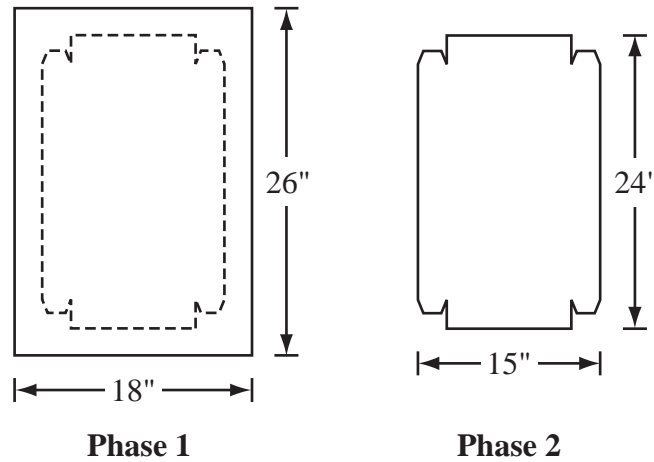

Which of the following processes is completed from Phase 1 to Phase 2?

- A. assembling
- B. separating
- C. finishing
- D. forming

- 44 The figure below shows insulation being sprayed into a wall.



Which of the following is the **most** desirable property of this type of insulation?

- A. high retention of water
- B. high thermal expansion
- C. low coefficient of elasticity
- D. low heat transfer coefficient

- 45 Communication satellites have which of the following functions in radio and television broadcasting?

- A. encoder and source
- B. retrieval and source
- C. receiver and transmitter
- D. destination and receiver

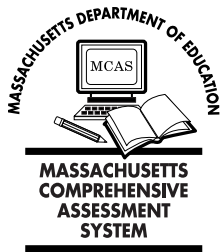

Massachusetts Comprehensive Assessment System

Technology/Engineering Formula Sheet

Formulas

$$I = \frac{V}{R}$$

$$\text{Pressure} = \frac{\text{Force}}{\text{Area}}$$

$$P = I \times V$$

$$\text{Area of a circle} = \pi r^2$$

Variables

I = current

r = radius

P = power

R = resistance

V = voltage

Definitions

AC = alternating current

psi = pounds per square inch

DC = direct current

$\pi \cong 3.14$

**High School Technology/Engineering
Spring 2007 Released Items:
Reporting Categories, Standards, and Correct Answers**

Item No.	Page No.	Reporting Category	Standard	Correct Answer (MC)*
1	537	<i>Fluid and Thermal Systems</i>	4.3	B
2	537	<i>Fluid and Thermal Systems</i>	3.2	B
3	537	<i>Electrical and Communications Systems</i>	6.3	D
4	537	<i>Fluid and Thermal Systems</i>	4.2	B
5	538	<i>Engineering Design</i>	1.5	B
6	538	<i>Electrical and Communications Systems</i>	6.4	D
7	539	<i>Engineering Design</i>	1.1	C
8	539	<i>Engineering Design</i>	1.4	D
9	540	<i>Electrical and Communications Systems</i>	5.3	B
10	540	<i>Engineering Design</i>	1.5	C
11	541	<i>Engineering Design</i>	1.3	
12	542	<i>Fluid and Thermal Systems</i>	3.1	C
13	542	<i>Fluid and Thermal Systems</i>	4.1	A
14	543	<i>Construction and Manufacturing</i>	2.1	C
15	543	<i>Construction and Manufacturing</i>	2.4	A
16	543	<i>Electrical and Communications Systems</i>	6.1	B
17	544	<i>Construction and Manufacturing</i>	2.2	C
18	544	<i>Engineering Design</i>	1.1	D
19	545	<i>Engineering Design</i>	1.5	A
20	546	<i>Construction and Manufacturing</i>	7.1	A
21	546	<i>Fluid and Thermal Systems</i>	4.3	D
22	546	<i>Electrical and Communications Systems</i>	5.2	B
23	547	<i>Construction and Manufacturing</i>	2.2	B
24	547	<i>Fluid and Thermal Systems</i>	3.4	D
25	548	<i>Electrical and Communications Systems</i>	5.1	
26	549	<i>Fluid and Thermal Systems</i>	3.2	B
27	549	<i>Engineering Design</i>	1.4	B
28	550	<i>Construction and Manufacturing</i>	2.4	C
29	550	<i>Electrical and Communications Systems</i>	6.3	A
30	551	<i>Construction and Manufacturing</i>	2.3	C
31	551	<i>Fluid and Thermal Systems</i>	4.2	A
32	552	<i>Engineering Design</i>	1.1	C
33	552	<i>Electrical and Communications Systems</i>	5.1	A
34	553	<i>Electrical and Communications Systems</i>	6.5	
35	554	<i>Fluid and Thermal Systems</i>	3.5	B
36	554	<i>Electrical and Communications Systems</i>	5.3	B
37	554	<i>Fluid and Thermal Systems</i>	3.2	D
38	555	<i>Fluid and Thermal Systems</i>	4.1	
39	556	<i>Construction and Manufacturing</i>	7.2	
40	557	<i>Fluid and Thermal Systems</i>	4.3	C
41	557	<i>Construction and Manufacturing</i>	2.1	D
42	558	<i>Electrical and Communications Systems</i>	5.2	C

Item No.	Page No.	Reporting Category	Standard	Correct Answer (MC)*
43	558	<i>Construction and Manufacturing</i>	7.1	B
44	559	<i>Construction and Manufacturing</i>	2.1	D
45	559	<i>Electrical and Communications Systems</i>	6.3	C

* Answers are provided here for multiple-choice items only. Sample responses and scoring guidelines for open-response items, which are indicated by shaded cells, will be posted to the Department's Web site later this year.

XXII. History and Social Science, Grade 5

Grade 5 History and Social Science Test

The spring 2007 grade 5 MCAS History and Social Science test was based on learning standards and concepts and skills for grades 4 and 5 found on pages 22–32 of the Massachusetts *History and Social Science Curriculum Framework* (2003). This framework is available on the Department Web site at www.doe.mass.edu/frameworks/current.html.

The test items that appear on the following pages compose one-half of the common items that appeared on the grade 5 History and Social Science test.

In *Test Item Analysis Reports*, grade 5 History and Social Science test results are reported under three reporting categories:

- North American Geography
- American History (to 1820)
- Civics and Government, Economics

For detailed information about the distribution of grade 5 test items by reporting category, please consult pages 4–5 of the *MCAS Guide to History and Social Science Assessments* (February 2007). This publication is available on the Department Web site at www.doe.mass.edu/mcas/2007/admin/hssguide.pdf.

Test Sessions and Content Overview

The 2007 grade 5 MCAS History and Social Science test included two separate test sessions. Each session included multiple-choice and open-response questions.

Reference Materials and Tools

The use of bilingual word-to-word dictionaries was allowed for current and former limited English proficient students only, during both History and Social Science test sessions. No other reference materials were allowed.

Cross-Reference Information

The table at the conclusion of this chapter indicates each item’s reporting category as well as the learning standard or concept and skill it assesses. The coding for grade-level learning standards appears in the table as it appears in the *Framework*. The codes containing the letters “CS” represent standards listed in the Concepts and Skills section of the *Framework* for that grade level.

History and Social Science

SESSION 1

DIRECTIONS

This session contains eleven multiple-choice questions and one open-response question. Mark your answers to these questions in the spaces provided in your Student Answer Booklet.

- 1 The photograph below shows a historic sculpture in our nation's capital.



Sculpture by Daniel Chester French;
photograph © Lester Lefkowitz/CORBIS

The sculpture in the photograph is located in which of the following buildings?

- A. the White House
- B. the Lincoln Memorial
- C. the Jefferson Memorial
- D. the Washington Monument

- 2 During colonial times, only white men with property had suffrage. What does *suffrage* mean?

- A. the right to vote
- B. the right to travel
- C. the right to protest
- D. the right to worship

- 3 Which religion do **most** of the people in Canada practice?

- A. Buddhism
- B. Christianity
- C. Islam
- D. Judaism

- 4 The Northern Hemisphere is all the land and water north of the

- A. equator.
- B. South Pole.
- C. Arctic Circle.
- D. prime meridian.

- 5 Why was Shays's Rebellion important to the call for a Constitutional Convention in 1787?
- A. It demonstrated the threat of slave revolts.
 - B. It demonstrated the danger of a British army.
 - C. It demonstrated the power of the British Colonial Office.
 - D. It demonstrated the need for a stronger national government.

- 6 Which colonial leader founded Rhode Island in the 1600s to promote freedom of worship?
- A. John Smith
 - B. William Penn
 - C. John Winthrop
 - D. Roger Williams

- 7 The map below shows the continental United States with regions labeled A, B, C, and D.

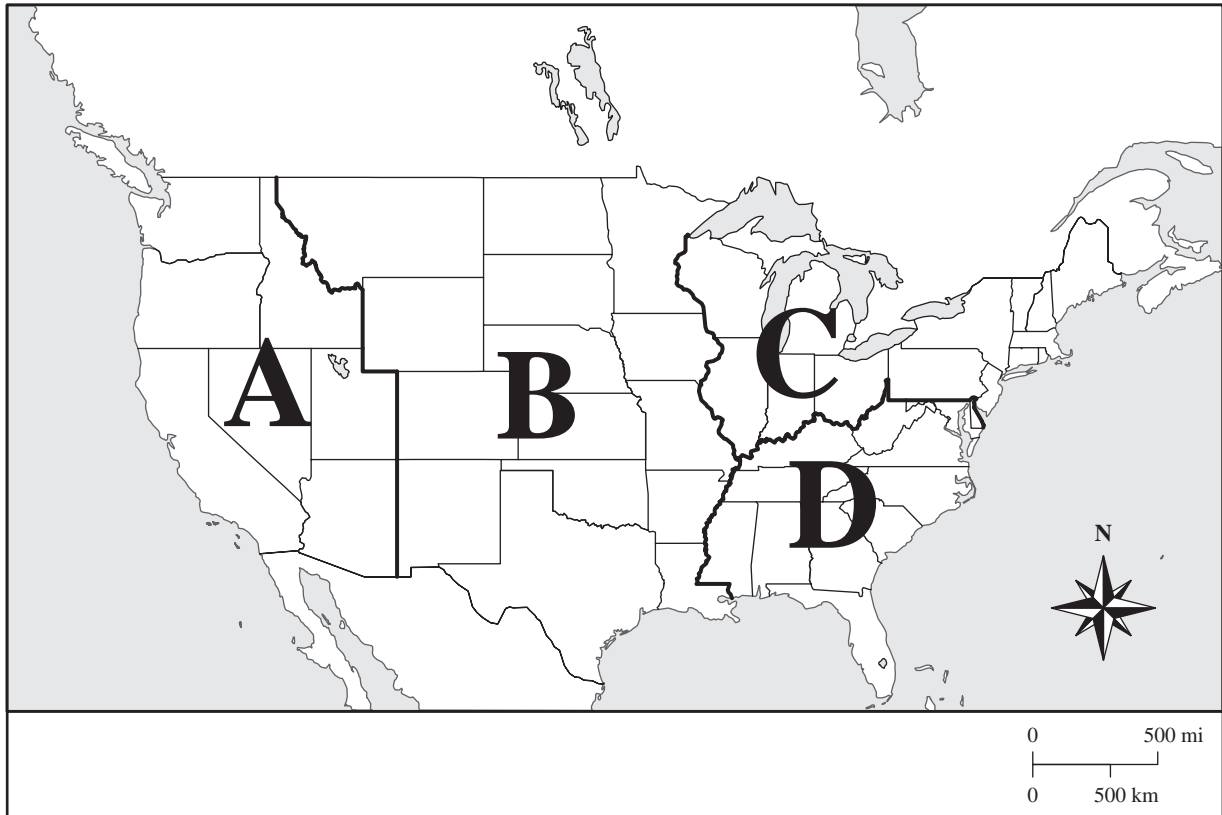

Chicago and Detroit are major cities in which region?

- A. A
- B. B
- C. C
- D. D

The map below shows the route of the Lewis and Clark expedition in the 19th century.

First, you will answer three multiple-choice questions. Then you will answer two parts of an open-response question about the importance of Lewis and Clark’s journey.

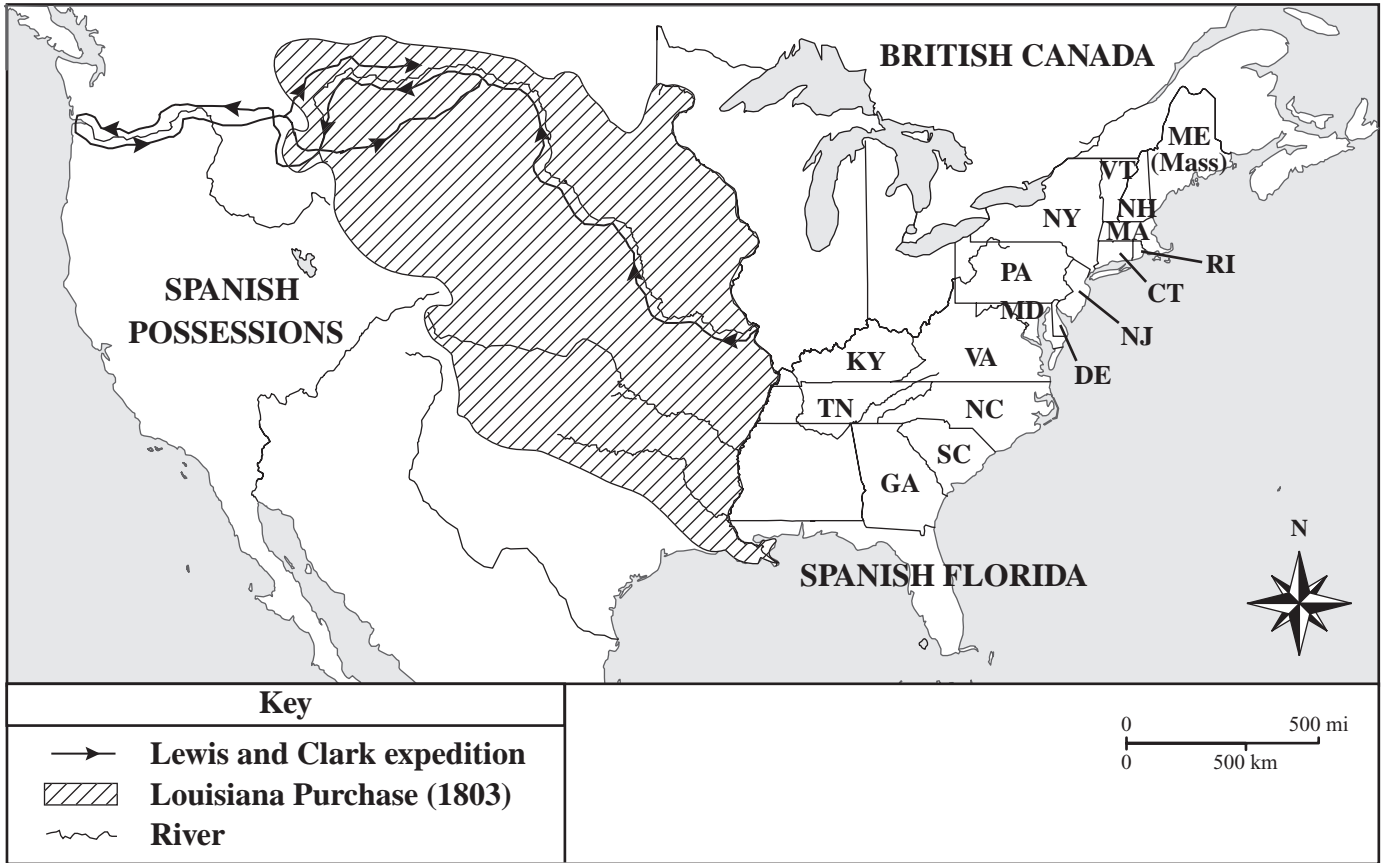

Mark your answers to questions 8 through 10 in the spaces provided in your Student Answer Booklet.

- 8 The Lewis and Clark expedition explored which of the following rivers?
- A. the Charles River
 - B. the Colorado River
 - C. the Hudson River
 - D. the Missouri River
- 9 In which of the following towns did Lewis and Clark begin their expedition?
- A. Chicago
 - B. New Orleans
 - C. St. Louis
 - D. Washington DC
- 10 Which president sent Lewis and Clark on their expedition?
- A. John Adams
 - B. James Madison
 - C. Thomas Jefferson
 - D. George Washington

Write your answer to open-response question 11 in the space provided in your Student Answer Booklet.

- 11 After traveling for more than two years, Lewis and Clark returned from their journey in the fall of 1806.
- a. Identify and describe **three** discoveries that Lewis and Clark made on their journey. Your answer may include people they met, places they saw, and/or plants and animals they found. Support your answer with specific examples based on the map and your knowledge of American history.
 - b. Discuss **one** way in which Lewis and Clark's expedition was important to the United States at that time in America's history. Support your answer with specific examples based on the map and your knowledge of American history.

Mark your answer to question 12 in the space provided in your Student Answer Booklet.

12 The table below describes the federal government.

Government Branch	Member
Executive Branch	President
Legislative Branch	Congress
Judicial Branch	?

Which of the following belongs in the box with the question mark?

- A. Senate
- B. Cabinet
- C. Supreme Court
- D. House of Representatives

History and Social Science

SESSION 2

DIRECTIONS

This session contains five multiple-choice questions. Mark your answers to these questions in the spaces provided in your Student Answer Booklet.

- 13 The map below shows the continental United States with several cities labeled. Some lines of latitude and longitude are also indicated.

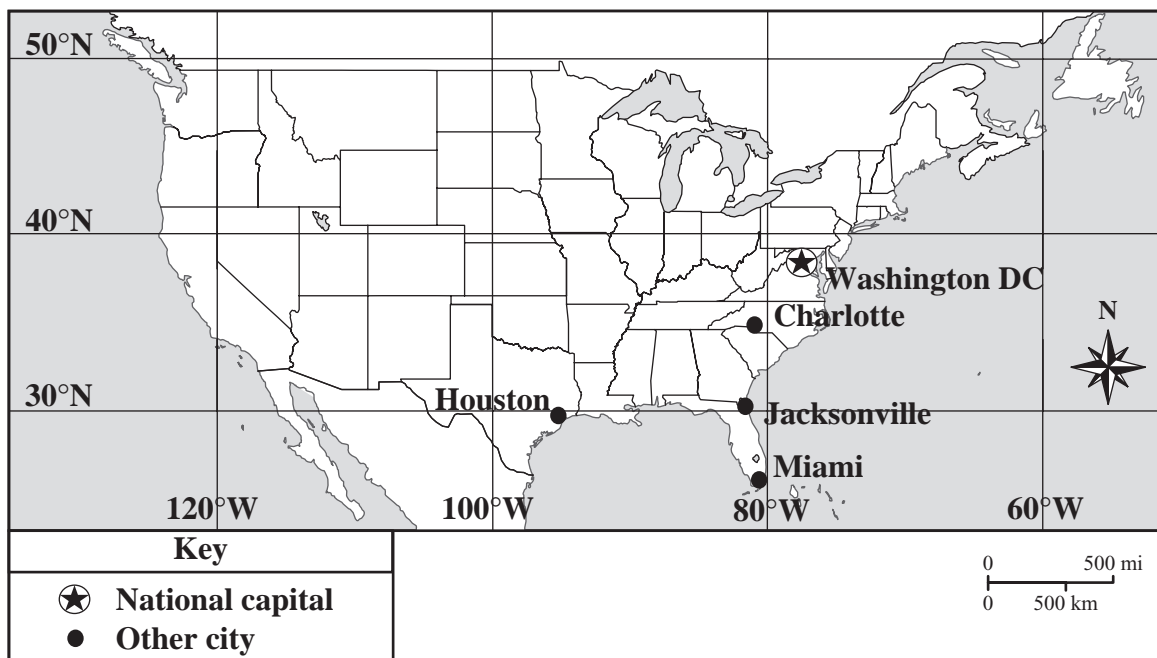

Based on the map, which city is located closest to 30°N and 80°W?

- A. Charlotte
- B. Houston
- C. Jacksonville
- D. Miami

- 14 In colonial America, which of the following activities would have been **most** affected by an increase in the price of lumber?
- A. growing wheat
 - B. building ships
 - C. dairy farming
 - D. fur trapping

- 15 In which of the following locations have archaeologists found evidence of Viking exploration in North America?
- A. Virginia
 - B. Labrador
 - C. the Gulf of Mexico
 - D. the Mississippi Valley

- 16 The map below shows Mexico with selected features marked.

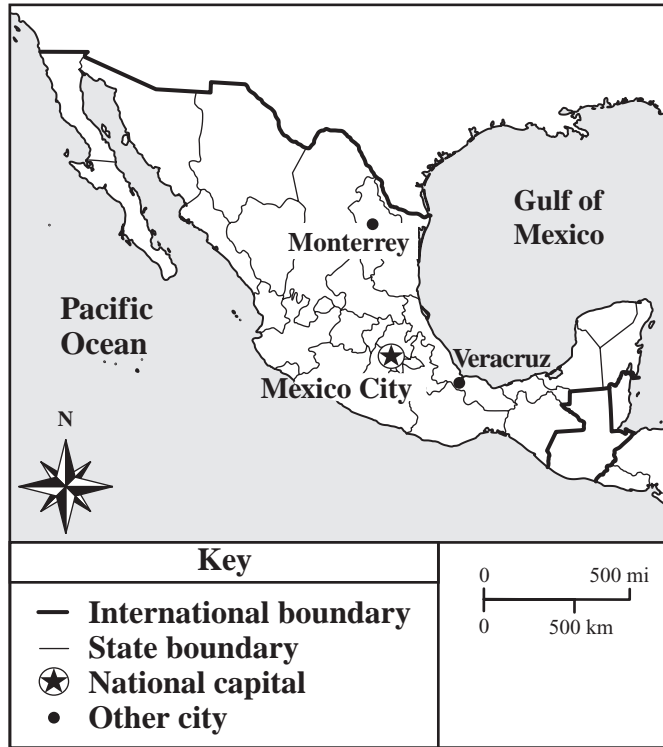

Maps can be used to show many different kinds of information. Which of the following is the **best** title for this map?

- A. Roads of Mexico
- B. Languages of Mexico
- C. Political Map of Mexico
- D. Climate Zone Map of Mexico

- 17 Buyers are not willing to pay the price a seller is charging for telephones. According to the rules of supply and demand, which of the following is **most likely** to happen?
- A. Buyers will make their own telephones.
 - B. Buyers will attempt to barter for telephones.
 - C. The seller will lower the price of telephones.
 - D. The seller will increase the production of telephones.

**Grade 5 History and Social Science
Spring 2007 Released Items:
Reporting Categories, Standards, and Correct Answers**

Item No.	Page No.	Reporting Category	Learning Standard/ Concept and Skill	Correct Answer (MC)*
1	565	<i>North American Geography</i>	4.13	B
2	565	<i>Civics and Government, Economics</i>	5.CS.8	A
3	565	<i>North American Geography</i>	4.19	B
4	565	<i>North American Geography</i>	5.CS.5	A
5	566	<i>American History (to 1820)</i>	5.21	D
6	566	<i>American History (to 1820)</i>	5.7	D
7	567	<i>North American Geography</i>	4.10	C
8	569	<i>American History (to 1820)</i>	5.30	D
9	569	<i>American History (to 1820)</i>	5.30	C
10	569	<i>American History (to 1820)</i>	5.30	C
11	569	<i>American History (to 1820)</i>	5.30	
12	570	<i>Civics and Government, Economics</i>	5.25	C
13	571	<i>North American Geography</i>	4.CS.1	C
14	572	<i>Civics and Government, Economics</i>	5.CS.14	B
15	572	<i>American History (to 1820)</i>	5.1	B
16	573	<i>North American Geography</i>	4.CS.2	C
17	574	<i>Civics and Government, Economics</i>	4.CS.8	C

* Answers are provided here for multiple-choice items only. Sample responses and scoring guidelines for the open-response item, which is indicated by the shaded cell, will be posted to the Department's Web site later this year.

XXIII. History and Social Science, Grade 7

Grade 7 History and Social Science Test

The spring 2007 grade 7 MCAS History and Social Science test was based on learning standards and concepts and skills for grades 6 and 7 found on pages 33–47 of the Massachusetts *History and Social Science Curriculum Framework* (2003). This framework is available on the Department Web site at www.doe.mass.edu/frameworks/current.html.

The test items that appear on the following pages compose one-half of the common items that appeared on the grade 7 History and Social Science test.

In *Test Item Analysis Reports*, grade 7 History and Social Science test results are reported under four reporting categories:

- World Geography 1: Asia (including Australia and Oceania)
- World Geography 2: Europe, Africa, and South America
- Ancient and Classical Civilizations 1: Human Origins and the Rise of Civilization
- Ancient and Classical Civilizations 2: Greece and Rome

For detailed information about the distribution of grade 7 test items by reporting category, please consult pages 4–5 of the *MCAS Guide to History and Social Science Assessments* (February 2007). This publication is available on the Department Web site at www.doe.mass.edu/mcas/2007/admin/hssguide.pdf.

Test Sessions and Content Overview

The 2007 grade 7 MCAS History and Social Science test included two separate test sessions. Each session included multiple-choice and open-response questions.

Reference Materials and Tools

The use of bilingual word-to-word dictionaries was allowed for current and former limited English proficient students only, during both History and Social Science test sessions. No other reference materials were allowed.

Cross-Reference Information

The table at the conclusion of this chapter indicates each item’s reporting category as well as the learning standard or concept and skill it assesses. The coding for grade-level learning standards appears in the table as it appears in the *Framework*. The codes containing the letters “CS” represent standards listed in the Concepts and Skills section of the *Framework* for that grade level.

History and Social Science

SESSION 1

DIRECTIONS

This session contains eleven multiple-choice questions and one open-response question. Mark your answers to these questions in the spaces provided in your Student Answer Booklet.

- 1 Which of the following statements **best** explains why Cairo, Egypt, has grown into a large urban center?
- A. It is located near the Nile River.
 - B. It is located east of Tripoli, Libya.
 - C. It is located west of the Caspian Sea.
 - D. It is located north of Mount Kilimanjaro.

- 2 The government of the Roman Republic was characterized by all of the following features **except**
- A. the rule of law.
 - B. separation of powers.
 - C. the idea of civic duty.
 - D. voting rights for women.

- 3 The map below shows Southeast Asia.



Which Southeast Asian country is shaded on the map?

- A. Cambodia
- B. Laos
- C. Thailand
- D. Vietnam

- 4 The city-states of ancient Greece spread Greek culture to areas around the Mediterranean Sea by
 - A. conquering Rome.
 - B. establishing colonies.
 - C. uniting with Carthage.
 - D. building roads for armies.

5 The map below shows Europe.

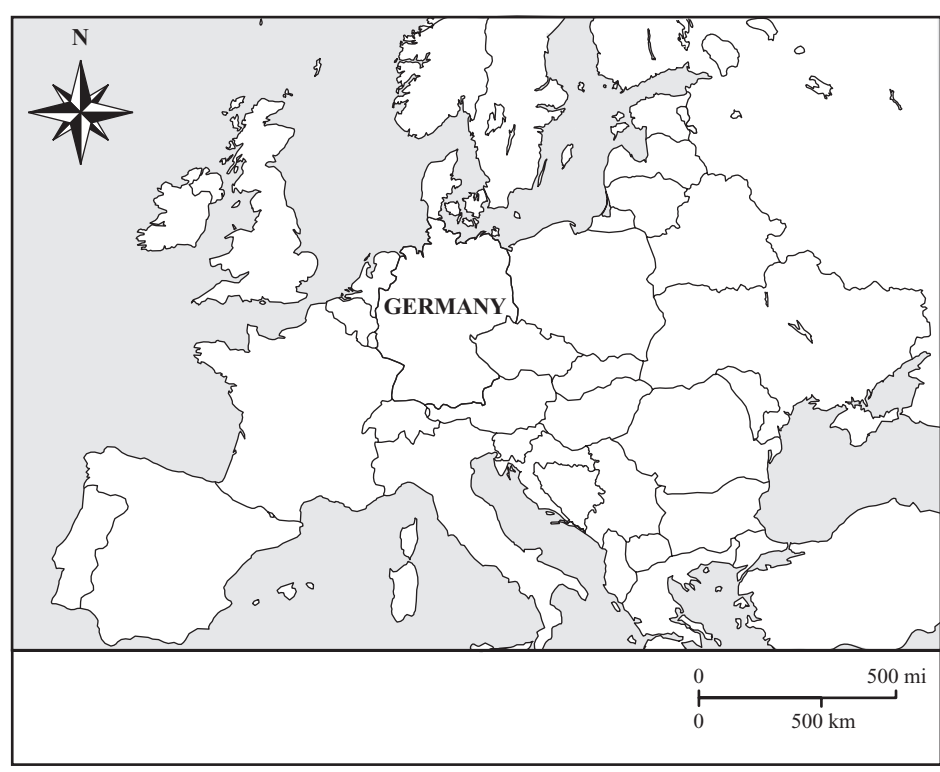

- Germany shares part of its eastern border with which country?
- A. Belgium
 - B. Denmark
 - C. Poland
 - D. Switzerland

- 6 The Peloponnesian War ended the Golden Age of which Greek city-state?
- A. Athens
 - B. Mycenae
 - C. Sparta
 - D. Troy

The maps that follow are associated with Australia.

First, you will answer three multiple-choice questions about Australia. Then you will answer two parts of an open-response question about its settlement patterns and economic development.

Australia: Physical Features Map

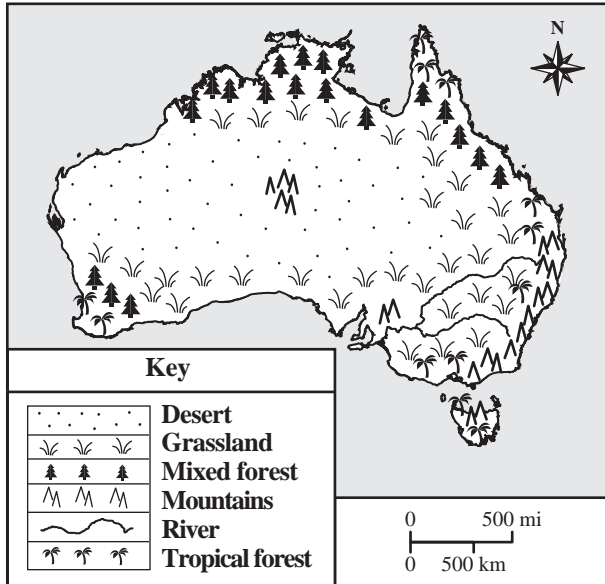

Australia: Industry Map

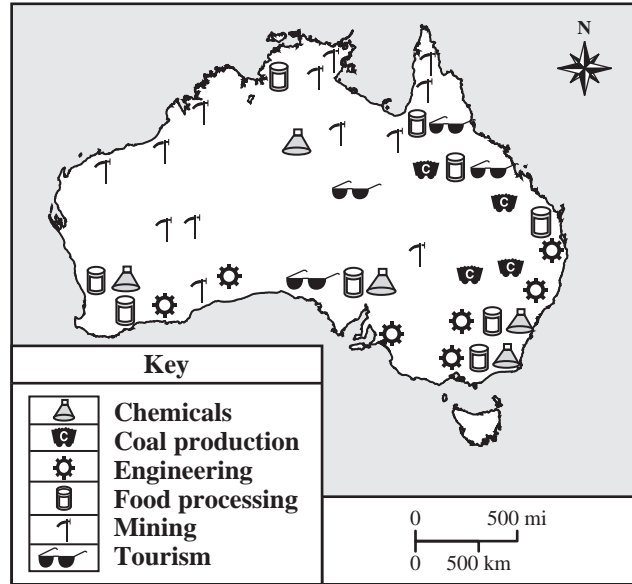

Australia: Climate Map

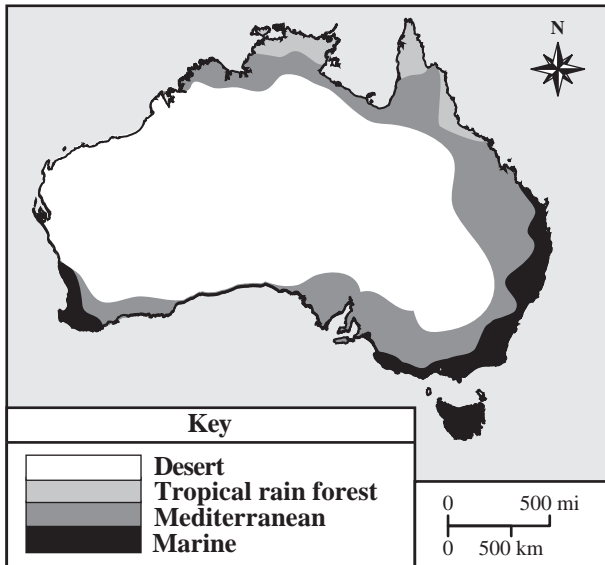

Australia: Major Cities Map

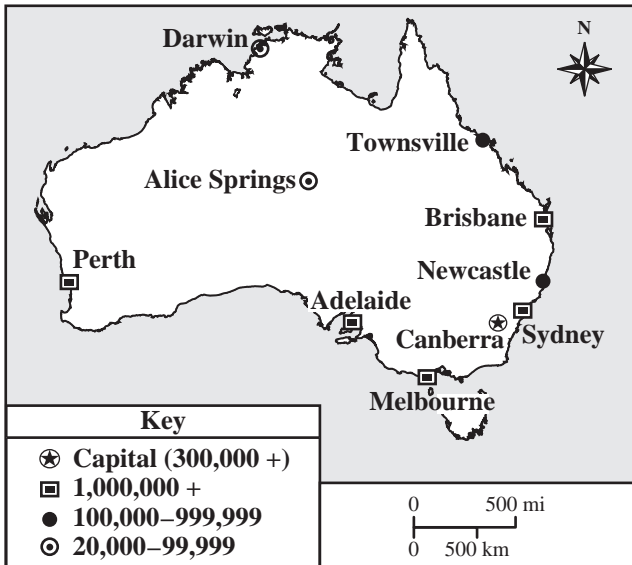

Mark your answers to questions 7 through 9 in the spaces provided in your Student Answer Booklet.

- 7 The map titled “Australia: Industry Map” is **most** useful for
- A. finding rivers in Australia.
 - B. studying the economy of Australia.
 - C. predicting the weather of Australia.
 - D. planning a camping trip in Australia.

- 8 The geography of western Australia **mostly** consists of
- A. tropical rain forests.
 - B. river valleys.
 - C. mountains.
 - D. deserts.

- 9 Which of the following describes the climate of Alice Springs?
- A. tropical
 - B. temperate
 - C. hot and arid
 - D. hot and semiarid

Write your answer to open-response question 10 in the space provided in your Student Answer Booklet.

- 10 Australia, which is both a country and a continent, has a number of geographic regions. The variety of Australia’s regions has affected its overall development.
- a. Describe where **most** of Australia’s population has settled and built major industries. Support your answer with information from the maps and your knowledge of Australian geography.
 - b. Explain how the physical features and climate of Australia have influenced its settlement patterns and economic development. Support your answer with information from the maps and your knowledge of Australian geography.

Mark your answers to questions 11 and 12 in the spaces provided in your Student Answer Booklet.

- 11 Which of the following physical features have had the most significant impact on Switzerland's settlement patterns?
- A. deserts
 - B. marshes
 - C. mountains
 - D. plains

- 12 Many archaeologists believe that early hunters and gatherers migrated from Asia to North America. This migration most likely occurred during a time when the climate changed and Earth entered
- A. a long ice age.
 - B. a severe drought.
 - C. an era of global warming.
 - D. an age of volcanic activity.

History and Social Science

SESSION 2

DIRECTIONS

This session contains five multiple-choice questions. Mark your answers to these questions in the spaces provided in your Student Answer Booklet.

13 Which of the following was the **main** reason the Greeks held the Olympic games?

- A. to encourage trade
- B. to establish colonies
- C. to spread Greek culture
- D. to honor the Greek god Zeus

14 Ancient Egypt was governed by a series of dynasties. When a dynasty collapsed, a new pharaoh emerged to found a new dynasty.

Which of the following is the **best** definition of the term *dynasty*?

- A. a ruling family
- B. a group of priests
- C. a group of nobles
- D. a large bureaucracy

15 According to Roman tradition, who were Romulus and Remus?

- A. Roman gods
- B. Roman emperors
- C. enemies of Rome
- D. founders of Rome

16 Some of the religious beliefs of an ancient people are listed in the box below.

- belief in one God
- belief in the Ten Commandments
- belief in individual worth
- belief in personal responsibility for behavior

This list **best** reflects the religious beliefs of which of the following ancient peoples?

- A. Egyptians
- B. Greeks
- C. Hebrews
- D. Phoenicians

17 A map of the world is shown below.

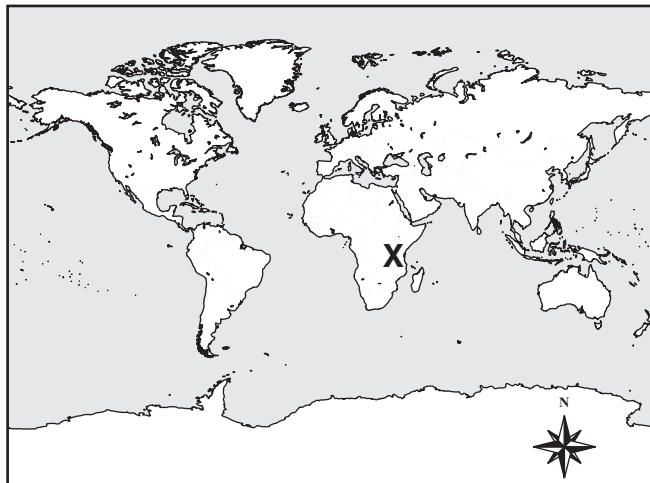

The **X** on the map marks the location of which physical feature?

- A. the Deccan Plateau
- B. the Great Rift Valley
- C. the Andes Mountains
- D. the Himalaya Mountains

Grade 7 History and Social Science
Spring 2007 Released Items:
Reporting Categories, Standards, and Correct Answers

Item No.	Page No.	Reporting Category	Learning Standard/ Concept and Skill	Correct Answer (MC)*
1	579	<i>World Geography 2: Europe, Africa, and South America</i>	6.A.3	A
2	579	<i>Ancient/Classical 2: Greece and Rome</i>	7.38	D
3	579	<i>World Geography 1: Asia (including Australia and Oceania)</i>	6.SEA0.2	D
4	580	<i>Ancient/Classical 2: Greece and Rome</i>	7.25	B
5	580	<i>World Geography 2: Europe, Africa, and South America</i>	6.E.2	C
6	581	<i>Ancient/Classical 2: Greece and Rome</i>	7.30	A
7	583	<i>World Geography 1: Asia (including Australia and Oceania)</i>	6.CS.1	B
8	583	<i>World Geography 1: Asia (including Australia and Oceania)</i>	6.SEA0.3	D
9	583	<i>World Geography 1: Asia (including Australia and Oceania)</i>	6.SEA0.3	C
10	583	<i>World Geography 1: Asia (including Australia and Oceania)</i>	6.SEA0.3	
11	584	<i>World Geography 2: Europe, Africa, and South America</i>	6.E.3	C
12	584	<i>Ancient/Classical 1: Human Origins and the Rise of Civilization</i>	7.1	A
13	585	<i>Ancient/Classical 2: Greece and Rome</i>	7.33	D
14	585	<i>Ancient/Classical 1: Human Origins and the Rise of Civilization</i>	7.14	A
15	585	<i>Ancient/Classical 2: Greece and Rome</i>	7.37	D
16	586	<i>Ancient/Classical 1: Human Origins and the Rise of Civilization</i>	7.21	C
17	586	<i>World Geography 2: Europe, Africa, and South America</i>	6.A.1	B

* Answers are provided here for multiple-choice items only. Sample responses and scoring guidelines for the open-response item, which is indicated by the shaded cell, will be posted to the Department's Web site later this year.

XXIV. U.S. History, High School

High School U.S. History Test

The spring 2007 high school MCAS U.S. History test was based on learning standards for U.S. History I and U.S. History II found on pages 65–80 of the Massachusetts *History and Social Science Curriculum Framework* (2003), and concepts and skills for grades 8–12, found on pages 49–50 in the *Framework*. This framework is available on the Department Web site at www.doe.mass.edu/frameworks/current.html.

The test items that appear on the following pages compose one-half of the common items that appeared on the high school U.S. History test.

In *Test Item Analysis Reports*, high school U.S. History test results are reported under four reporting categories:

- United States History I (to 1865)
- United States History II (to circa 1990)
- Civics and Government
- Economics

For detailed information about the distribution of high school test items by reporting category, please consult pages 4 and 6 of the *MCAS Guide to History and Social Science Assessments* (February 2007). This publication is available on the Department Web site at www.doe.mass.edu/mcas/2007/admin/hssguide.pdf.

Test Sessions and Content Overview

The 2007 high school MCAS U.S. History test included two separate test sessions. Each session included multiple-choice and open-response questions.

Reference Materials and Tools

The use of bilingual word-to-word dictionaries was allowed for current and former limited English proficient students only, during both U.S. History test sessions. No other reference materials were allowed.

Cross-Reference Information

The table at the conclusion of this chapter indicates each item’s reporting category as well as the learning standard or concept and skill it assesses. The coding for U.S. History learning standards appears in the table as it appears in the *Framework*. The codes containing the letters “CS” represent standards listed in the Concepts and Skills section of the *Framework* for grades 8–12.

U.S. History

SESSION 1

DIRECTIONS

This session contains fifteen multiple-choice questions and one open-response question. Mark your answers to these questions in the spaces provided in your Student Answer Booklet.

1 Why was the Bill of Rights added to the United States Constitution?

- A. to ensure rights of foreigners
- B. to ensure slaves' right to vote
- C. to protect the federal government from the states
- D. to protect the individual rights of citizens from government abuse

2 When people purchase shares of stock in the stock market, they are investing in

- A. corporations.
- B. labor unions.
- C. governments.
- D. political parties.

3 The excerpt below is from Frederick Douglass's "Independence Day" speech in 1852.

The rich inheritance of justice, liberty, prosperity and independence, bequeathed by your fathers is shared by you, not by me. The sunlight that brought life and healing to you has brought stripes and death to me. This Fourth of July is yours, not mine.

—Frederick Douglass,
"Independence Day" speech (1852)

In this speech, Frederick Douglass was speaking on behalf of which group?

- A. exiled American Indians
- B. deported American Jews
- C. oppressed Irish Americans
- D. enslaved African Americans

- 4 The table below shows the changes in the percentage of households owning specific items between 1940 and 1955.

Ownership of Automobiles and Household Appliances

Items Owned	Percentage of U.S. Households Owning Items	
	1940	1955
an automobile	50%	71%
a television	0%	76%
a refrigerator	44%	94%
a washing machine	56%	84%
a clothes dryer	0%	9%
a vacuum cleaner	38%	64%

Paul Boyer, *The American Nation* (1998)

According to the table, which of the following is one way that American households changed between 1940 and 1955?

- A. They had fewer children.
- B. They traveled less often.
- C. They enjoyed increased prosperity.
- D. They purchased fewer consumer goods.

- 5 Which of the following **best** explains why the United States Senate rejected American participation in the League of Nations after World War I?
- A. Senators thought league membership would cost too much money.
 - B. Senators thought the league would interfere in Latin American affairs.
 - C. Senators thought the league would require its members to reduce tariffs.
 - D. Senators thought league membership would undermine American sovereignty.

- 6 Which of the following is the **most** important responsibility of the Federal Reserve System?
- A. to set the minimum wage
 - B. to regulate gasoline prices
 - C. to regulate stock exchanges
 - D. to control the money supply

- 7 The graph below shows the number of farms in the United States in 1860 and 1910.

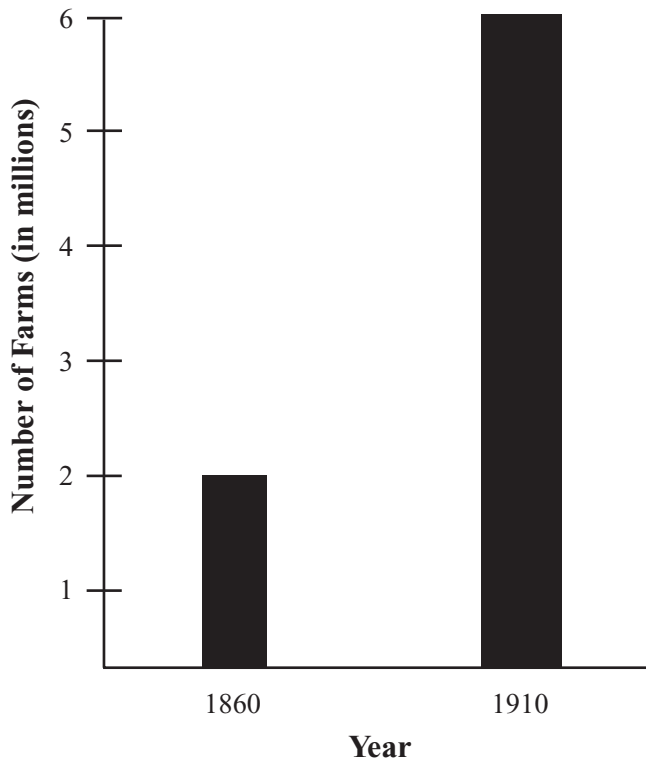

Paul Johnson, *A History of the American People*
(Harper Perennial: 1997)

How did the Homestead Act of 1862 contribute to the changes shown on the graph?

- A. The government provided land to settlers in the West.
- B. The government gave funds to railroad companies in the West.
- C. The government funded large-scale irrigation projects in the West.
- D. The government promised to buy cash crops from farmers in the West.

- 8 What was the most important result of the Hayes-Tilden agreement (Compromise of 1877) following the presidential election of 1876?

- A. the end of Reconstruction
- B. the passage of the Dawes Act
- C. the rise of multiple radical political parties
- D. the construction of the transcontinental railroad

- 9 The Supreme Court case *Marbury v. Madison* (1803) established which constitutional principle?

- A. due process
- B. judicial review
- C. implied powers
- D. equal protection

- 10 An oligarchy can **best** be described as a government that is ruled by

- A. a king.
- B. the people.
- C. a small elite.
- D. religious leaders.

In this section, you will consider Abraham Lincoln's Gettysburg Address.

First, you will answer three multiple-choice questions. Then you will answer two parts of an open-response question about the Gettysburg Address.

The Gettysburg Address (1863)

Four score and seven years ago our fathers brought forth on this continent, a new nation, conceived in Liberty, and dedicated to the proposition that all men are created equal.

Now we are engaged in a great civil war, testing whether that nation, or any nation so conceived and so dedicated, can long endure. We are met on a great battle-field of that war. We have come to dedicate a portion of that field, as a final resting place for those who here gave their lives that that nation might live. It is altogether fitting and proper that we should do this.

But, in a larger sense, we can not dedicate—we can not consecrate—we can not hallow—this ground. The brave men, living and dead, who struggled here, have consecrated it, far above our poor power to add or detract. The world will little note, nor long remember what we say here, but it can never forget what they did here. It is for us the living, rather, to be dedicated here to the unfinished work which they who fought here have thus far so nobly advanced. It is rather for us to be here dedicated to the great task remaining before us—that from these honored dead we take increased devotion to that cause for which they gave the last full measure of devotion—that we here highly resolve that these dead shall not have died in vain—that this nation, under God, shall have a new birth of freedom—and that government of the people, by the people, for the people, shall not perish from the earth.

Mark your answers to questions 11 through 13 in the spaces provided in your Student Answer Booklet.

- 11 Why did President Lincoln travel to Gettysburg to deliver an address in 1863?
- A. to establish headquarters for the Union army
 - B. to dedicate a cemetery for deceased soldiers
 - C. to honor families of confederate volunteers
 - D. to raise money for the abolitionist cause
- 12 The Battle of Gettysburg was an important event in the Civil War **mainly** for which of the following reasons?
- A. Great Britain refused to support the Confederacy after the Union victory.
 - B. The Union victory was the first time the North used African American soldiers in combat.
 - C. The Confederacy never attempted another major invasion of the North after the Union victory.
 - D. Congress immediately ratified the Thirteenth Amendment upon hearing of the Union victory.
- 13 To which of the following events was President Lincoln referring when he stated, “Four score and seven years ago our fathers brought forth on this continent, a new nation . . .”?
- A. the Boston Tea Party
 - B. the Battle of Yorktown
 - C. the signing of the Declaration of Independence
 - D. the ratifying of the Constitution of the United States

Write your answer to open-response question 14 in the space provided in your Student Answer Booklet.

- 14** In the Gettysburg Address, President Lincoln refers to the nation as having “a new birth of freedom.”
- Explain what President Lincoln meant when he called for “a new birth of freedom.” You may support your answer with information from the Gettysburg Address and your knowledge of American history.
 - Explain why Lincoln believed a unified nation should be preserved. You may support your answer with information from the Gettysburg Address and your knowledge of American history.

Mark your answers to questions 15 and 16 in the spaces provided in your Student Answer Booklet.

- 15 The excerpt below is from Richard Nixon’s “Silent Majority” speech.

Let historians not record that when America was the most powerful nation in the world we passed on the other side of the road and allowed the last hopes for peace and freedom of millions of people to be suffocated by the forces of totalitarianism.

And so tonight—to you, the great silent majority of my fellow Americans—I ask for your support.

—President Richard Nixon,
“Silent Majority” speech (November 3, 1969)

In his speech, President Nixon asked the American people to support his position on which of the following issues?

- A. the Vietnam War
- B. the War Powers Act
- C. the Watergate scandal
- D. the Middle East peace process

- 16 The quotation below is from a speech given by Senator Albert Beveridge in 1898.

Hawaii is ours; [Puerto] Rico is to be ours; at the prayer of her people Cuba finally will be ours; in the islands of the East . . . the flag of a liberal government is to float over the Philippines . . . The Opposition tells us that we ought not to govern a people without their consent. I answer the rule . . . that all just government derives its authority from the consent of the governed, applies only to those who are capable of self-government.

—Senator Albert Beveridge,
“The March of the Flag” speech (1898)

Which policy was Senator Beveridge advocating in this statement?

- A. containment
- B. disarmament
- C. imperialism
- D. isolationism

U.S. History

SESSION 2

DIRECTIONS

This session contains seven multiple-choice questions. Mark your answers to these questions in the spaces provided in your Student Answer Booklet.

- 17 The map below shows the continental United States with four canals labeled A, B, C, and D.

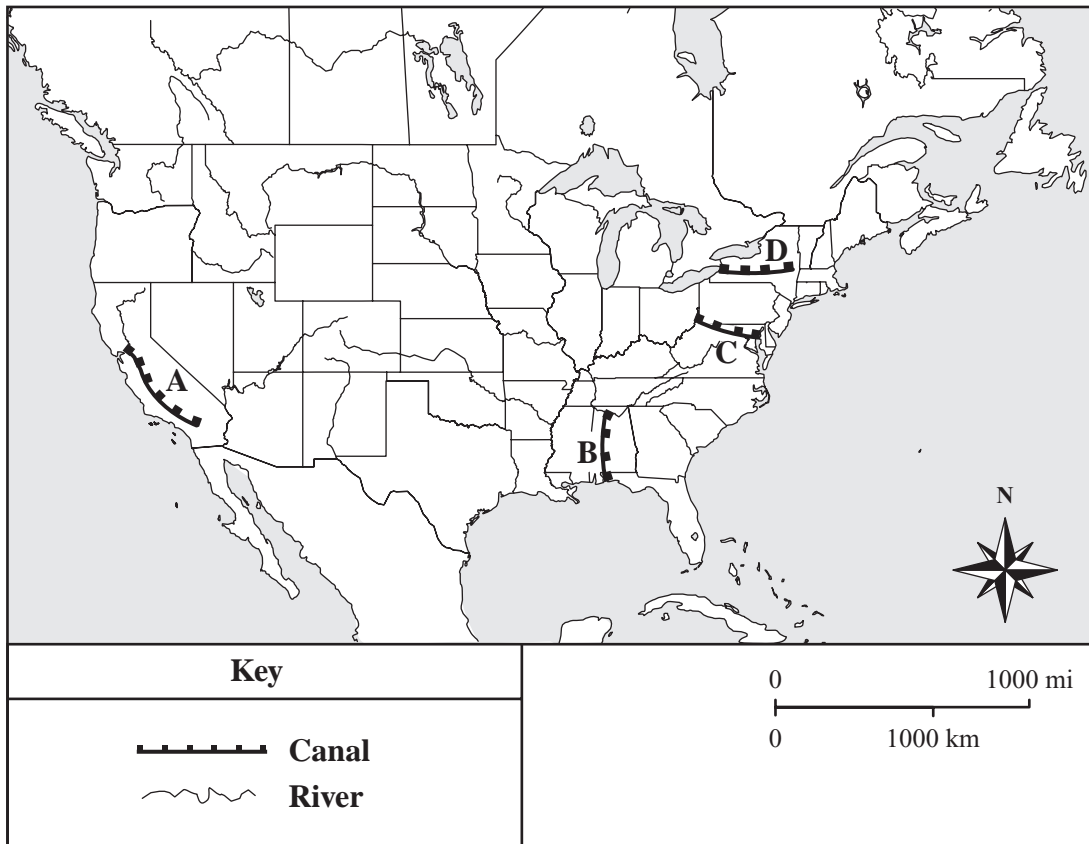

Which letter marks the location of the Erie Canal?

- A. A
- B. B
- C. C
- D. D

- 18 In 1937, after four years of steady growth, economic activity in the United States declined by 27 percent. Which of the following terms **best** describes this decline in the economy?
- A. affluence
 - B. inflation
 - C. recession
 - D. recovery

- 19 The poster shown below is from World War II.



J. Howard Miller, "We Can Do It!" (ca. 1942)
© J. Howard Miller/CORBIS

- This World War II poster was made to encourage women to
- A. buy war bonds.
 - B. enlist in the military.
 - C. plant victory gardens.
 - D. work in defense industries.

- 20 Which of the following issues was central to the Nullification Crisis of 1832–1833?
- A. due process
 - B. laissez faire
 - C. states' rights
 - D. women's rights
- 21 Which of the following is a responsibility of the Massachusetts Supreme Judicial Court?
- A. to enforce laws
 - B. to write legislation
 - C. to hear cases on appeal
 - D. to propose new amendments
- 22 Which of the following is the **main** reason President Harry Truman gave for ordering an atomic bomb to be dropped on Hiroshima?
- A. to show the world the horror of atomic bombs
 - B. to avoid large American casualties in an invasion of Japan
 - C. to persuade communist China that it should stay out of the war
 - D. to demonstrate to Germany that the United States had an atomic bomb

- 23 The excerpt below is from George Washington's Farewell Address in 1796.

It [party conflict] serves always to distract the public councils and enfeeble the public administration. It agitates the community with ill-founded jealousies and false alarms; kindles the animosity [hatred] of one part against another; foment[s] [provokes] occasionally riot and insurrection.

—George Washington,
Farewell Address (1796)

Which of the following statements **best** summarizes George Washington's view of political parties?

- A. They were sources of corruption.
- B. They were controlled by social elites.
- C. They were sources of division in the country.
- D. They were prone to influence by foreign powers.

High School U.S. History
Spring 2007 Released Items:
Reporting Categories, Standards, and Correct Answers

Item No.	Page No.	Reporting Category	Learning Standard/ Concept and Skill	Correct Answer (MC)*
1	591	<i>Civics and Government</i>	USI.9	D
2	591	<i>Economics</i>	CS.15	A
3	591	<i>United States History I (to 1865)</i>	USI.31	D
4	592	<i>United States History II (to circa 1990)</i>	USII.22	C
5	592	<i>United States History II (to circa 1990)</i>	USII.7	D
6	592	<i>Economics</i>	CS.26	D
7	593	<i>United States History II (to circa 1990)</i>	USII.4	A
8	593	<i>United States History I (to 1865)</i>	USI.41	A
9	593	<i>Civics and Government</i>	USI.25	B
10	593	<i>Civics and Government</i>	USI.12	C
11	595	<i>United States History I (to 1865)</i>	USI.38	B
12	595	<i>United States History I (to 1865)</i>	USI.39	C
13	595	<i>United States History I (to 1865)</i>	USI.38	C
14	596	<i>United States History I (to 1865)</i>	USI.38	
15	597	<i>United States History II (to circa 1990)</i>	USII.28	A
16	597	<i>United States History II (to circa 1990)</i>	USII.6	C
17	598	<i>United States History I (to 1865)</i>	USI.27	D
18	599	<i>Economics</i>	CS.16	C
19	599	<i>United States History II (to circa 1990)</i>	USII.17	D
20	600	<i>United States History I (to 1865)</i>	USI.36	C
21	600	<i>Civics and Government</i>	USI.17	C
22	600	<i>United States History II (to circa 1990)</i>	USII.16	B
23	600	<i>United States History I (to 1865)</i>	USI.20	C

* Answers are provided here for multiple-choice items only. Sample responses and scoring guidelines for the open-response item, which is indicated by the shaded cell, will be posted to the Department's Web site later this year.

